

INSTRUCTION/MANUAL
OSCILLOSCOPE
COS5020
MODEL COS5021

For Service Manuals Contact
MAURITRON TECHNICAL SERVICES
8 Cherry Tree Rd, Chinnor
Oxon OX9 4QY
Tel:- 01844-351694 Fax:- 01844-352554
Email:- enquiries@mauritron.co.uk

1998



KIKUSUI
ELECTRONICS CORP.

TABLE OF CONTENTS

| | <u>PAGE</u> |
|--|-------------|
| 1. GENERAL | 1 |
| 1.1 Description | 1 |
| 1.2 Features | 1 |
| 2. SPECIFICATIONS | 3 |
| 3. PRECAUTIONS BEFORE OPERATING THE OSCILLOSCOPE | 10 |
| 3.1 Unpacking the Oscilloscope | 10 |
| 3.2 Checking the Line Voltage | 10 |
| 3.3 Environments | 10 |
| 3.4 CRT Intensity | 11 |
| 3.5 Withstanding Voltages of Input Terminals | 11 |
| 4. OPERATION METHOD | 12 |
| 4.1 Explanation of Front Panel | 12 |
| 4.2 Explanation of Rear Panel | 20 |
| 4.3 Basic Operation | 25 |
| 4.4 Dual-channel Operation | 27 |
| 4.5 ADD Operation | 28 |
| 4.6 X-Y Operation and EXT HOR Operation | 28 |
| 4.7 Triggering | 30 |
| 4.8 Single-sweep Operation | 35 |
| 4.9 Sweep Magnification | 36 |
| 4.10 Waveform Magnification with Delayed Sweep | 37 |
| (COS5021 only) | |
| 4.11 Calibration of Probe | 41 |

| | <u>PAGE</u> |
|--|-------------|
| 5. CIRCUIT DESCRIPTION | 42 |
| 5.1 General | 42 |
| 5.2 Preamplifiers | 45 |
| 5.3 Vertical Switching Circuit | 48 |
| 5.4 Vertical Output Amplifier | 52 |
| 5.5 Trigger Generator | 53 |
| 5.6 A and B Sweep Generators | 55 |
| 5.7 Horizontal Switching Circuit | 59 |
| 5.8 Horizontal Output Amplifier | 60 |
| 5.9 Z-axis Amplifier | 61 |
| 5.10 CRT Control circuit | 61 |
| 5.11 H.V Regulator (High Voltage Generator) | 62 |
| 5.12 Power Supply Circuit | 62 |
| 5.13 Calibrator Circuit | 63 |
| 6. CALIBRATION | 64 |
| 6.1 General | 64 |
| 6.2 Removing the Case | 64 |
| 6.3 Check and Adjustment of DC Supply Voltages | 65 |
| 6.4 Adjustment of CRT Circuits | 66 |
| 6.5 Adjustment of Vertical Axis | 67 |
| 6.6 Adjustment of Trigger Circuit | 72 |
| 6.7 Adjustment of Time Base | 73 |
| 6.8 Adjustment of Horizontal Axis (X-axis) | 75 |

For Service Manuals Contact
MAURITRON TECHNICAL SERVICES
 8 Cherry Tree Rd, Chinnor
 Oxon OX9 4QY
 Tel: 01844-351694 Fax: 01844-352554
 Email: enquiries@mauritron.co.uk

| | | |
|--|--------------|--------|
| * BLOCK DIAGRAM | | |
| * CIRCUIT SCHEMATICS | | |
| MODELS COS5020 AND COS5021 | | |
| VERTICAL AMPLIFIER | | ① |
| TRIG & SWEEP GENERATOR | | ② |
| CRT CIRCUIT & POWER SUPPLY | | ③ |
| * PARTS LOCATIONS | | |
| Vert Amp & Power Supply A1 | | [1] |
| Sweep & H.V A2 | | [2] |
| * SEMICONDUCTOR LEAD CONFIGURATION | | |
| * REPLACEABLE PARTS | | |
| FOR MODEL COS5020 | 1/13 ~ 13/13 | |
| FOR MODEL COS5021 | 1/14 ~ 14/14 | |
| * MECHANICAL ASSEMBLY DRAWINGS | | |
| FRONT PANEL ASSEMBLY (COS5021/COS5041) | | 316097 |
| FRONT PANEL ASSEMBLY (COS5020/COS5040) | | 316098 |
| FRONT FRAME ASSEMBLY | | 316099 |
| REAR PLATE ASSEMBLY | | 316100 |
| CRT ASSEMBLY | | 316102 |
| CIRCUIT BOARD ASSEMBLY (VERTICAL) | | 316104 |
| CIRCUIT BOARD ASSEMBLY (TIME-BASE) | | 316106 |
| CIRCUIT BOARDS INSTALLATION | | 316107 |
| COVER & HANDLE ASSEMBLY | | 316109 |
| BOTTOM PLATE ASSEMBLY | | 316110 |

1. GENERAL

1.1 Description

Kikusui Model COS5020/5021 Oscilloscope is a dual-channel oscilloscope with frequency bandwidth DC - 20 MHz (-3 dB), maximum sensitivity 1 mV/DIV, and maximum sweep time 20 nsec/DIV. Model 5021 has a sweep magnification feature with B sweep. The oscilloscope employs a 6-inch rectangular type cathode-ray tube with red internal graticule.

The oscilloscope is sturdy, easy to operate, and exhibits a high operation reliability. It is incorporated with the various convenient features and excellent functions, making itself an ideal instrument for diversified types of research and development work of electronic devices and equipment it can also be efficiently used for production lines and for maintenance and service.

1.2 Features

(1) Compact, light, but sturdy:

The oscilloscope is made of aluminium diecast and it is compact, light, but sturdy.

(2) Excellent operability:

Light torque types of lever switches and pushbutton switches are used. These and other controls are laid out in the most rational locations taking purposes and frequencies of their uses into consideration, thereby attaining an excellent operability.

(3) High intensity CRT with high acceleration voltage:

The CRT is a high beam transmission, high intensity type with a high acceleration voltage of 2.2 kV. It displays clearly readable traces even at high sweep speeds.

For Service Manuals Contact
MAURITRON TECHNICAL SERVICES
8 Cherry Tree Rd, Chinnor
Oxon OX9 4QY
Tel:- 01844-351694 Fax:- 01844-352554
Email:- enquiries@mauritron.co.uk

(4) High stability with less drift:

The oscilloscope employs a newly-developed temperature compensation circuit, thereby greatly reducing drift of base lines and DC balance disturbance caused by temperature change.

(5) A trigger level lock function which makes triggering adjustment procedure unnecessary:

A new trigger level lock circuit is incorporated. This circuit eliminates the requirement of troublesome triggering adjustment procedure not only for display of regular signals but also for that of video signals and large duty cycle ratio signals.

(6) TV sync triggering:

The oscilloscope has a sync separator circuit and triggering for TV V signal and TV H signal can be automatically switched being linked to the TIME/DIV switch.

(7) Linear focus:

Once the beam focus is adjusted to the optimum position, it is automatically maintained irrespective of intensity change, even for such waveforms with brightness variation as those displayed in the A INTEN mode.

For Service Manuals Contact
MAURITRON TECHNICAL SERVICES
8 Cherry Tree Rd, Chinnor
Oxon OX9 4QY
Tel:- 01844-351694 Fax:- 01844-352554
Email:- enquiries@mauritron.co.uk

2. SPECIFICATIONS

Vertical axes

| Item | Specification | Remarks |
|------------------------------|--|---|
| Sensitivity | NORM: 5 mV - 5 V/DIV ×5 MAG: 1 mV - 1 V/DIV | 1-2-5 sequence, 10 ranges |
| Sensitivity accuracy | NORM: ±3% or better ×5 MAG: ±5% or better | 10 to 35°C (50 to 95°F), 1 kHz, at 4 or 5 DIV |
| Vernier vertical sensitivity | To 1/2.5 or less of panel-indicated value | |
| Frequency bandwidth | NORM: DC - 20 MHz, within -3 dB ×5 MAG: DC - 15 MHz, within -3 dB AC coupling: Low limit frequency 10 Hz | With reference to 50 kHz, 8 DIV |
| Rise time | NORM: Approx. 17.5 nsec ×5 MAG: Approx. 23 nsec | |
| Input impedance | 1 MΩ ±2%, 25 pF ±2 pF | |
| Square wave characteristics | Overshoot: Not greater than 3% Other distortions: Not greater than 2% (At 10 mV/DIV range) | Other ranges: 3% added to the left values. 10 to 35°C (50 to 95°F) |
| DC balance shift | NORM: ±0.5 DIV ×5 MAG: ±2.0 DIV | |
| Linearity | ±0.1 DIV or less of amplitude change when waveform of 2 DIV at graticule center is moved vertically. | |
| Display modes | CH1: CH1 single channel | When CH1 POSITION knob is pulled out (CHOP ONLY position), the two traces are displayed in the CHOP mode at all ranges. |
| | CH2: CH2 single channel | |
| | DUAL: CHOP: 0.5 sec - 1 msec/DIV ALT: 0.5 msec - 0.2 μsec/DIV | |

| Item | Specification | Remarks |
|---------------------------------|---|--|
| | ADD: CH1 + CH2 algebraic addition | |
| Chopping repetition frequency | Approx. 250 kHz | |
| Input coupling | AC/GND/DC | |
| Maximum allowable input voltage | 400 V (DC + AC peak) | AC: 1 kHz or lower |
| Common mode rejection ratio | 50:1 or better at 50 kHz, sinusoidal wave | When sensitivities of CH1 and CH2 are set equal |
| Isolation between channels | At least 1000:1 at 50 kHz At least 30:1 at 20 MHz | At 5 mV/DIV range |
| CH1 signal output | Approx. 100 mV/DIV when open; approx. 50 mV/DIV when 50-ohm termination | |
| CH2 INV BAL | Balanced point variation, 1 DIV or less | PULL CH2 POSITION (Reference at center graticule) |

Triggering

| Item | Specification | Remarks |
|-------------------|---|--|
| Triggering source | CH1, CH2, LINE, and EXT (CH1 and CH2 can be selected only when the vertical mode is DUAL or ADD. In other cases, triggering source is automatically selected by the VERT MODE switch.) | For Service Manuals Contact MAURITRON TECHNICAL SERVICES 8 Cherry Tree Rd, Chinnor Oxon OX9 4QY Tel:- 01844-351694 Fax:- 01844-352554 Email:- enquiries@mauritron.co.uk |
| Coupling | AC, HF REJ, TV, DC | |
| Polarity | + or - | |
| | | |

| Item | Specification | Remarks |
|---------------------------------|---|---|
| Sensitivity | DC - 10 MHz: 0.5 DIV (0.1 V) DC - 20 MHz: 1.5 DIV (0.2 V) Video signal: 2.0 DIV (0.2 V) AC coupling: Attenuate signal components of lower than 10 Hz HF REJ: Attenuate signal components of higher than 50 kHz | The values enclosed in the parentheses are the input sensitivities when in the EXT triggering mode. |
| Triggering modes | AUTO: Sweeps run in the free mode when no triggering input signal is applied. | Satisfies the sensitivity specification for signal repetition frequency of 50 Hz or over. |
| | NORM: When no triggering signal is applied, the trace is in the READY state and not displayed. SINGLE: One-shot sweep with triggering signal. Can be reset to the READY state by means of RESET switch. The READY lamp (LED) turns on when in the READY state or in the sweep operation. | |
| LEVEL LOCK | Satisfies the value of the above trigger sensitivity plus 0.5 DIV (0.05 V) for signal of duty cycle 20:80 and repetition frequency 50 Hz - 20 MHz. | |
| EXT triggering signal input | EXT HOR input terminal is used in common. | |
| Input impedance | 1 M Ω \pm 2%, approx. 25 pF | |
| Maximum allowable input voltage | 100 V (DC + AC peak) | AC frequency not higher than 1 kHz |
| B triggering signal | The A triggering signal of main sweep is used as the B triggering signal. | <u>Model COS5021 only</u> |

Horizontal axis

| Item | Specification | Remarks |
|-------------------------------|---|--|
| Horizontal axis display | A, A INT, B, B TRIG'D | COS5021 only |
| A sweep (main sweep) | | |
| Sweep time | 0.2 μ sec - 0.5 sec/DIV | 1-2-5 sequence, 20 ranges |
| Sweep time accuracy | $\pm 3\%$ | 10 to 35°C (50 to 95°F) |
| Vernier sweep time control | To 1/2.5 or slower of panel-indicated value | |
| Holdoff time | Continuously variable to 2 times or over of sweep length (time) at 0.2 μ sec/DIV - 1 msec/DIV ranges | |
| B sweep | | COS5021 only. |
| Delay system | Continuous delay and triggered delay | Triggered by A triggering signal |
| Sweep time | NORM: 0.2 μ sec/DIV - 0.5 msec/DIV $\times 10$ MAG: 20 nsec/DIV - 50 μ sec/DIV | |
| Sweep time accuracy | NORM: $\pm 3\%$ | 10 to 30°C (50 to 95°F) |
| Delay time | 2 μ sec - 5 sec/DIV | |
| Delay time accuracy | $\pm 4\%$ of the value read on CRT | |
| Delay jitter | 1/10,000 or less $\frac{\text{B sweep time}}{\text{A sweep time}} \times \frac{\text{jitter width}}{10 \text{ DIV}}$ | Jitter width 0.5 DIV or less at A: 1 msec/DIV B: 1 μ sec/DIV |
| Sweep magnification | 10 times (maximum sweep time 20 nsec/DIV) | |
| Magnified sweep time accuracy | 0.1 μ sec/DIV - 0.5 sec/DIV ranges: $\pm 5\%$ 0.2 μ sec/DIV - 0.5 μ sec/DIV ranges: $\pm 8\%$ | 10 to 35°C (50 to 95°F) |
| Linearity | NORM: $\pm 3\%$ $\times 10$ MAG: $\pm 5\%$ ($\pm 8\%$ for 0.2 μ sec and 0.5 μ sec/DIV) | |

| Item | Specification | Remarks |
|--|--|---|
| Position shift caused by sweep magnification | Within 1 DIV at CRT screen center | |
| X-Y mode | X-axis: CH1 input signal Y-axis: CH2 input signal | |
| Sensitivity | Same as CH1 vertical axis | |
| Sensitivity accuracy | NORM: $\pm 4\%$ $\times 5$ MAG: $\pm 6\%$ | 10 to 35°C (50 to 95°F), 1 kHz, at 4 or 5 DIV |
| Frequency bandwidth | DC - 1 MHz (-3 dB) | |
| X-Y phase difference | Not greater than 3° at DC - 50 kHz | |
| EXT HOR mode | Trace swept by an external horizontal signal applied to the EXT TRIG IN terminal. Vertical axis modes are CH1, CH2, DUAL and ADD modes in the CHOP mode. | |
| Sensitivity | Approx. 0.1 V/DIV | |
| Frequency bandwidth | DC - 1 MHz (-3 dB) | |
| Phase difference between vertical axis | Within 3° (at DC - 50 kHz) | |

Z axis

| Item | Specification | Remarks |
|-------------------------|---|------------------------------------|
| Sensitivity | 3 Vp-p (Trace becomes brighter with negative input.) | |
| Frequency bandwidth | DC - 5 MHz | |
| Input resistance | Approx. 5 k Ω | |
| Allowable input voltage | 50 V (DC + AC peak) | AC frequency not higher than 1 kHz |

Calibration voltage

| Item | Specification | Remarks |
|-------------------|-------------------------------|---------|
| Waveform | Positive-going square wave | |
| Frequency | 1 kHz \pm 20% | |
| Duty ratio | Within 45:55 | |
| Output voltage | 2 V _{p-p} , \pm 2% | |
| Output resistance | Approx. 2 k Ω | |

CRT

| Item | Specification | Remarks |
|-----------------------|--|--------------------------|
| Type | 6-inch rectangular type, internal graticule | |
| Phosphor | P31 | |
| Acceleration voltage | Approx. 2.2 kV | |
| Effective screen size | 8 \times 10 DIV | 1 DIV = 10 mm (0.39 in.) |
| Graticule | Internal graticule; continuously adjustable illumination | |

Line power requirements

Voltage: 100 V, 115 V, 215 V, 230 V; with \pm 10% allowance.

Selectable by connector change

Frequency: 50 Hz or 60 Hz

Power consumption: Approx. 35 VA

For Service Manuals Contact
MAURITRON TECHNICAL SERVICES
 8 Cherry Tree Rd, Chinnor
 Oxon OX9 4QY
 Tel: 01844-351694 Fax: 01844-352554
 Email: enquiries@mauritron.co.uk

Mechanical specifications

Mainframe dimensions: 280 W \times 150 H \times 370 D mm
 (11.02 W \times 5.91 H \times 14.57 D in.)

Maximum dimensions: 285 W \times 175 H \times 440 D mm
 (11.22 W \times 6.89 H \times 17.32 D in.)

Weight: Approx. 7.0 kg (15.4 lbs)

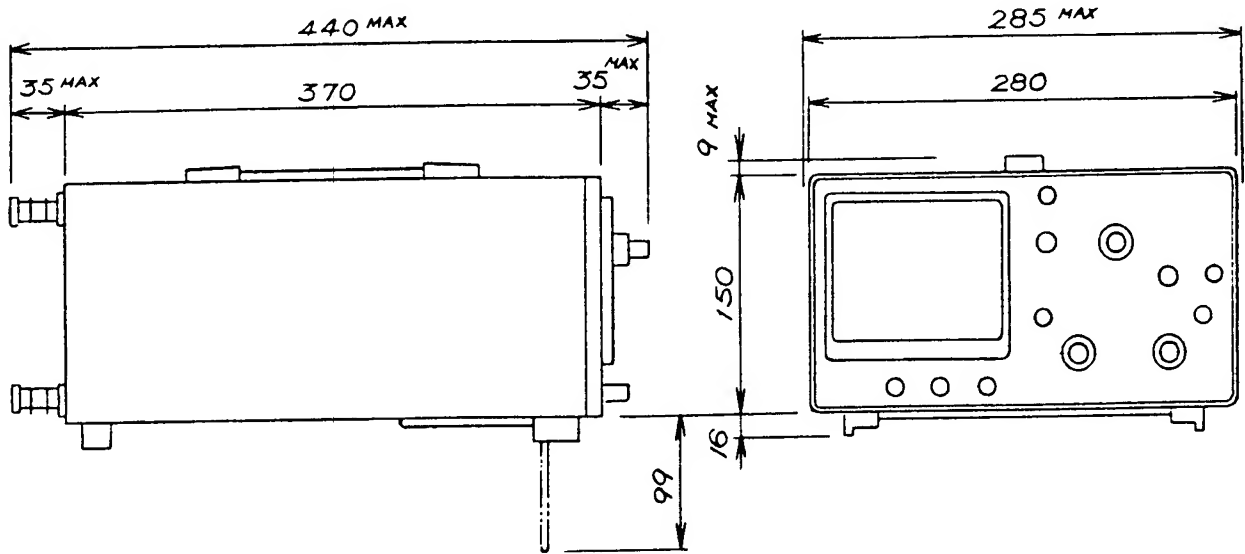

Operating environment

To satisfy specifications: 5 to 35°C (41 to 95°F), 85% RH

Maximum operating ranges: 0 to 40°C (32 to 104°F), 90% RH

Accessories

| | | |
|--------------------------------------|-------------------|---|
| PO60-S probes (10:1, 1:1. 1.5 m) ... | (89-03-0300) | 2 |
| 942A terminal adaptors | (W4-986-011) | 2 |
| Power cord | | 1 |
| Instruction manual | | 1 |

o Specifications and contents on this manual are subject to change without notice.

For Service Manuals Contact
MAURITRON TECHNICAL SERVICES
 8 Cherry Tree Rd, Chinnor
 Oxon OX9 4QY
 Tel:- 01844-351694 Fax:- 01844-352554
 Email:- enquiries@mauritron.co.uk

3. PRECAUTIONS BEFORE OPERATING THE OSCILLOSCOPE

3.1 Unpacking the Oscilloscope

The oscilloscope is shipped from the factory after being fully inspected and tested. Upon receipt of the instrument, immediately unpack and inspect it for any damage which might have been sustained when in transportation. If any sign of damage is found, immediately notify the bearer and/or the dealer.

3.2 Checking the Line Voltage

The oscilloscope can operate on any one of the line voltages shown in the below table, by inserting the line voltage selector plug in the corresponding position on the rear panel. Before connecting the power plug to an AC line outlet, be sure to check that the voltage selector plug is set in the correct position corresponding to the line voltage. Note the oscilloscope may not properly operate or may be damaged if it is connected to a wrong voltage AC line.

When line voltages are changed, replace fuses also as required.

| Selector plug position | Nominal voltage | Voltage tolerance | Fuse |
|------------------------|-----------------|-------------------|-------|
| A | 100 V | 90 - 110 V | 0.5 A |
| B | 115 V | 104 - 126 V | |
| C | 215 V | 194 - 236 V | 0.3 A |
| D | 230 V | 207 - 253 V | |

3.3 Environments

The normal ambient temperature range of this instrument is 0 to 40°C (32 to 104°F). Operation of the instrument outside of this temperature range may cause damage to the circuits.

Do not use the instrument in a place where strong magnetic or electric field exists. Such fields may disturb the measurement.

3.4 CRT Intensity

In order to prevent permanent damage to the CRT phosphor, do not make the CRT trace excessively bright or leave the spot stationary for an unreasonably long time.

3.5 Withstanding Voltages of Input Terminals

The withstanding voltages of the instrument input terminals and probe input terminals are as shown in the following table. Do not apply voltages higher than these limits.

| Input terminal | Maximum allowable input voltage |
|------------------|---------------------------------|
| CH1, CH2, inputs | 400 V (DC + AC peak) |
| EXT TRIG input | 100 V (DC + AC peak) |
| Probe inputs | 600 V (DC + AC peak) |
| Z AXIS input | 50 V (DC + AC peak) |

Note: AC frequency not higher than 1 kHz.

For Service Manuals Contact
MAURITRON TECHNICAL SERVICES
8 Cherry Tree Rd, Chinnor
Oxon OX9 4QY
Tel: 01844-351694 Fax: 01844-352554
Email: enquiries@mauritron.co.uk

4. OPERATION METHOD

4.1 Explanation of Front Panel (See Figures 4-1 and 4-2.)

o CRT circuits:

- POWER ③ Main power switch of the instrument.
When this switch is turned on, the
LED ② above the switch is also
turned on.
- INTEN ④ Controls the brightness of the spot
or trace
- B INTEN ⑤ Semi-fixed potentiometer for adjusting
(COS5021 only) trace intensity when in B sweep mode.
- FOCUS ⑥ For focusing the trace to the sharpest
image.
- ILLUM ⑧ Graticule illumination adjustment.
- TRACE ROTATION ⑦ Semi-fixed potentiometer for aligning
the horizontal trace in parallel with
graticule lines.
- Bezel ③⑤ For installing a camera mount in
one-touch operation.
- Filter ③⑥ Blue filter for ease of waveform
viewing. Can be removed in one-
touch operation.

o Vertical axis:

- CH1 (X) input ⑪ Vertical input terminal of CH1.
During X-Y operation, this becomes
X-axis (abscissa) input terminal.

CH2 (Y) input (18) Vertical input terminal of CH2.
 During X-Y operation, this becomes Y-axis (ordinate) input terminal.

AC-GND-DC (10) (19) Switch for selecting connection mode between input signal and vertical amplifier.

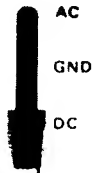

AC: AC coupling
 GND: Vertical amplifier input is grounded and input terminals are disconnected.
 DC: DC coupling

VOLTS/DIV (12) (16) Select the vertical axis sensitivity, from 5 mV/DIV to 5 V/DIV with 10 ranges.

VARIABLE (13) (17)

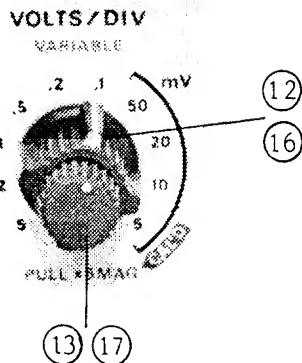

Fine adjustment of sensitivity, with a factor of 1/2.5 or higher of the panel-indicated value. At the CAL'D position, sensitivity is calibrated to the panel-indicated value. When this knob is pulled out (x5 MAG state), the amplifier sensitivity is multiplied by 5 times.

POSITION (9) (20) Vertical positioning control of trace or spot.

VERT MODE (14) Selects operation modes of CH1 and CH2 amplifiers. Also selects internal triggering source signal.

CH1: The oscilloscope operates as a single-channel instrument with CH1 alone. The CH1 input signal is used as the internal triggering source signal.

For Service Manuals Contact
MAURITRON TECHNICAL SERVICES
 8 Cherry Tree Rd, Chinnor
 Oxon OX9 4QY
 Tel:- 01844-351694 Fax:- 01844-352554
 Email:- enquiries@mauritron.co.uk

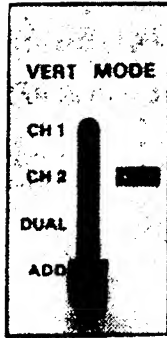

CH2: The oscilloscope operates as a single-channel instrument with CH2 alone. The CH2 signal is used as the internal triggering source signal.

DUAL: The oscilloscope operates as a dual-channel instrument with both CH1 and CH2. The internal triggering source signal is selected by SOURCE switch (26).

ADD: The oscilloscope displays the algebraic sum (CH1 + CH2) or difference (CH1 - CH2) of the two signals. The pulled out state of CH2 POSITION knob (20) provides the difference (CH1 - CH2). The internal triggering source signal is selected by SOURCE switch (26).

o Triggering

EXT TRIG (EXT HOR) .. (23)
input terminal



This terminal is used in common for external triggering signal and external horizontal signal. To use this terminal, set SOURCE switch (26) to the EXT position.

SOURCE (26)

Selects the internal triggering source signal. Also select the EXT HOR input signal.



CH1 X-Y : When the VERT mode switch (14) is set at the DUAL or ADD position, selects CH1 for the internal triggering source signal. During the X-Y mode operation, selects CH1 for the X-axis signal.

CH2: When the VERT mode switch (14) is set at the DUAL or ADD position, selects CH2 for the internal triggering source signal.

EXT: The external signal applied through EXT TRIG (EXT HOR) input terminal (23) is used for the external triggering source signal. During the X-Y, EXT HOR mode operation, the X-axis operates with the external sweep signal.

Note: When the VERT MODE switch is set to the CH1 or CH2 position, internal triggering source signal selection cannot be made by the SOURCE signal. In such cases, a triggering source signal is set by the VERT MODE switch.

COUPLING

(25)

Select coupling mode between triggering source signal and trigger circuit; select connection of TV sync trigger circuit.

COUPLING

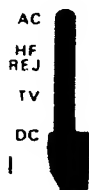

AC: AC coupling

HF REJ: AC coupling, with components higher than 50 kHz rejected.

DC: DC coupling

TV: The trigger circuit is connected to the TV sync separator circuit and the sweeps are synchronized with the TV V or TV H signal at a rate selected by the TIME/DIV switch (30).

For Service Manuals Contact
MAURITRON TECHNICAL SERVICES
8 Cherry Tree Rd, Chinnor
Oxon OX9 4QY
Tel: 01844-351694 Fax: 01844-352554
Email: enquiries@mauritron.co.uk

TV V: 0.5 sec/DIV - 0.1 msec/DIV.

TV H: 50 μ sec/DIV - 0.2 μ sec/DIV.

SLOPE (24) Selects the triggering slope.

SLOPE



"+": Triggering occurs when the triggering signal crosses the triggering level in the direction of signal increase (i. e., positive direction).

"-": Triggering occurs when the triggering signal crosses the triggering level in the direction of signal decrease (i. e., negative direction).

"+" slope

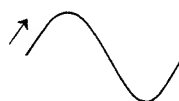

Triggering point

"-" slope

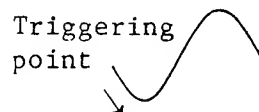

HOLDOFF (21) These double-knob controls are for
LEVEL (22) holdoff time adjustment and triggering level adjustment.

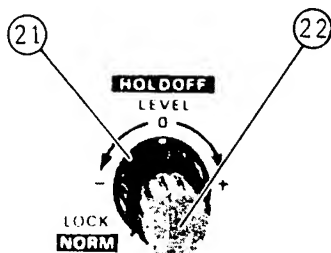

The HOLDOFF time control is used when the signal waveform is complex so that stable triggering cannot be attained with LEVEL knob (22) alone.

The LEVEL knob is for displaying a synchronized stationary waveform and setting a start point for the waveform.

As this knob is turned in "→ +" direction, the triggering level moves upward on the displayed waveform; as the knob is turned in "← -", the triggering level moves downward.

When set at the LOCK position, the triggering level is automatically maintained at the optimum value irrespective of the signal amplitude (from very small amplitude to large amplitude), requiring no manual adjustment of triggering level.

o Time Base

A TIME/DIV AND (30)
 DELAY TIME
 (COS5021 only)

Selects the sweep time for the A sweep or the delay time when in the delayed sweep mode. When this switch is set to the X-Y EXT HOR position, the oscilloscope operates as an X-Y scope with CH1 for the X-axis or operates in the EXT HOR mode with an external sweep input signal for the horizontal signal.

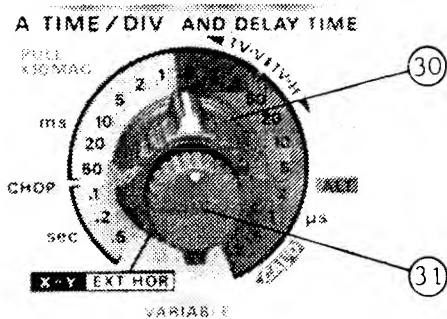

(For details, see Page 28 and 29.)

TIME/DIV (30)
 (COS5020 only)

Selects the sweep time.

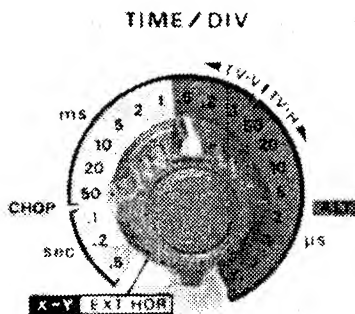

For Service Manuals Contact
MAURITRON TECHNICAL SERVICES
 8 Cherry Tree Rd, Chinnor
 Oxon OX9 4QY
 Tel:- 01844-351694 Fax:- 01844-352554
 Email:- enquiries@mauritron.co.uk

VARIABLE (31)
 PULL ×10 MAG

Vernier control of sweep time (the A sweep for COS5021). The sweep time can be made slower by a factor of 2.5 or more of the panel-indicated value.

The panel-indicated values are calibrated with this knob set in the CAL'D position.

The pulled out position of this knob is for the $\times 10$ MAG state.

POSITION (32) Vertical adjustment of the trace or spot.

B TIME/DIV (33) Selects the sweep time for delayed sweep (B sweep).

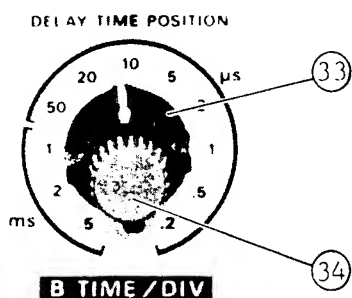

DELAY TIME POSITION.. (34) Vernier control of the delay time selected by the A TIME/DIV AND DELAY TIME switch (30), to finely select the portion of the A sweep waveform to be magnified.

SWEEP MODE (28) Selects the desired sweep mode.

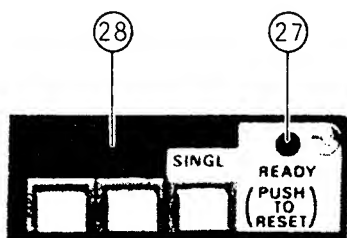

AUTO: When no triggering signal is applied or when triggering signal frequency is less than 50 Hz, sweep runs in the free run mode.

NORM: When no triggering signal is applied, sweep is in a ready state and the trace is blanked out. Used primarily for observation of signals of 50 Hz or lower.

SINGLE: Used for single sweep
PUSH operation (one-shot sweep
TO operation), and in common
RESET as the reset switch.

When the three buttons are in the pushed out state, the circuit is in the single sweep mode. The circuit is reset as this button is pressed. When the circuit is reset, the READY lamp (27) turns on. The lamp goes off when the single sweep operation is over.

HOR DISPLAY (29) Selects A and B sweep mode as follows:
(COS5021 only)

A: Main sweep (A sweep) mode for general waveform observation.

A INT: This sweep mode is used when selecting the section to be magnified of the A sweep, in preparation for delayed sweep. The B sweep section (delayed sweep) corresponding to the A sweep is displayed with high brightness.

B: Displays the delayed sweep (B sweep) alone.

B TRIG'D: Selects between continuous delay and triggered delay.

\square : For continuous delay. The B sweep starts immediately after the sweep delay time set by DELAY TIME switch (30) and DELAY TIME POSITION knob (34) has elapsed.

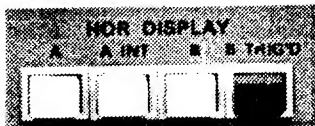

For Service Manuals Contact
MAURITRON TECHNICAL SERVICES
8 Cherry Tree Rd, Chinnor
Oxon OX9 4QY
Tel: 01844-351694 Fax: 01844-352554
Email: enquiries@mauritron.co.uk

□: For triggered delay. The B sweep starts when the triggering pulse is applied after the sweep delay time set by DELAY TIME switch and DELAY TIME POSITION knob has elapsed.

(The triggering signal is used in common for both A sweep and B sweep.)

o Others

CAL (Vp-p) ① This terminal delivers the calibration voltage of 2 Vp-p, approximately 1 kHz, positive square wave. The output resistance is approximately 2 kΩ.

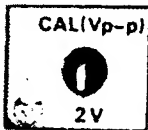

..... ⑮ Ground terminal of oscilloscope mainframe.

4.2 Explanation of Rear Panel

o Z AXIS INPUT ⑳ Input terminals for external intensity modulation signal.

o CH1 SIGNAL OUTPUT ... ㉑ Delivers the CH1 signal with a voltage of approximately 100 mV per 1 DIV of graticule. When terminated with 50 ohms, the signal is attenuated to about a half. May be used for frequency counting, etc.

o AC Power Input Circuit

AC power input connector ... (40)

Input connector of the AC power of the instrument. Connect the AC power cord (supplied) to this connector.

FUSE (41) Fuse in the primary circuit of the power transformer. Fuse rating is as shown in Table (44) .

AC voltage selecting connector ... (42)

For selecting the AC voltage of the instrument.

AC voltage selector plug ... (43)

For selecting the AC voltage of the instrument by aligning its arrowhead mark in the corresponding position as shown in Table (44) .

o Studs (39) Studs for laying the oscilloscope on its back to operate it in the upward posture. Also used to take up the power cord.

For Service Manuals Contact
MAURITRON TECHNICAL SERVICES
8 Cherry Tree Rd, Chinnor
Oxon OX9 4QY
Tel: 01844-351694 Fax: 01844-352554
Email: enquires@mauritron.co.uk

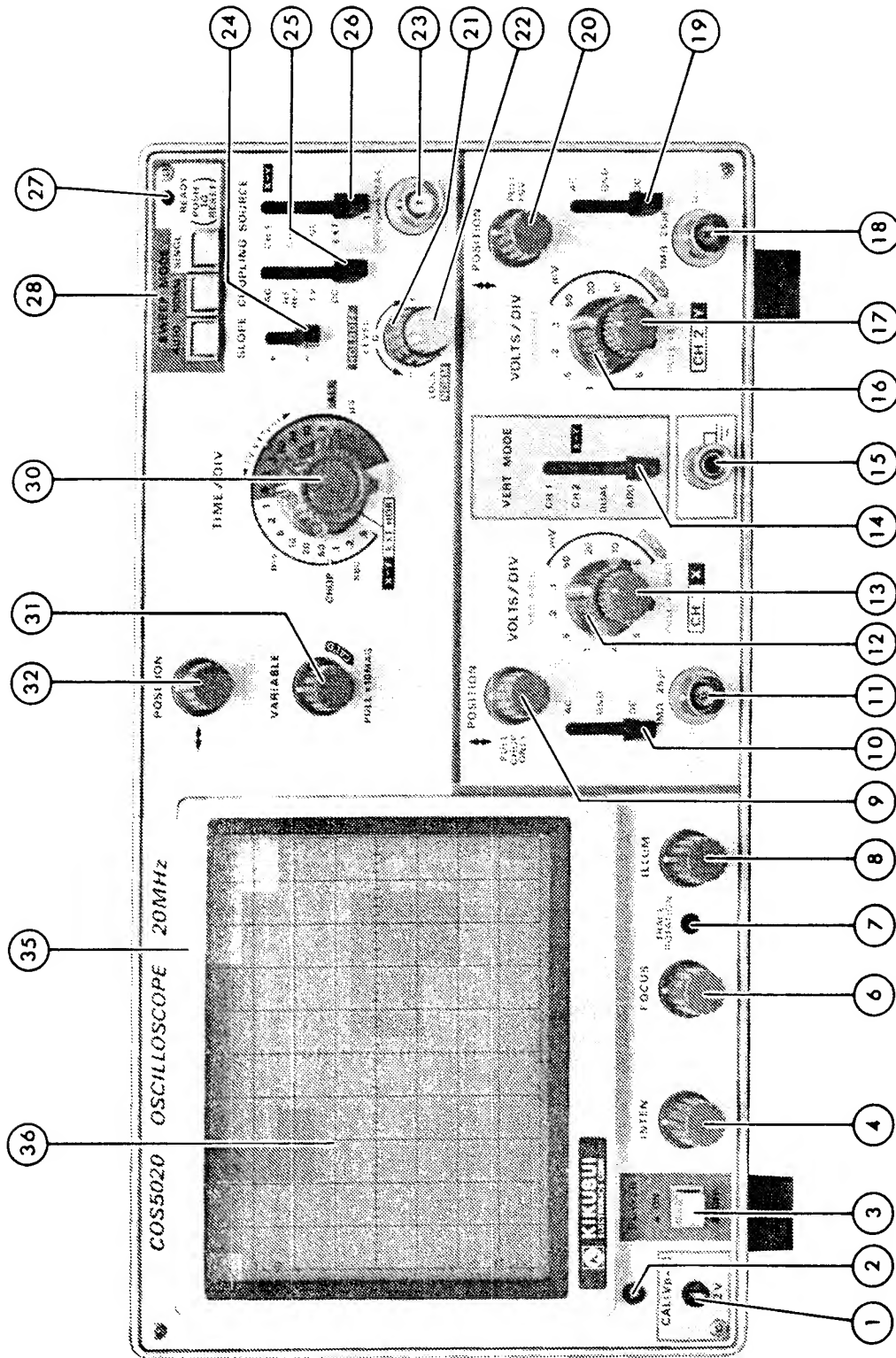

Figure 4-1 (Model COS5020)

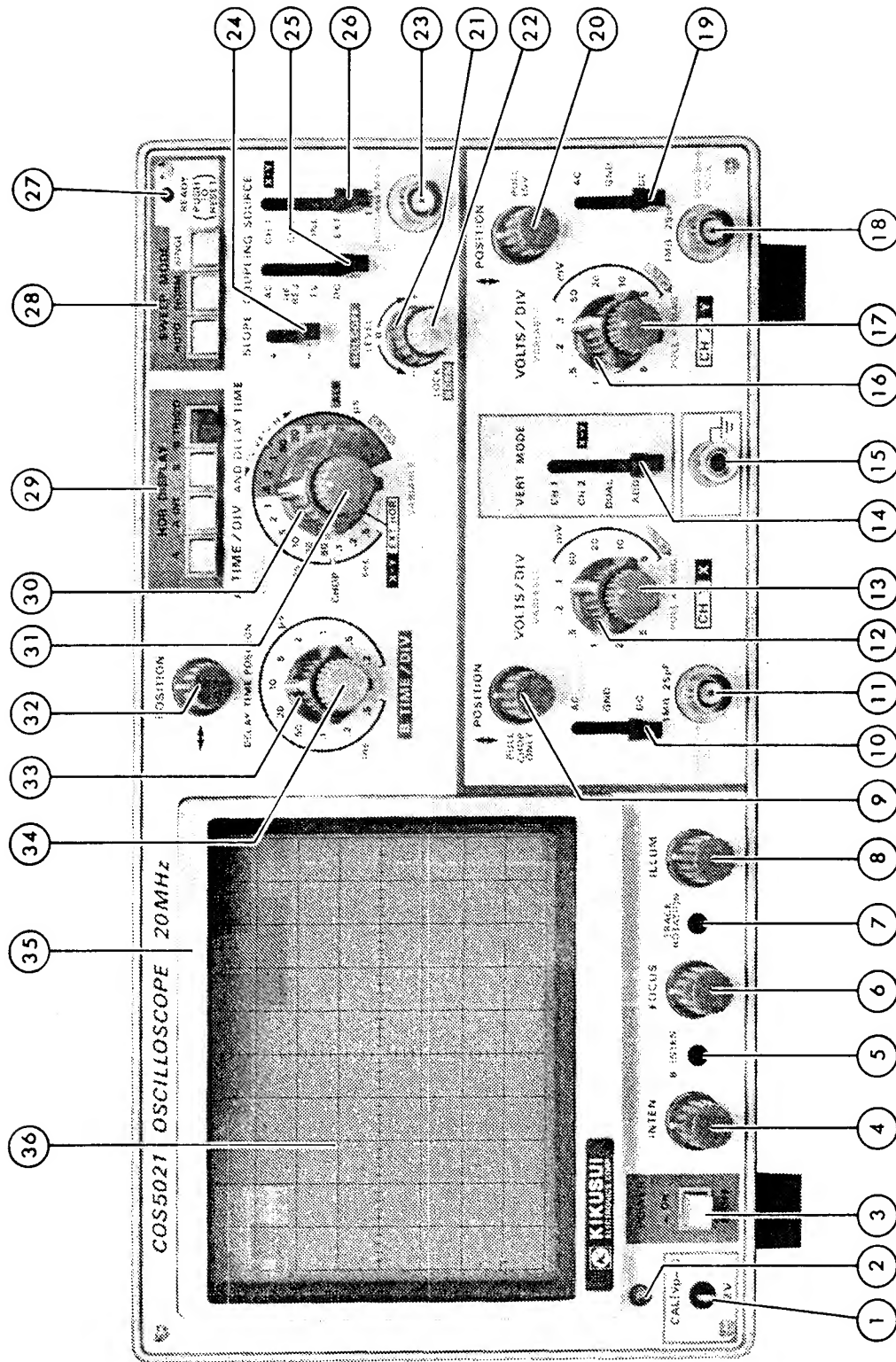

Figure 4-2 (Model COS5021)

For Service Manuals Contact
MAURITRON TECHNICAL SERVICES
 8 Cherry Tree Rd, Chinnor
 Oxon OX9 4QY
 Tel: 01844-351694 Fax: 01844-352554
 Email: enquiries@mauriton.co.uk

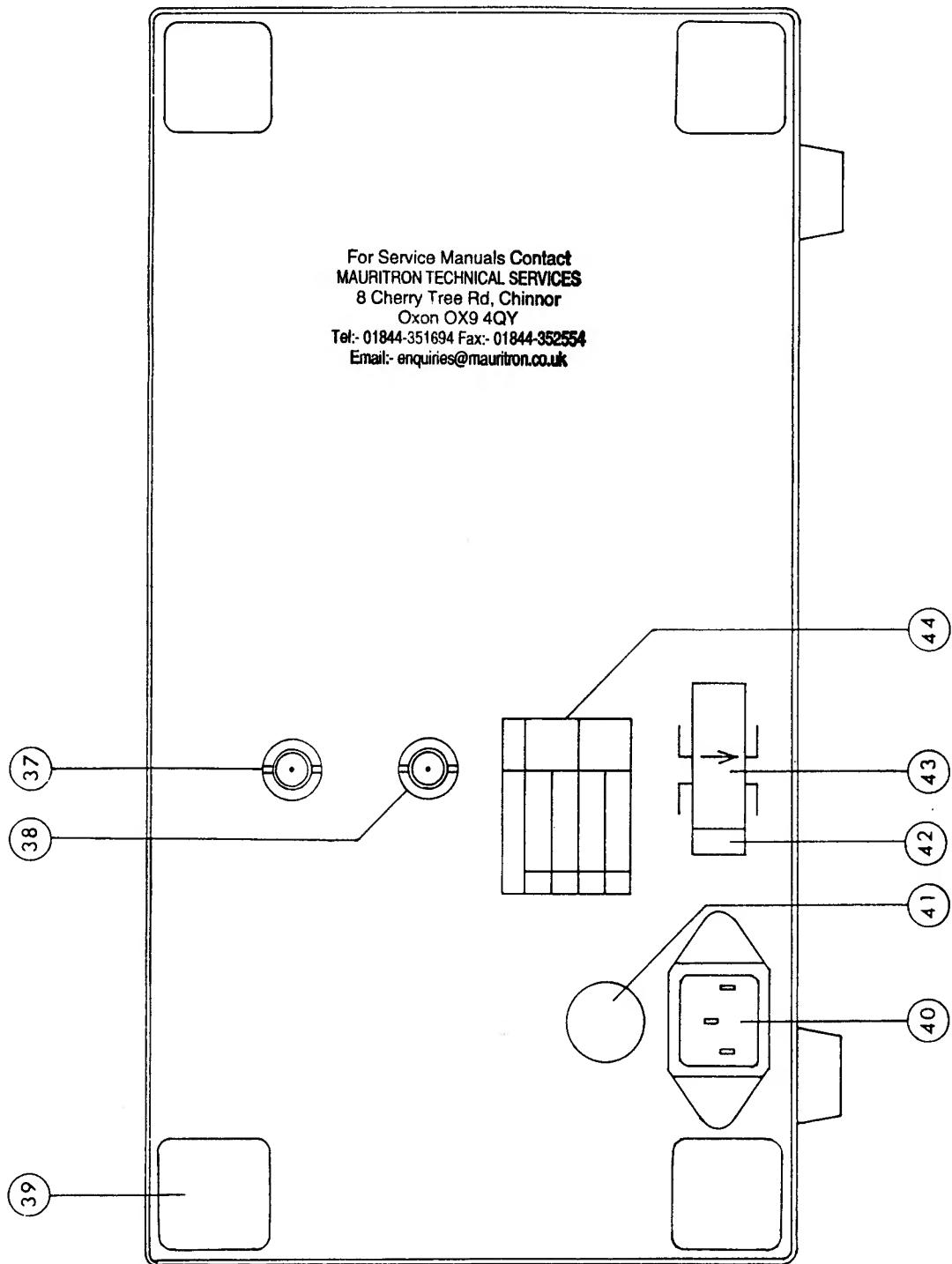

Figure 4-3

4.3 Basic Operation

Before connecting the power cord to an AC line outlet, check that the AC line voltage selector plug on the rear panel of the instrument is correctly set for the AC line voltage. After ensuring the voltage setting, set the switches and controls of the instrument as shown in the following table.

| Item | No. | Setting |
|-------------|-----|---------------------------------------|
| POWER | ③ | ⏏ OFF position |
| INTEN | ④ | Clockwise (3-o'clock position) |
| FOCUS | ⑥ | Mid-position |
| ILLUM | ⑧ | Counterclockwise position |
| VERT MODE | ⑭ | CH1 |
| ↕ POSITION | ⑨ ⑳ | Mid-position, pushed in |
| VOLTS/DIV | ⑫ ⑰ | 500 mV/DIV |
| VARIABLE | ⑬ ⑱ | CAL'D (clockwise position), pushed in |
| AC-GND-DC | ⑩ ⑲ | GND |
| SOURCE | ⑳ | Be selected automatically to CH1 |
| COUPLING | ㉕ | AC |
| SLOPE | ㉔ | + |
| LEVEL | ㉒ | LOCK (counterclockwise) |
| HOLD OFF | ㉑ | NORM (counterclockwise) |
| SWEEP MODE | ㉘ | AUTO |
| HOR DISPLAY | ㉙ | A (COS5021 only) |
| TIME/DIV | ㉚ | 0.5 msec/DIV |
| VARIABLE | ㉛ | CAL'D (clockwise), pushed in |
| ↔ POSITION | ㉜ | Mid-position |

After setting the switches and controls as indicated above, connect the power cord to the AC line outlet and, then, proceed as follows:

- 1) Turn-ON the POWER switch and make sure that the power pilot LED is turned on. In about 20 seconds, a trace will appear on the CRT screen. If no trace appears even after about 60 seconds, repeat the switch and control settings as shown in the above table.
- 2) Adjust the trace to an appropriate brightness and to the sharpest image with the INTEN control and FOCUS control.
- 3) Align the trace with the horizontal center line of graticule by adjusting the CH1 POSITION control and TRACE ROTATION control (screwdriver adjustment).
- 4) Connect the probe (supplied) to the CH1 INPUT terminal, and apply the 2 V_{p-p} CALIBRATOR signal to the probe tip.
- 5) Set the AC-GND-DC switch in the AC state. A waveform as shown in Figure 4-4 will be displayed on the CRT screen.

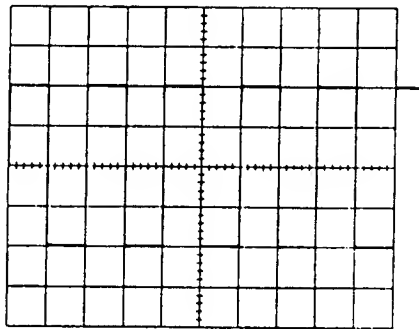

Figure 4-4

- 6) Adjust the FOCUS control until the sharpest trace image becomes available.
- 7) For signal viewing, adjust the VOLTS/DIV switch and TIME/DIV switch to appropriate positions so that the signal waveform is displayed with an appropriate amplitude and an appropriate number of peaks.

For Service Manuals Contact
MAURITRON TECHNICAL SERVICES
8 Cherry Tree Rd, Chinnor
Oxon OX9 4QY
Tel: 01844-351694 Fax: 01844-352554
Email: enquiries@mauritron.co.uk

- 8) Adjust the \updownarrow POSITION and \leftrightarrow POSITION controls to appropriate positions so that the displayed waveform is aligned with the graticule and the voltage (V_p-p) and period (T) can be read as desired.

The above procedure is the basic operating procedure of the oscilloscope for single-channel operation with CH1. Single-channel operation with CH2 also can be made in a similar manner. Further operation methods are explained in the subsequent paragraphs.

4.4 Dual-channel Operation

Change the VERT MODE switch to the DUAL position so that the other trace (CH2) also is displayed. (The trace explained in the preceding section was for CH1.) At this state of procedure, the CH1 trace has the square wave of the calibration signal and the CH2 trace has a straight line since no signal is applied to this channel yet.

Now, apply the calibration signal also to the vertical input terminal of CH2 with the probe as was the case for CH1. Set the AC-GND-DC switch at the AC position. Adjust vertical POSITION knobs (9) and (20) so that two channels of signals are displayed as shown in Figure 4-5.

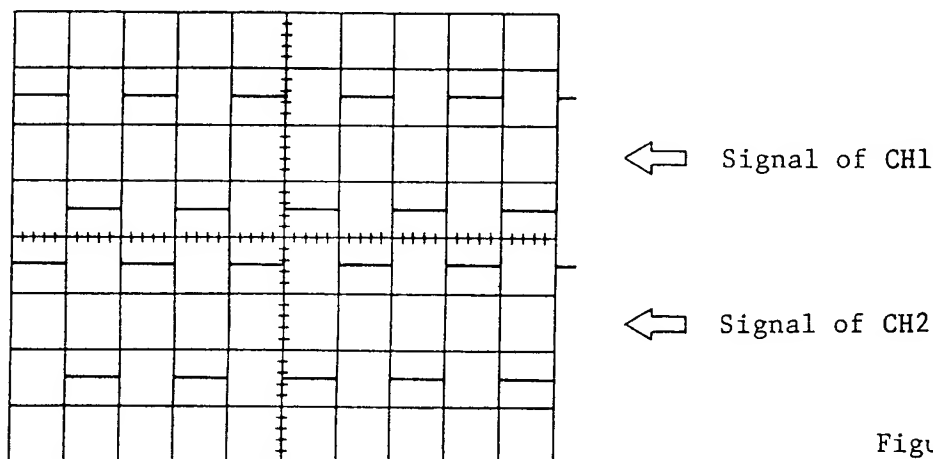
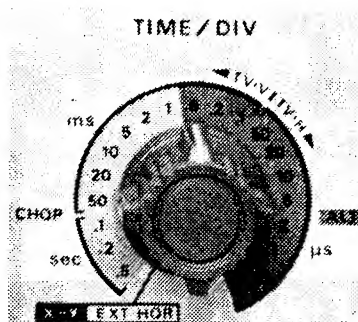

Figure 4-5

During the dual-channel operation (DUAL or ADD mode), either the CH1 or CH2 signal must be selected as the triggering source signal by means of the SOURCE switch. If both CH1 and CH2 signals are in a synchronized state, both waveforms can be displayed stationary; if not, only the signal selected by the SOURCE switch can be displayed stationary.

Selection between CHOP mode and ALT mode is automatically made by the TIME/DIV switch. The 1 msec/DIV and lower ranges are used with the CHOP operation and the 0.5 msec/DIV and higher ranges are used with the ALT operation.

Figure 4-6



When the \updownarrow POSITION knob is pulled out, the two traces are displayed with the CHOP operation over the entire ranges.

4.5 ADD Operation

An algebraic sum of the CH1 and CH2 signals can be displayed on the screen by setting the VERT MODE switch at the ADD position. The displayed signal becomes the difference between CH1 and CH2 signals if the CH2 POSITION knob is pulled out (PULL INV).

For accurate addition or subtraction, it is a prerequisite that the sensitivities of the two channels be adjusted accurately at the same value by means of the VARIABLE knobs. Vertical positioning can be made with the \updownarrow POSITION knob of either channel. In view of the linearities of the vertical amplifiers, it is most advantageous to set both knobs in their mid-positions.

4.6 X-Y Operation and EXT HOR Operation

When the TIME/DIV switch is set at the X-Y EXT HOR position, the internal sweep circuit is disconnected and the trace in the horizontal direction is driven by the signal selected by the SOURCE switch.

When the switch is set to the CH1 X-Y position, the oscilloscope operates as an X-Y scope with the CH1 signal for the X-axis; when it is set to the EXT position, the oscilloscope operates in the EXT HOR (external sweep) mode.

For Service Manuals Contact
MAURITRON TECHNICAL SERVICES
8 Cherry Tree Rd, Chinnor
Oxon OX9 4QY
Tel:- 01844-351694 Fax:- 01844-352554
Email:- enquiries@mauritron.co.uk

o X-Y operation

The X-Y mode is operated with the VERT MODE switch selected for CH2 $\boxed{\text{X-Y}}$ and the TIME/DIV switch in the fully counter clockwise position. CH1 becomes the X axis while CH2 becomes the Y axis, whose position is controlled by the horizontal position knob. The bandwidth of the X axis becomes DC to 1 MHz (-3 dB).

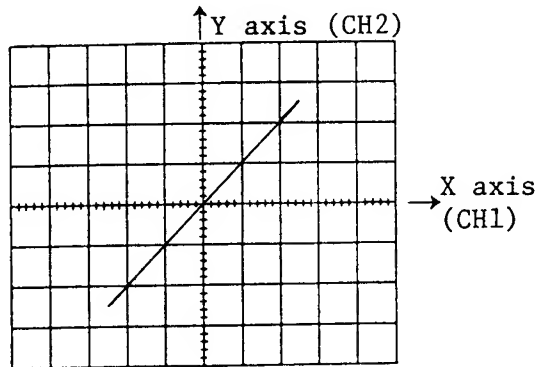

Figure 4-7

o EXT HOR (external sweep) operation

The external signal applied through the EXT HOR terminal (23) drives the X axis. The Y axis is controlled with any channel or channels as selected by the VERT MODE switch. When the DUAL mode is selected by the switch, both CH1 and CH2 signals are displayed in the CHOP mode.

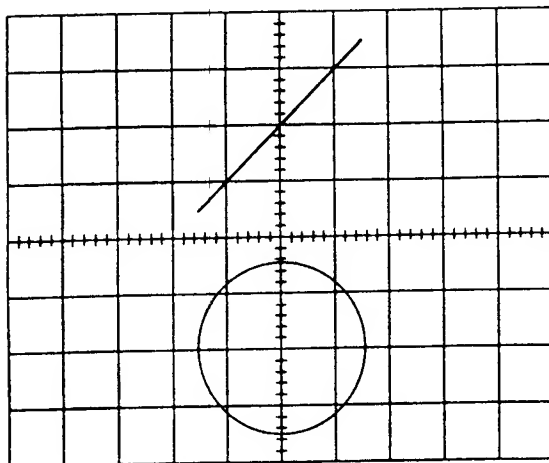

Figure 4-8. Dual-channel X-Y operation

4.7 Triggering

Proper triggering is essential for an efficient operation of the oscilloscope. The user of the oscilloscope must become thoroughly familiar with the triggering functions and procedures.

(1) Functions of SOURCE Switch:

To display a stationary pattern on the CRT screen, the displayed signal itself or a trigger signal which has a time relationship with the displayed signal is required to be applied to the trigger circuit. The SOURCE switch selects such a triggering source.

CH1: This internal trigger method is used most commonly. The CH2: signal applied to the vertical input terminal is branched off from the preamplifier and is fed to the trigger circuit through the VERT MODE switch. Since the triggering signal is the measured signal itself, a very stable waveform can be readily displayed on the CRT screen.

During the single-sweep mode operation, the signal of the channel selected by the VERT MODE switch is used as the triggering source signal.

During the DUAL or ADD operation, the signal selected by the SOURCE switch is used as the triggering source signal.

LINE: The AC power line frequency signal can also be used as the triggering signal. This method is effective when the measured signal has a close relationship with the AC line frequency, especially for measurements of low level AC noise of audio equipment, thyristor circuits, etc.

EXT: The sweep is triggered with an external signal applied to the external trigger input terminal. An external signal which has a periodic relationship with respect to the measured signal is used. Since the measured signal is not used as the triggering signal, waveform can be displayed more independently of the measured signal.

The above triggering source signal selection function are summarized in the following table.

| VERT MODE SOURCE | CH1 | CH2 | DUAL | ADD |
|---------------------|------------------------------------|-------------------------------|-------------------------|-----|
| CH1 | Triggered by CH1 signal | Triggered by CH2 signal | Triggered by CH1 signal | |
| CH2 | | | Triggered by CH2 signal | |
| LINE | Triggered by LINE signal | | | |
| EXT | Triggered by EXT TRIG input signal | | | |

(2) Functions of COUPLING switch:

This switch is used to select the coupling of the triggering signal to the trigger circuit in accordance with the characteristics of the measured signal.

AC: This coupling is used for AC triggering which is used most commonly. As the triggering signal is applied to the trigger circuit through an AC coupling circuit, stable triggering can be attained without being affected by the DC component of the input signal. The low-range cut off frequency is 10 Hz (-3 dB).

**For Service Manuals Contact
MAURITRON TECHNICAL SERVICES
8 Cherry Tree Rd, Chinnor
Oxon OX9 4QY
Tel: 01844-351694 Fax: 01844-352554
Email: enquiries@mauritron.co.uk**

When the ALT trigger mode is used and the sweep speed is slow, jitter may be produced. In such a case, use the DC mode.

HF REJ: The triggering signal is fed to the trigger circuit through an AC coupling circuit and a low pass filter (approximately 50 kHz, -3 dB). The higher components of the trigger signal are rejected through the low pass filter and the lower components alone of the trigger signal are applied to the trigger circuit.

TV: This coupling is used for TV triggering for observation of TV video signals. The triggering signal is AC-coupled and fed via the trigger circuit (level circuit) to the TV sync separator circuit. The separator circuit picks

off the sync signal, which is used to trigger the sweep. Thus, the video signal can be displayed very stably.

Being linked to the TIME/DIV switch, the sweep speed is switched for TV.V and TV.H as follows:

TV.V: 0.5 sec - 0.1 msec

TV.H: 50 μ sec - 0.2 μ sec

The SLOPE switch should be set in conformity with the video signal as shown in Figure 4-9.

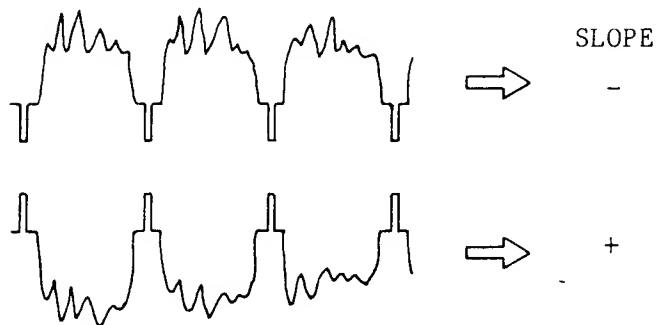

Figure 4-9

DC: The triggering signal is DC-coupled to the trigger circuit. This mode is used when triggering is desired with the DC component of the triggering signal or when a very low frequency signal or a signal of large duty cycle ratio is needed to be displayed.

(3) Functions of SLOPE switch:

This switch selects the slope (polarity) of the triggering signal.

"+": When set in the "+" state, triggering occurs as the triggering signal crosses the triggering level in the direction of signal increase (i.e, positive direction).

"-": When set in the "-" state, triggering occurs as the triggering signal crosses the triggering level in the direction of signal decrease (i.e, negative direction).

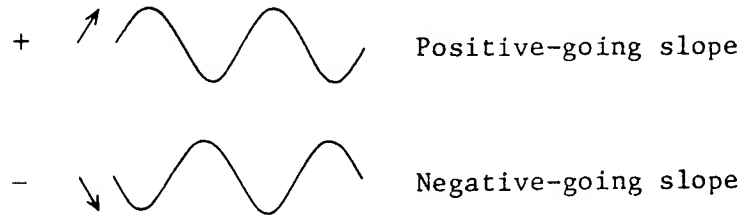

Figure 4-10

(4) Functions of LEVEL (LOCK) control:

The function of this control is to adjust the triggering level and display a stationary image. At the instant of the triggering signal crossing the triggering level set by this control, the sweep is triggered and a waveform is displayed on the screen.

The trigger level changes in the positive direction (upward) as this control knob is turned clockwise and it changes in the negative direction (downward) as the knob is turned counter-clockwise. The rate of change is set as shown in Figure 4-11.

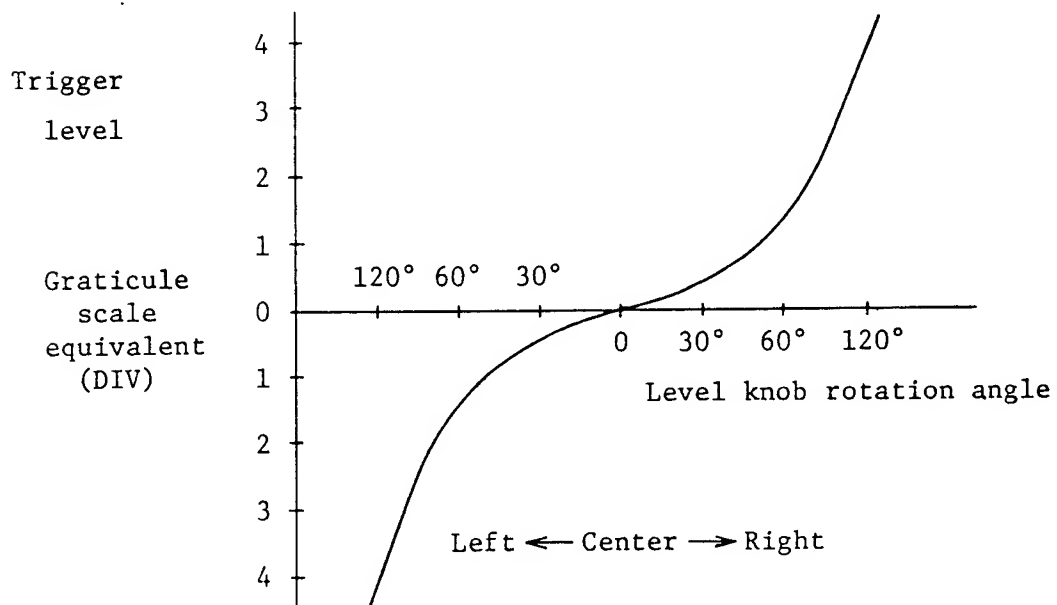

Figure 4-11

For Service Manuals Contact
MAURITRON TECHNICAL SERVICES
 8 Cherry Tree Rd, Chinnor
 Oxon OX9 4QY
 Tel:- 01844-351694 Fax:- 01844-352554
 Email: enquiries@mauritron.co.uk

o LEVEL LOCK

When the LEVEL knob is set at the LEVEL LOCK position, the triggering level is automatically maintained within the amplitude of the triggering signal and stable triggering is made without requiring level adjustment (although jitter may not be suppressed during the ALT mode operation). This automatic level lock function is effective when the signal amplitude on the screen or the input voltage of the external triggering signal is within the following range:

50 Hz - 10 MHz: 1.0 DIV (0.15 V) or less

50 Hz - 20 MHz: 2.0 DIV (0.25 V) or less

(5) Functions of HOLD OFF control:

When the measured signal has a complex waveform with two or more repetition frequencies (periods), triggering with the above-mentioned LEVEL control alone may not be sufficient for attaining a stable waveform display. In such a case, the sweep can be stably synchronized to the measured signal waveform by adjusting the HOLD OFF time (sweep pause time) of the sweep waveform. The control covers at least the time of one full sweep, for sweeps faster than 0.2 sec/DIV.

Figure 4-11 (1) shows a case for HOLD OFF knob at the NORM position. Various different waveforms are overlapped on the screen, making the signal observation unsuccessful.

Figure 4-11 (2) shows a case in which the undesirable portion of the signal is held off. The same waveforms are displayed on the screen without overlapping.

For Service Manuals Contact
MAURITRON TECHNICAL SERVICES
8 Cherry Tree Rd, Chinnor
Oxon OX9 4QY
Tel:- 01844-351694 Fax:- 01844-352554
Email:- enquiries@mauritron.co.uk

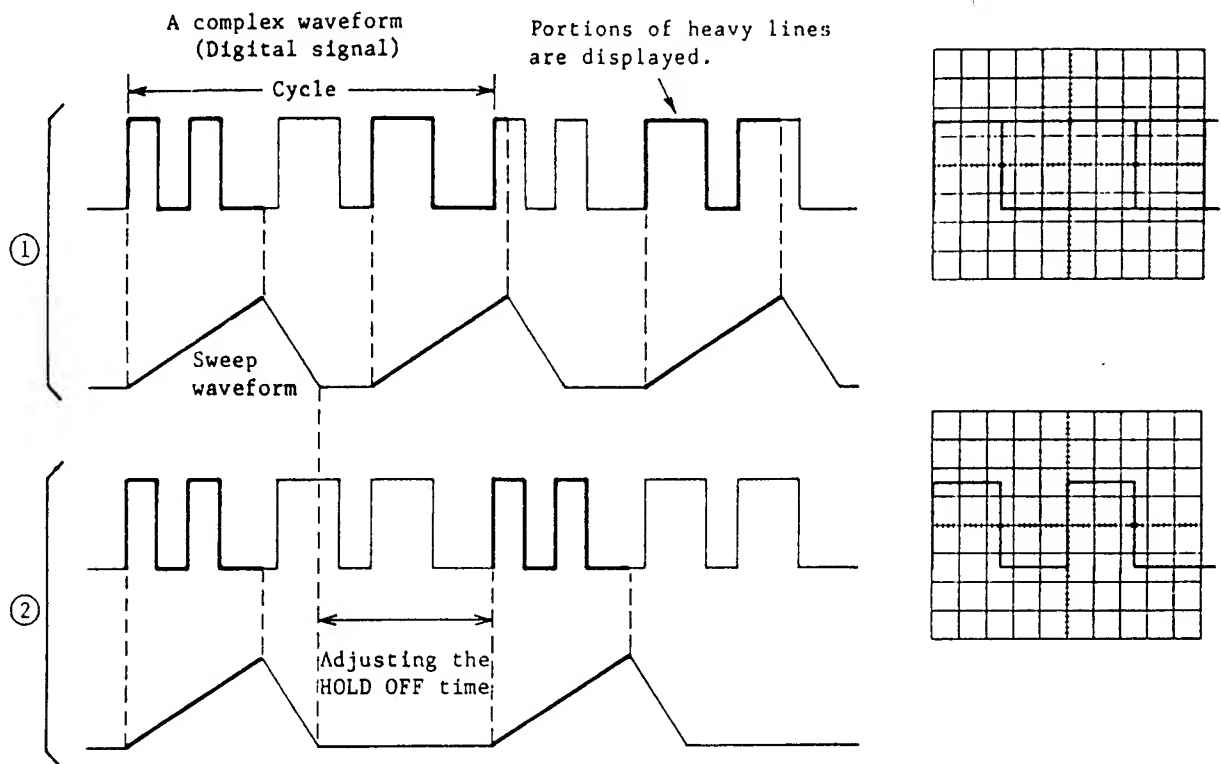

Figure 4-12

For Service Manuals Contact
MAURITRON TECHNICAL SERVICES
 8 Cherry Tree Rd, Chinnor
 Oxon OX9 4QY
 Tel:- 01844-351694 Fax:- 01844-352554
 Email:- enquiries@mauritron.co.uk

4.8 Single-sweep Operation

Non-repetitive signals and one-shot transient signals can hardly be observed on the screen with the regular repetitive sweep operation. Such signals can be measured by displaying them in the single-sweep mode on the screen and photographing them.

o Measurement of non-repetitive signal:

- (1) Set the SWEEP MODE at the NORM position.
- (2) Apply the measured signal to the vertical input terminal and adjust the triggering level.
- (3) Set the SWEEP MODE at the SINGLE position (the three pushbutton switches are pushed out). *

(4) Press the RESET button. The sweep will run only for one cycle and measured signal will be displayed only once on the screen.

o Measurement of one-shot signal:

- (1) Set the SWEEP MODE at the NORM position.
- (2) Apply the calibration output signal to the vertical input terminal, and adjust the triggering level at a value corresponding to the predicted amplitude of the measured signal.
- (3) Set the SWEEP MODE at the SINGLE position. Apply the measured signal, instead of the calibration signal, to the vertical input terminal.
- (4) Depress the RESET button. The sweep circuit will become in the ready state and the READY lamp will light on.
- (5) As the one-shot signal occurs in the input circuit, the sweep runs only for one cycle and the one-shot signal is displayed on the CRT screen.

The single-sweep operation can be done also with A INTEN B sweep. However, it cannot be done in the dual-channel ALT mode operation. For dual-channel one-sweep operation, use the CHOP mode.

4.9 Sweep Magnification

When a certain position of the displayed waveform is needed to be expanded timewise, a faster sweep speed may be used. However, if the required portion is far away from the starting point of the sweep, the required portion may run off the CRT screen. In such a case, pull out (set in the x10 MAG state) the sweep VARIABLE KNOB (31). When this is done, the displayed waveform is expanded by 10 times to right or left with the center of screen at the center of expansion.

For Service Manuals Contact
MAURITRON TECHNICAL SERVICES
8 Cherry Tree Rd, Chinnor
Oxon OX9 4QY
Tel:- 01844-351694 Fax:- 01844-352554
Email:- enquiries@mauritron.co.uk

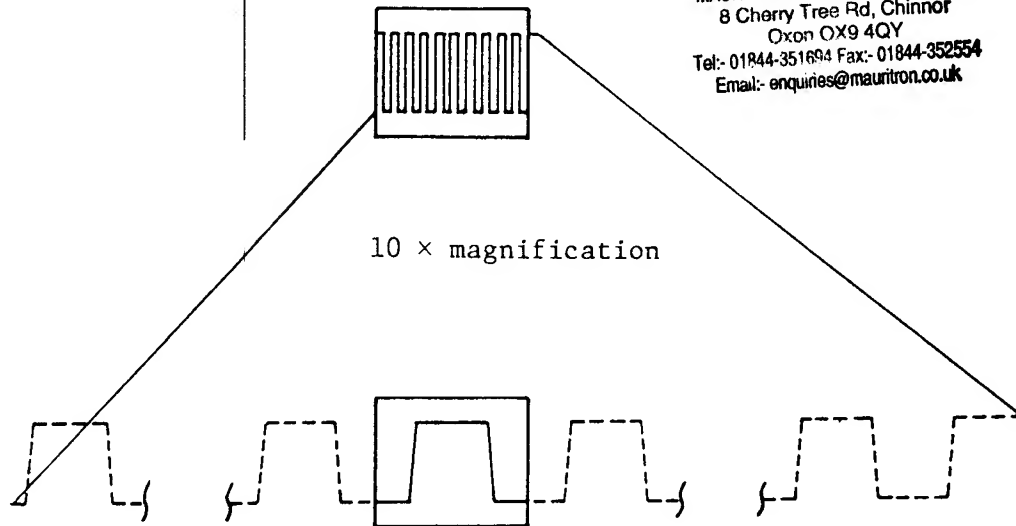

Any portion can be covered by means of
POSITION control.

Figure 4-13

The sweep time during the magnification operation is obtained as follows:

$$(\text{Value indicated by TIME/DIV switch}) \times 1/10$$

Thus, the unmagnified maximum sweep speed ($0.2 \mu\text{sec}/\text{DIV}$) can be made faster with magnification as follows:

$$0.2 \mu\text{sec}/\text{DIV} \times 1/10 = 20 \text{ nsec}/\text{DIV}$$

When the sweep is magnified and the sweep speed has become faster than $0.2 \mu\text{sec}/\text{DIV}$, the trace may become darker. In such a case, the displayed waveform should be expanded in the B sweep mode explained in the subsequent paragraphs (COS5021 only).

4.10 Waveform Magnification with Delayed Sweep (COS5021 only).

With sweep magnification of the preceding paragraph, although the magnification method is simple, the magnification ratio is limited at 10. With the delayed sweep method of this paragraph, on the other hand, the sweep can be expanded for a wide range from several times to several thousand times according to the ratio between A sweep time and B sweep time.

As the measured signal frequency becomes high and the A sweep range for the non-expanded signal becomes higher, the available expansion ratio becomes smaller. Furthermore, as the magnification ratio becomes larger, the trace intensity becomes lower and the delay jitter increases. To cope with these situations, a continuously-variable delay circuit and a triggered delay circuit are incorporated into the oscilloscope.

(1) Continuously-variably delay:

Set the HOR DISPLAY switch to A and display the signal waveform with the A sweep in the regular operation method.

Next, set the B TIME/DIV switch at a position faster by several steps than the A TIME/DIV switch.

After ensuring that the B TRIG'D button of the HOR DISPLAY switch is at the pushed out position () , turn the HOR DISPLAY switch to the A INTEN position. A portion of the displayed waveform will be accentuated as shown in Figure 4-14, indicating the state ready for delayed sweep. The portion of the accentuated brightness indicates the section corresponding to the B sweep time (DELAYED SWEEP). This portion is expanded on the B sweep.

The period from the start of the A sweep to that of the B sweep (the period to the start of trace accentuation) is called "SEEP DELAY TIME." This period is continuously variable by means of the DELAY TIME POSITION knob.

Next, change the HOR DISPLAY switch to the B position. The B sweep time will be expanded for the full span of the CRT screen as shown in Figure 4-15.

The B sweep time is set by the B TIME/DIV switch and the magnification ratio becomes as follows:

$$\text{Magnification ratio} = \frac{\text{A TIME/DIV indication}}{\text{B TIME/DIV indication}}$$

The sweep delay time can be read on the CRT screen. For more accurate determination, the DELAY TIME MULTI dial should be used.

$$\text{Sweep delay time} = \text{A TIME/DIV indication} \times \text{DELAY TIME MULTI dial setting}$$

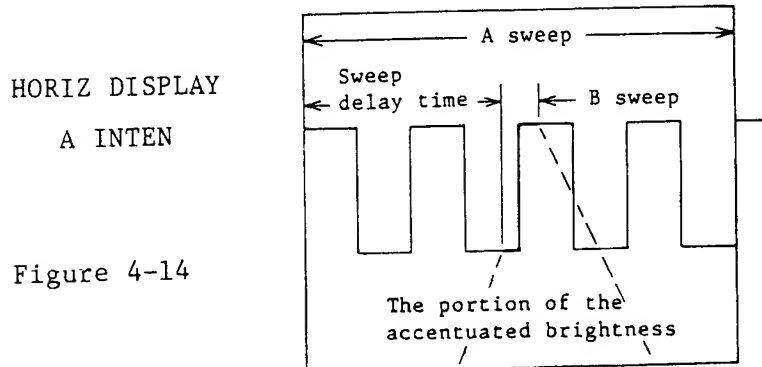

HORIZ DISPLAY
B

Figure 4-15

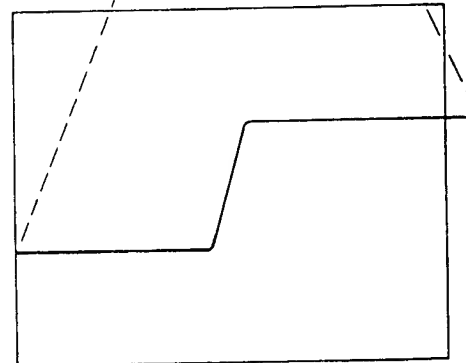

(2) Triggered delay:

When the displayed waveform is magnified by 100 times or higher in the above-mentioned continuous delay method, delay jitter is produced. To suppress the jitter, the triggered delay method may be used.

With the triggered delay, delay jitter is reduced by triggering the B sweep again after a sweep delay time as effected by the continuous delay method has elapsed.

For Service Manuals Contact
MAURITRON TECHNICAL SERVICES
8 Cherry Tree Rd, Chinnor
Oxon OX9 4QY
Tel:- 01844-351694 Fax:- 01844-352554
Email:- enquiries@mauritron.co.uk

For this operation the A trigger circuit continues to operate even after the B TRIG'D button is pushed in (⏏) and the B sweep is triggered by the triggering pulse. Therefore, even when the delay time is continuously varied by turning the TIME DELAY POSITION knob, the starting point of the sweep moves discretely, not continuously. In the A INTEN mode, this operation is characterized by discrete shifts of the brightness-accentuated section of the sweep across the CRT screen; while in the B mode this section remains stationary.

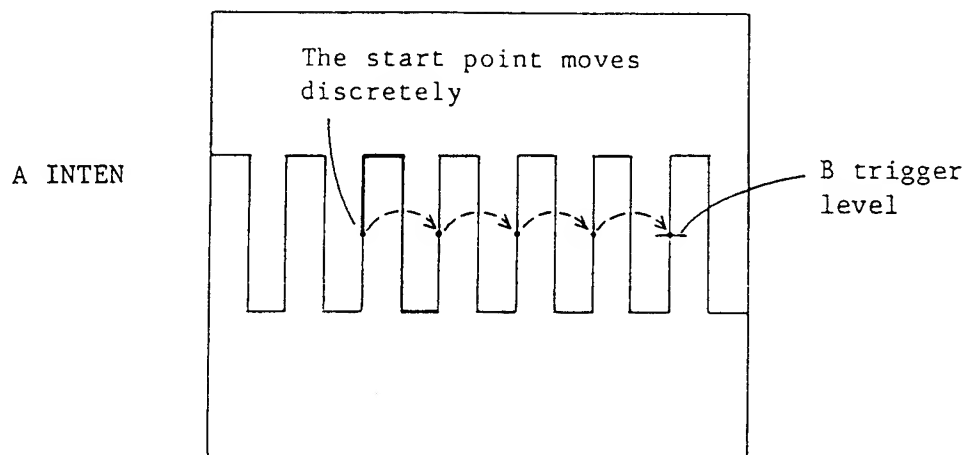

Figure 4-15

For Service Manuals Contact
MAURITRON TECHNICAL SERVICES
8 Cherry Tree Rd, Chinnor
Oxon OX9 4QY
Tel: 01844-351694 Fax: 01844-352554
Email: enquiries@mauritron.co.uk

4.11 Calibration of Probe

As explained previously, the probe makes up a wide-range attenuator. Unless phase compensation is properly done, the displayed waveform is distorted causing measurement errors. Therefore, the probe must be properly compensated before use.

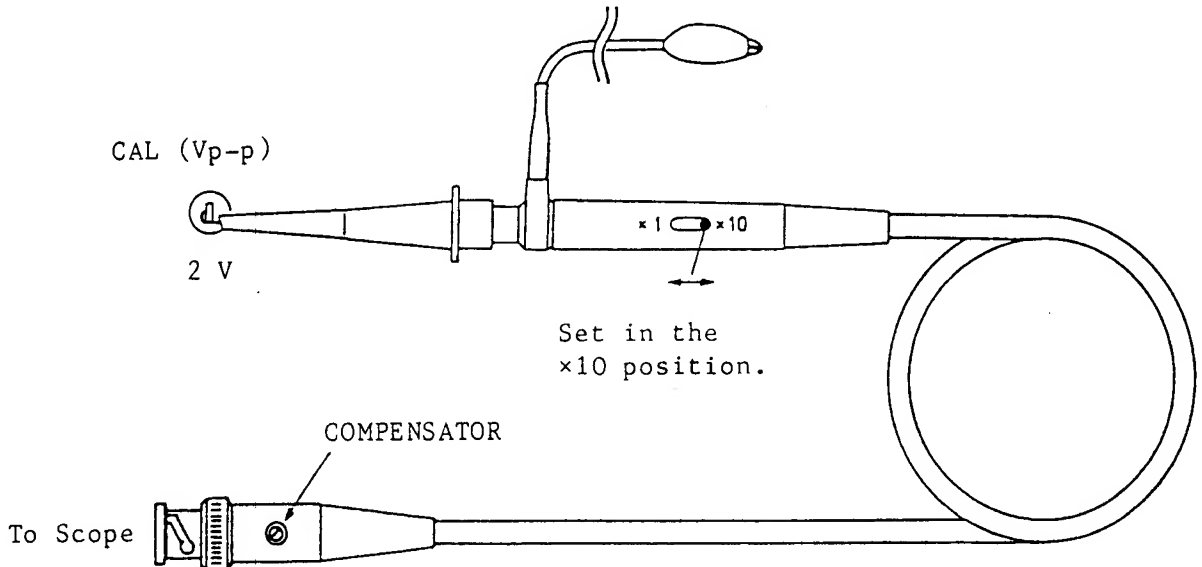

Figure 4-17

Connect the probe BNC to the INPUT terminal of CH1 or CH2 and set VOLTS/DIV switch at 50 mV. Connect the probe tip to the calibration voltage output terminal and adjust the COMPENSATOR control with an insulated screwdriver so that an ideal waveform as illustrated below is obtained.

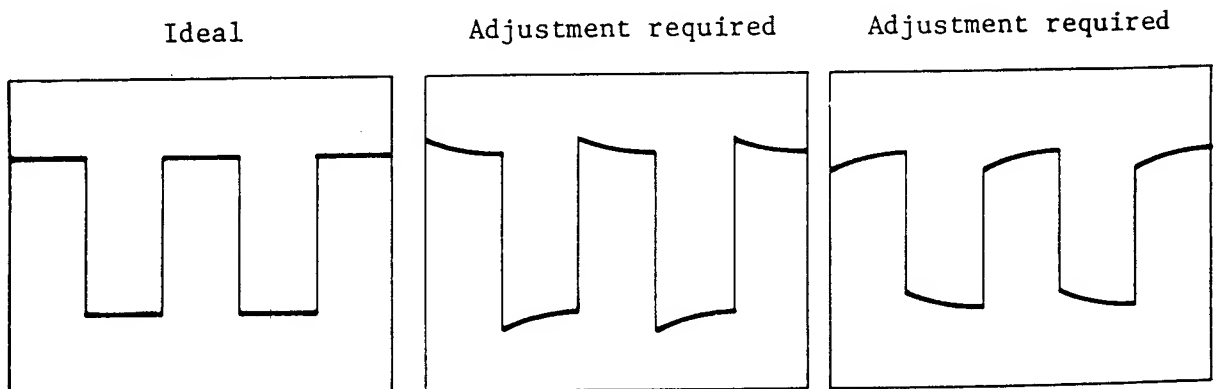

Figure 4-18

5. CIRCUIT DESCRIPTION

5.1 General

The overall circuit structure of the oscilloscope is as depicted with a block diagram in Figure 5-1. It is comprised of a vertical deflection circuit for moving the beam spot in the Y-axis direction on the CRT screen, a horizontal deflection circuit for operating the cathode-ray tube, a calibrator circuit for calibrating the instrument probe, and a power supply circuit for supplying powers to the various circuits of the instrument.

The vertical amplifier circuit has two mutually independent preamplifiers (CH1 and CH2), a vertical switching circuit, a delay line, and a vertical output amplifier.

Each of the preamplifiers amplifies or attenuates its input signal of several millivolts to several hundreds volts into a level suitable for handling by the subsequent stage. The conditioned vertical signals are sent to the vertical switching circuit. The trigger signals also are picked off at this stage.

The vertical switching circuit electronically switches the vertical signals received from the CH1 and CH2 preamplifiers. The switched signal is fed to the vertical output amplifier. The trigger signals also are switched and fed as internal trigger signals to the trigger generator.

The vertical output amplifier amplifies the vertical signal, which is received through the delay line circuit, into a level of several volts to several tens volts for vertically deflecting the beam spot on the CRT screen.

The horizontal deflection circuit has a trigger generator, sweep generators, a horizontal switching circuit, and a horizontal output amplifier.

The trigger generator receives the internal trigger signal from the vertical switching circuit or an external trigger signal from the EXT TRIG INPUT terminal and generates a trigger pulse signal.

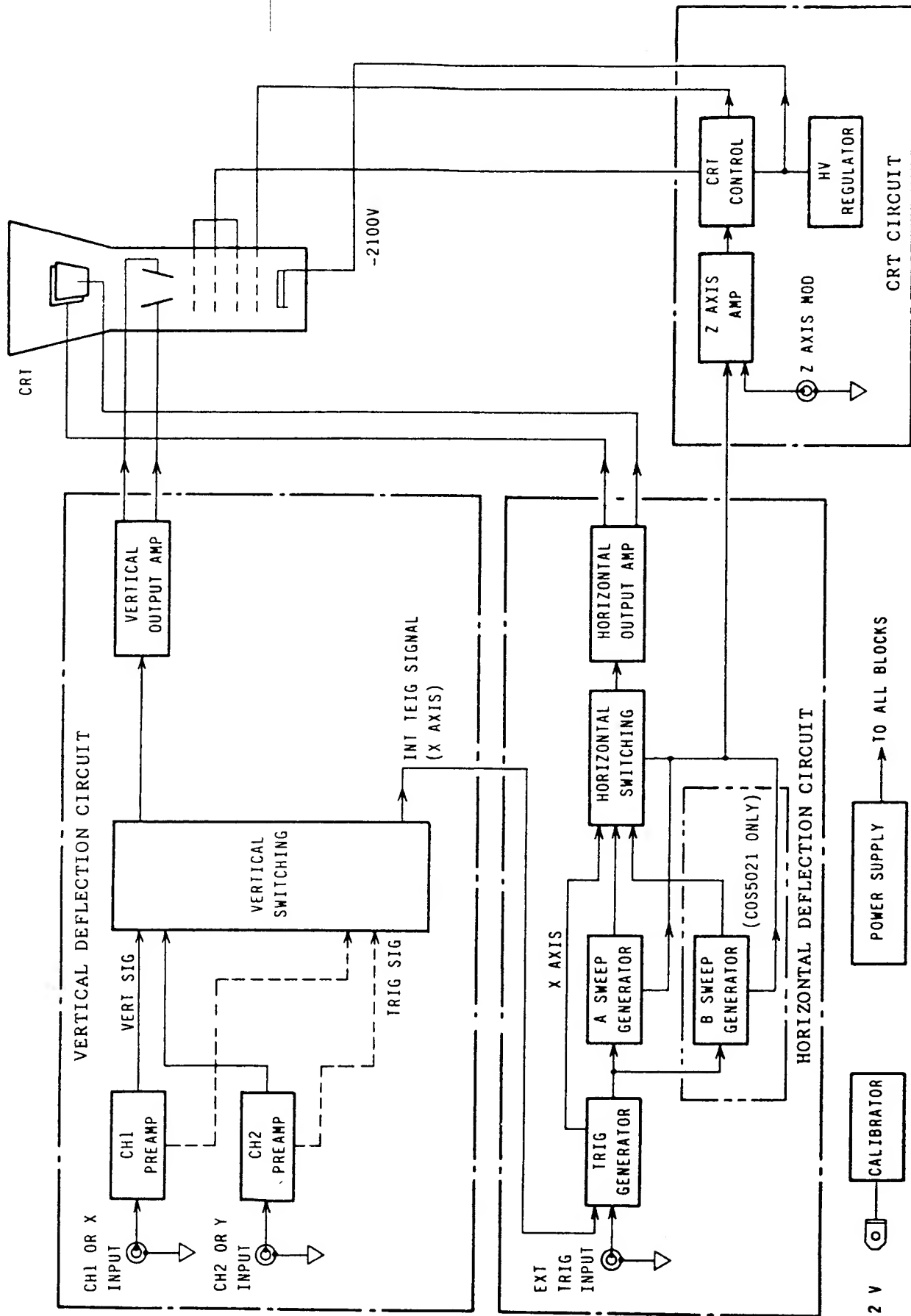

Figure 5-1

The A sweep generator is driven by the trigger pulse signal of the trigger generator and produces the A sawtooth signal. The sweep generator produces a sawtooth signal even when no trigger pulse is applied to it (the AUTO mode).

The B sweep generator produces the B sawtooth signal, being driven by the delayed sweep start signal produced with respect to the A sawtooth signal when in the continuous delay mode (HOR DISPLAY: B). When in the synchronized delay mode (HOR DISPLAY: B TRIG'D), the B sweep generator generates the B sawtooth signal being driven by the trigger pulse signal of trigger generator which follows the above delayed sweep start signal. (COS5021 ONLY)

The horizontal switching circuit electronically switches the sawtooth signals received from the A and B sweep generators and the CH1 HOR signal received from the vertical switching circuit when in the X-Y mode of operation, and sends the resultant signal to the horizontal output amplifier.

The horizontal output amplifier amplifies the output signal of the horizontal switching circuit to a level of several volts to several tens volts in order to drive horizontally the beam spot on the CRT screen.

The CRT circuit is comprised of a high voltage generator (the HV regulator) to accelerate the electron beam emitted from the CRT cathode, a Z-axis amplifier to amplify the signal to blank out the return traces, and a CRT control circuit to operate the CRT tube in its optimal state.

The HV regulator provides a 2.1 kV voltage which is applied to the CRT cathode to accelerate the electrons emitted by it.

For Service Manuals Contact
MAURITRON TECHNICAL SERVICES
8 Cherry Tree Rd, Chinnor
Oxon OX9 4QY
Tel: 01844-351694 Fax: 01844-352554
Email: enquiries@mauritron.co.uk

The Z-axis amplifier amplifies the unblanking signals received from the A and B sweep generators and the trace intensity control signal to a level of several tens volts in order to be applied to the 1st grid (control grid) of the CRT via the CRT circuit.

The CRT circuit provides the various voltages for the CRT electrodes so that the CRT operates in an optimal state, displaying sharply-focussed less-distorted signal waveforms. It also conditions the signals received from the Z-axis amplifier and other circuits into levels suitable for application to the CRT.

5.2 Preamplifiers

The CH1 preamplifier amplifies the signal of the CH1 or X input terminal. The CH2 preamplifier amplifies the signal applied to the CH3 or Y input terminal. A detailed block diagram is shown in Figure 5-2.

o Input coupling switch:

The input coupling switch (S102/S202) selects the input coupling mode for AC, GND, or DC. When the GND state is selected, the preamplifier input is isolated from the input terminal and is grounded so that the base line (0 level) on the CRT screen can be checked.

o Attenuators:

Each of the CH1 and CH2 attenuator circuits consists of two attenuators: The 1st attenuator for 1/1, 1/10 and 1/100, and the 2nd attenuator for 1/1, 1/2, 1/4 and 1/10. By switching these attenuators with the VOLTS/DIV switch (S101/S201), the signal can be attenuated for a total range of 1/1 to 1/1000 in 10 steps.

The 1st attenuator directly attenuates the signal received from the input coupling switch and feeds the attenuated signal to the voltage follower. The 2nd attenuator attenuates the low-impedance output signal of the voltage follower and feeds the attenuated signal to the 1st differential cascade amplifier.

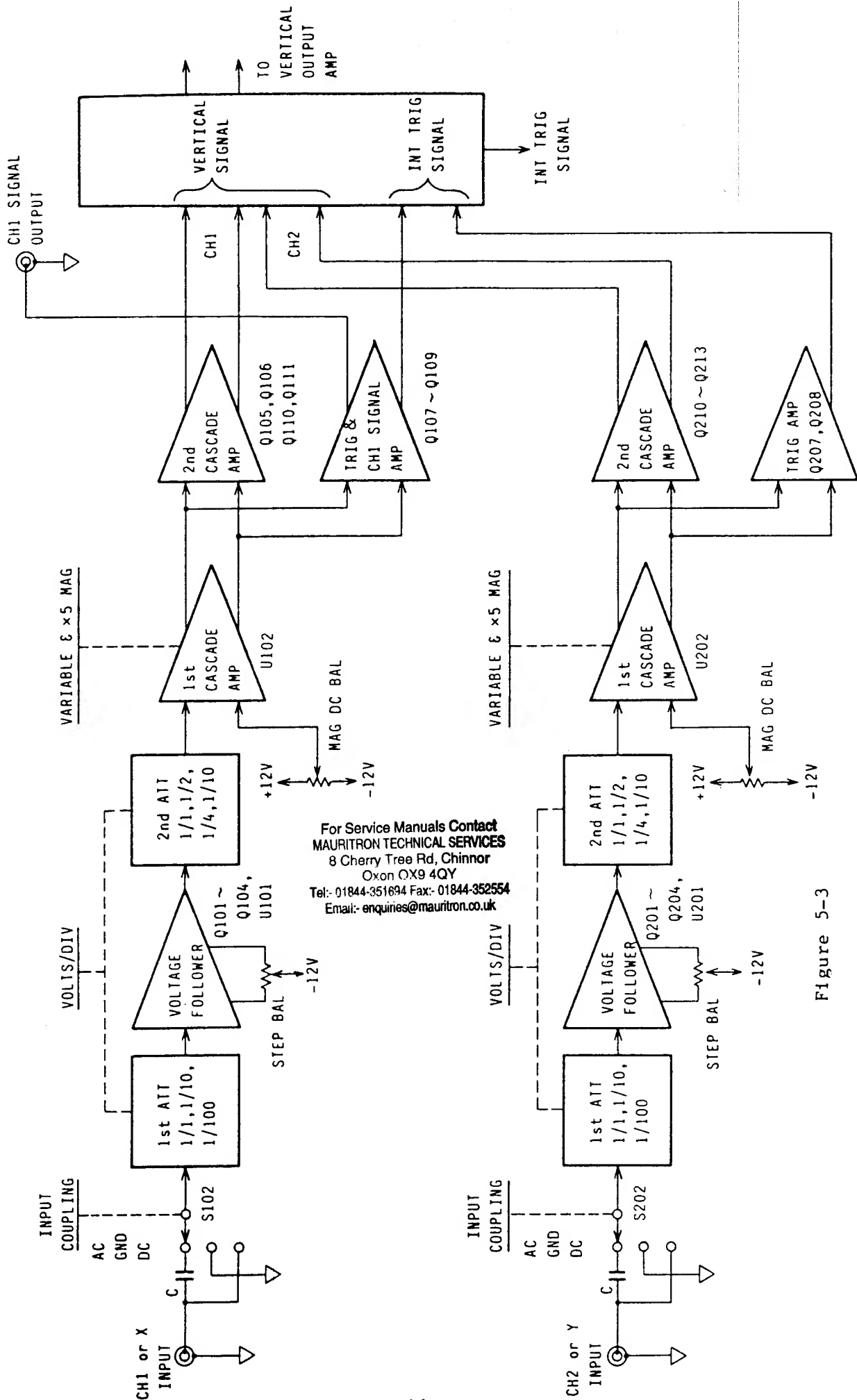

For Service Manuals Contact
MAURITRON TECHNICAL SERVICES
 8 Cherry Tree Rd, Chinnor
 Oxon OX9 4QY
 Tel: 01844-351694 Fax: 01844-352554
 Email: enquiries@mauritron.co.uk

Figure 5-3

- o Impedance converter:

The impedance converter provides with its source follower (Q101/Q201) a high input impedance to prevent the loading effect on the high-impedance attenuator circuit and provides a low output impedance with its emitter follower (CH1 and CH2) to drive the 1st differential cascade amplifier of the next stage. In order to guard against thermal drift, the source follower employs a dual-FET package which houses two thermally-coupled elements for thermal drift compensation and the emitter follower employs two premium-grade thermally-coupled transistors.

- o 1st differential cascade amplifier:

The 1st differential cascade amplifier is comprised of an emitter-connected differential current amplifier (U102-1/2, U202-1/2) and a current-to-voltage converter (U102-2/2, U202-2/2) which converts the differential collector output current of the differential current amplifier into a voltage signal. This amplifier also has the VARIABLE circuit for continuously-variable adjustment of the sensitivity between two adjoining vertical deflection sensitivity ranges selected by the VOLTS/DIV switch and the $\times 5$ MAG switch for magnifying the vertical sensitivity by 5 times to realize the 1 mV/DIV sensitivity.

- o VARIABLE circuit:

The VARIABLE circuit continuously-variably adjusts the vertical sensitivity by shunting with potentiometer RV104/RV204 a part of the collector current amplified by U102-1/2 or U202-1/2. Adjustment (attenuation) can be done with a ratio of 1/2.5 or over.

- o $\times 5$ MAG circuit:

The $\times 5$ MAG function is to increase the vertical sensitivity by 5 times by switching the emitter resistor of the 1st differential cascade amplifier.

o 2nd differential cascade amplifier:

The 2nd differential cascade amplifier (Q105, 106, 110, 111, or Q205, 206, 210 - 213) amplifies the output of the 1st differential cascade amplifier to a sufficient level for driving the vertical switching circuit. The grounded-base stage (Q110, 111/Q209 - 212) of this cascade amplifier has a function of preventing the switching signal of the vertical switching circuit from being returned to the preceding stage and mixed into the trigger signal or the signal of the CH1 signal output amplifier. For the CH2 signal, this amplifier also has a function of inverting its polarity. This polarity inverting function is accomplished by switching with the INV switch the base grounding stages of Q210/213 and Q211/212 to which the collector currents which have been current-amplified by Q205 and Q206 are fed in a crossing manner.

Different from the case of the 1st differential cascade amplifier, the output signal of the 2nd differential cascade amplifier is fed directly in the form of the current signal to the diode gate of the vertical switching circuit. The current signal for vertical positioning of the trace on the CRT screen is added to the output current signal of the 2nd differential cascade amplifier, being controlled by potentiometer RV111/211 of the positioning circuit.

o Trigger signal amplifier (& CH1 signal output amplifier):

This circuit amplifies with its Q107, 108/Q207, 208 the signal picked off from the 2nd differential amplifier, and converts with its Q109 the collector output of Q107 into a low-impedance CH1 output signal which is fed to J-6C. The collector output signal of Q108/Q208 is fed as a trigger signal to the internal trigger signal switching circuit.

5.3 Vertical Switching Circuit

The vertical switching circuit is comprised of a vertical signal switching circuit (diode gate circuit) which electronically switches the vertical signals received from the CH1 and CH2 preamplifiers,

For Service Manuals Contact
MAURITRON TECHNICAL SERVICES
8 Cherry Tree Rd, Chinnor
Oxon OX9 4QY
Tel: 01844-351694 Fax: 01844-352554
Email: enquiries@mauritron.co.uk

an internal trigger signal switching circuit which electronically switches the trigger signals, and a switching logic circuit which controls these switching circuits.

The vertical signal switching circuit is, as shown in Figure 5-3, comprised of a diode gate circuit, an ADD BAL circuit, and a switching buffer circuit which receives the signal from the diode gate circuit.

- o Diode gate circuit:

The diode gate circuit (CR103 - 106, CR203 - 206) selects the CH1 and CH2 signals being controlled by the signal of the switching logic circuit according to the mode selected by the VERT MODE switch (S301).

For example, when the VERT MODE switch is set at CH1, the CH1 control signal becomes the Hi state, and the CH2 and CH3 control signals become Lo state. Consequently the output signal of the CH1 preamplifier is fed through CR103 and CR106 to the switching buffer circuit consisting of Q305 and Q306. The signals of the other channels are fed through respective diodes (CR204/205) to the control circuit. Thus, the signal of CH1 alone is fed to the switching buffer circuit and the signals of the remaining channels are blocked.

- o ADD BAL circuit

When the ADD mode is selected by the VERT MODE switch, the control signals of both CH1 and CH2 become the Hi state, the signals of the CH1 and CH2 preamplifiers are fed through CR103/106 and CR203/206 to the switching buffer circuit, and the two signals are fed as their sum signal to the output circuit. The function of the ADD BAL circuit is to compensate for the DC balance shift caused by the above addition operation, with its ADD BAL control (semi-fixed potentiometer RV301).

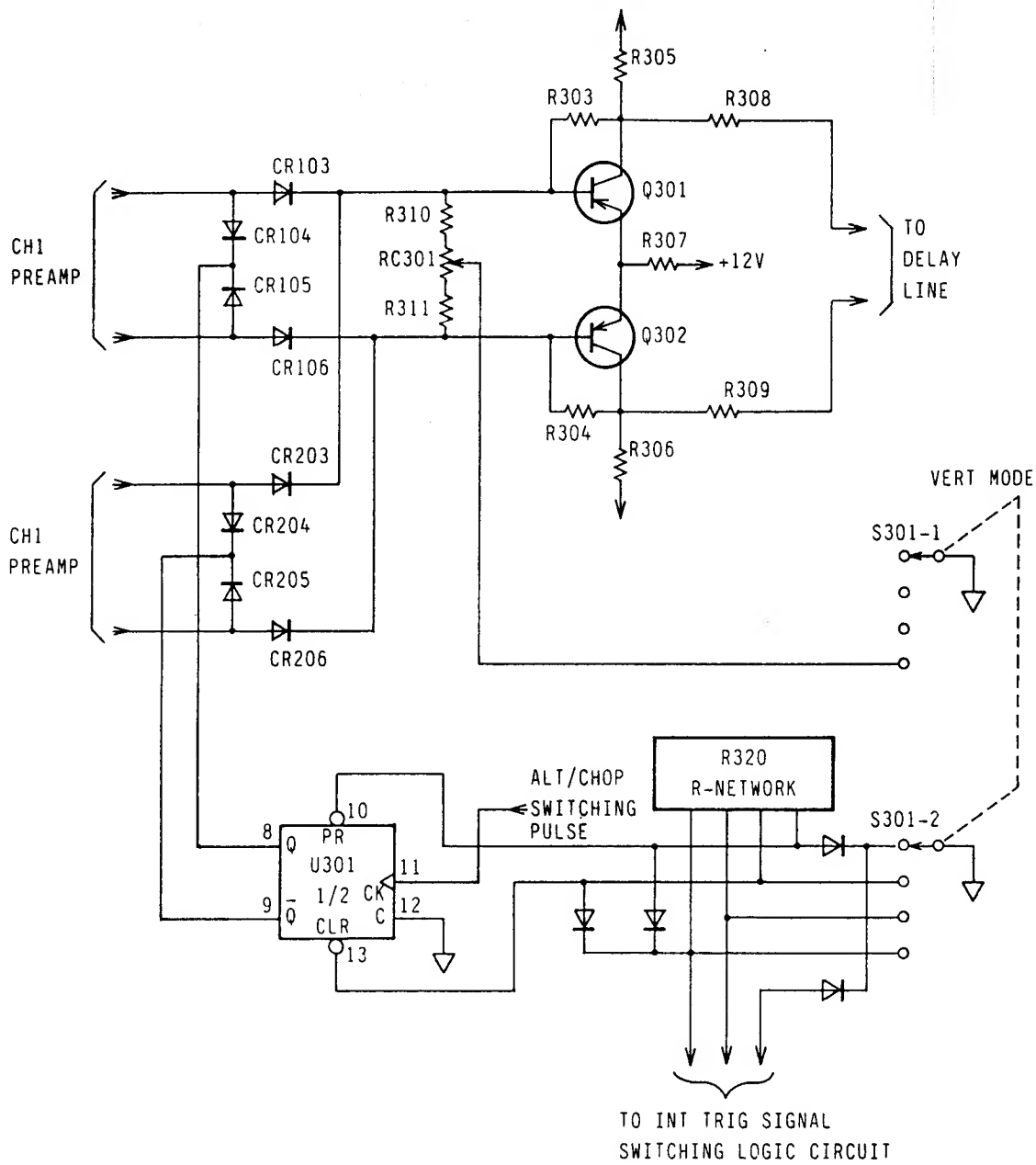

Figure 5-3

For Service Manuals Contact
MAURITRON TECHNICAL SERVICES
 8 Cherry Tree Rd, Chinnor
 Oxon OX9 4QY
 Tel:- 01844-351694 Fax:- 01844-352554
 Email:- enquires@mauritron.co.uk

o Internal trigger signal switching circuit:

The internal trigger signal switching circuit directly controls, with the control signal from the switching logic circuit, the diode gate circuit (CR107, 108, 207, 208) which is similar to the vertical signal switching circuit. The trigger signal which has passed the diode gate circuit is delivered as the internal trigger signal via connector P-7.

o Switching logic circuit:

The switching logic circuit is comprised of a vertical switching logic circuit which controls the vertical signal switching circuit and an internal trigger switching logic circuit which controls the internal trigger signal switching circuit.

The vertical switching logic circuit is comprised of a flip-flops (U301) with preset/clear terminal. Switching of channels can be done by turning on and off the preset/reset terminal of the flip-flop.

The internal trigger switching logic circuit controls the internal trigger signal switching circuit by switching it for the mode selected by the VERT MODE switch and TRIG SOURCE switch. This relationship is shown in the following table.

| TRIG SOURCE VERT MODE | CH1 | CH2 |
|--------------------------|------------------|------------------|
| CH1 | Triggered by CH1 | |
| CH2 | Triggered by CH2 | |
| DUAL | Triggered by CH1 | Triggered by CH2 |
| ADD | Triggered by CH1 | Triggered by CH2 |

For Service Manuals Contact
MAURITRON TECHNICAL SERVICES
 8 Cherry Tree Rd, Chinnor
 Oxon OX9 4QY
 Tel:- 01844-351694 Fax:- 01844-352554
 Email:- enquiries@mauritron.co.uk

- o Switching buffer amplifier:

The vertical signal which has passed the diode gate is fed to the switching buffer amplifier (Q301, 302). The vertical signal amplified by the switching buffer amplifier is fed to the vertical output amplifier via the P-9/J-9 connector and 2-conductor shielded cable.

5.4 Vertical Output Amplifier

The vertical amplifier is comprised of a drive amplifier and a final amplifier. The drive amplifier amplifies the signal received from the switching buffer amplifier and drives the final amplifier. The final amplifier amplifies the signal to a level sufficient for driving the vertical deflection plates of the CRT.

- o Drive amplifier:

The drive amplifier (Q305, 306) is a feedback amplifier, with low output impedance for driving the final amplifier.

- o Final amplifier:

The final amplifier boosts the signal to a level sufficient for driving the vertical deflection plates of the CRT. It is comprised of a pair of feedback-type SEPP amplifiers.

Transistors Q307, 308/Q309, 310 current-amplify the signal to a level sufficient for driving transistors Q312, 313/Q314, 315. The signal which has been voltage-amplified by transistors Q417, 418/Q419, 420 is returned to the input circuit through the negative feedback circuit (R435/R436). The gain in this case is as follows:

$$A_v = \frac{R346}{R388} \quad A_v' = \frac{R347}{R339}$$

Transistors Q311/Q316 are for the dynamic bias circuit which controls the bias current with respect to the repetition frequency of the signal in order to economize current consumption.

5.5 Trigger Generator

The trigger generator is comprised of a trigger pulse generator circuit which produces a trigger pulse signal for driving the sweep generator and an AUTO circuit which produces a free-run signal for automatic sweep operation when the trigger signal is asynchronized or no trigger signal is applied.

The trigger pulse generator circuit of the trigger generator is comprised of a source switch which selects a trigger signal source, a coupling switch which selects a coupling mode in conformity with the nature of the trigger signal source, an impedance converter circuit which converts the high-impedance trigger source signal into a low-impedance signal with which to drive the level comparator circuit which controls the start point (triggered point) of the signal waveform displayed on the CRT screen, a TV synchronization separator circuit which picks off the synchronization signal from the TV video signal, and Schmitt trigger circuits which convert the output signals of the level comparator circuit and TV synchronization signal separator circuit into TTL level signals.

o Source switch:

The source switch (S401) selects the internal trigger signal fed from Q401, the line trigger signal fed from R662, the external trigger signal fed from P-12. The selected signal is fed to the coupling switch.

o Coupling switch:

The coupling switch (S402-1) selects the coupling mode: It selects the DC mode for direct coupling of the signal fed from S401, the AC mode for discarding the DC component, or the HF REJ mode for coupling via a low-pass filter. Switch S402-2 selects ON or OFF of the TV synchronization signal separator circuit which facilitates observation of a TV video signal.

For Service Manuals Contact
MAURITRON TECHNICAL SERVICES
8 Cherry Tree Rd, Chinnor
Oxon OX9 4QY
Tel: 01844-351694 Fax: 01844-352554
Email: enquiries@mauritron.co.uk

o Impedance converter:

The impedance converter is a source follower (Q403) with FET. It converts the trigger signal selected by the source switch and coupling switch into a low-impedance signal, which is fed to drive the level comparator circuit (Q404, Q405).

o Level comparator:

The level comparator is a differential amplifier (Q404, 405), which adjusts the rise up portion (or the fall down portion) of the comparator output signal by applying the trigger source signal (the base signal of Q404) from the impedance converter circuit and applying the comparator level signal (the base signal of Q405) from the LEVEL control potentiometer (RV402-1). In this case, if switch S405 which is linked to the LEVEL control potentiometer is locked, the comparator level signal is applied to the base of Q405 from the level lock circuit and the trigger point is fed at the center amplitude of the trigger source signal.

The level lock circuit amplifies with its error amplifier (Q408, 409) the error signal detected by Q406 and Q407, and feeds back the signal so that the center level of the comparator output signal becomes the Schmitt level of the Schmitt trigger circuit.

It also selects a slope by switching the comparator output with the slope switch (S403-1).

The output signal of the level comparator is fed to the buffer amplifier which operates also as a signal separator circuit.

o Buffer amplifier/TV synchronization signal separator circuit:

This circuit operates either as a buffer amplifier or as a TV synchronization signal separator circuit, being selected by the transistor switching circuit (Q410, 411).

When Q410 is on and Q411 is off, the circuit operates as a buffer amplifier and amplifies the output signal of the level comparator to a level sufficient for driving the Schmitt circuit of the next stage.

When Q410 is off and Q411 is on, the circuit operates as a TV synchronization signal separator circuit and picks off the TV-H synchronization signal, which is pulsewidth-detected into a TV-V synchronization signal by the Schmitt circuit of the next stage.

o TRIG Schmitt circuit:

The TRIG Schmitt circuit is a conventional circuit which generates a hysteresis voltage by applying a feedback signal with R440 to the two stages of NAND gates of 401. The output of the Schmitt circuit drives the A and B SWEEP generators and AUTO circuit.

o AUTO circuit:

The AUTO circuit is comprised of a uni-junction transistor (UJT) circuitry made up by connecting mutually the bases and collectors of a PNP transistor (Q416) and an NPN transistor (Q415). This circuit converts the high-speed pulse output signal of the Schmitt circuit into a DC signal, with which to drive the A sweep generator.

5.6 A and B Sweep Generators

The A sweep generator produces the sawtooth signal for the main sweep (A sweep) of this oscilloscope. The B sweep generator produces the sawtooth signal for magnification in the time axis direction the waveform displayed on the main sweep or for display with a certain time delay (delayed sweep or B sweep).

The A sweep generator consists of the A sweep gate circuit which receives the trigger signal from the trigger generator and produces the sweep gate signal for starting sweeps, the sweep start comparator which maintains stably the sweep start point, the A sawtooth sweep generator which produces a sawtooth wave in conformity with the time constant selected by the TIME/DIV

switch, the sweep length circuit which controls the length of sweeps, the hold off circuit which controls the sweep return period and pause period, and the A sweep gate enable circuit which controls the sweep gate circuit in conformity with the AUTO, NORM or SINGLE mode as selected by the MODE switch for the signals of the above control circuits.

*: The B sweep generator is for the COS5021 only.

o A sweep gate:

The A sweep gate circuit employs a flip-flop TTL IC (U402-1/2) with preset/clear function. The trigger pulse of the trigger generator is applied to the CLOCK (Pin No. 1) terminal, the enable signal of the A sweep gate enable circuit to the CLEAR (Pin No. 15) terminal, and the enable signal and AUTO signal of the AUTO circuit to the PRESET (Pin No. 4) terminal through the NOR gate circuit. The Q (Pin No. 5) terminal output is applied as the unblanking signal to the Z-axis amplifier and the \bar{Q} (Pin No. 6) terminal output is fed to the sweep start comparator circuit and becomes the A sweep gate signal. Even when no trigger pulse signal is applied to the CLOCK terminal, the \bar{Q} output can be made the low state with the AUTO signal of the PRESET terminal so that the A sweep gate signal is generated and the circuit operates in the free-run mode.

o Sweep start comparator:

The sweep start comparator (Q419, 420) is a differential amplifier which lets the sweep gate signal pass and maintains constant the sweep start level. A start reference level identical with the B sweep start level is applied to one of the inputs, the Miller integrator output signal is applied to the other input, and the difference between the two signals is compensated for.

For Service Manuals Contact
MAURITRON TECHNICAL SERVICES
8 Cherry Tree Rd, Chinnor
Oxon OX9 4QY
Tel: 01844-351694 Fax: 01844-352554
Email: enquiries@mauritron.co.uk

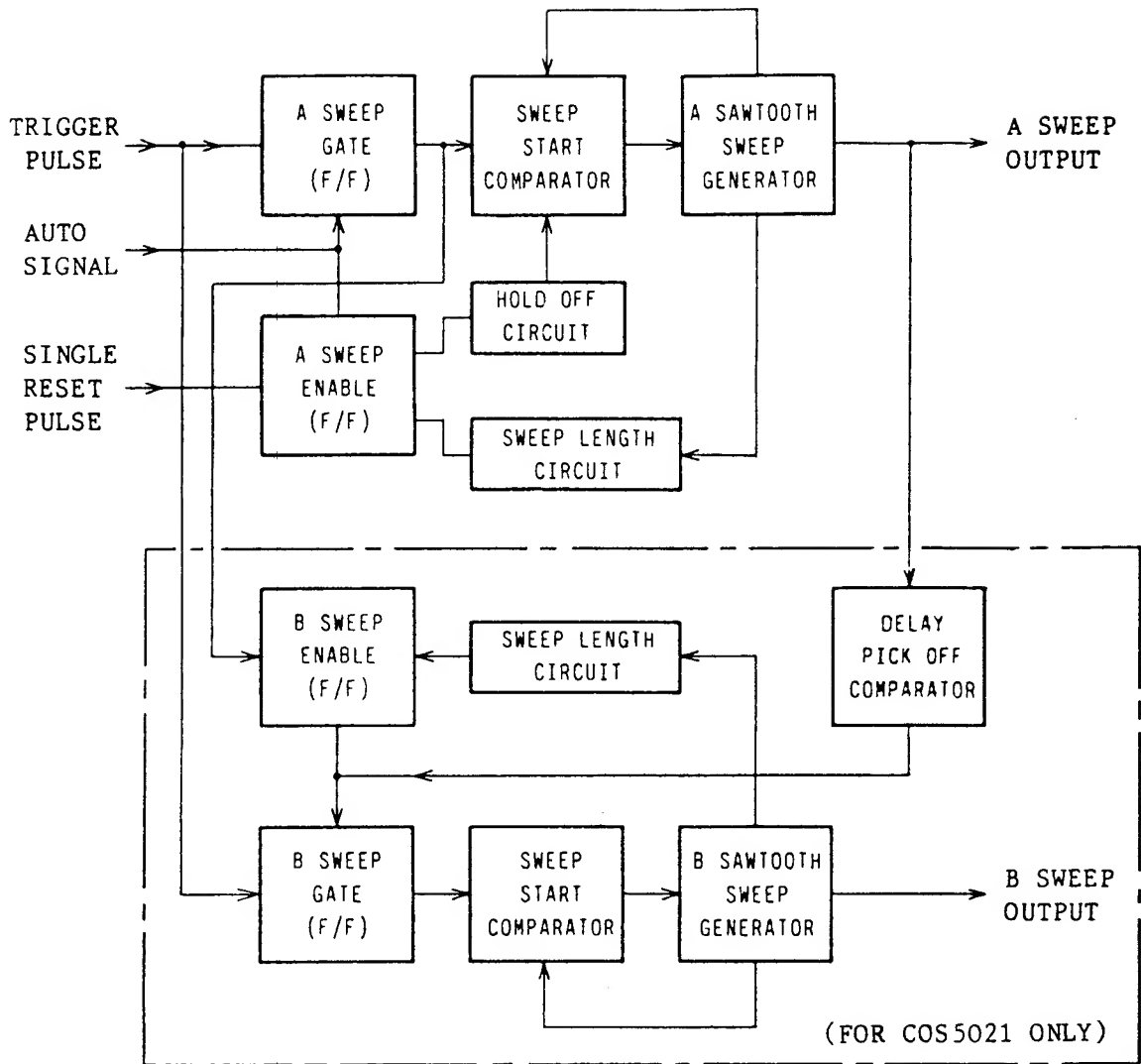

Figure 5-4

o A sawtooth generator:

The A sawtooth generator is comprised of a gate transistor amplifier, a Miller integrator, an integration time constant switching circuit, and a TIME/DIV switch which controls the switching circuit. The gate transistor amplifier (Q423) controls the Miller integrator circuit in such manner that the start level control signal and sweep gate signal of the sweep start comparator do not affect the integration time constant. The Miller integrator (Q425) produces a sawtooth signal with the time constant selected by the integration time constant selector circuit. The integration time constant selector circuit selects integration capacitor C459/C460 with Q426. For integration current, resistor array (R491, 492, 493) is directly selected by the TIME/DIV switch (S406-1).

For Service Manuals Contact
MAURITRON TECHNICAL SERVICES
8 Cherry Tree Rd, Chinnor
Oxon OX9 4QY
Tel:- 01844-351694 Fax:- 01844-352554
Email:- enquiries@mauritron.co.uk

o Sweep length circuit:

This circuit divides the A sweep generator output by R461/R462 and shapes the waveform with Q418 to obtain a sweep length signal.

o Holdoff circuit:

The holdoff circuit generates a holdoff (pause) time signal proportional to the sweep time by producing a triangular wave with an integrator circuit and making use of the rise time of the triangular wave. The integrator, with its Q421, selects the time constant in accordance with the integration output voltage in order to cover a wide time range. The output signal of the integrator circuit is shaped by Q417 into a holdoff signal.

o A sweep gate enable circuit:

The A sweep gate enable circuit employs the flip-flop IC (U402-2/2) which makes up a pair with the A sweep gate circuit. The holdoff signal is applied to the PRESET (Pin No. 10) terminal, the length signal is applied to the CLEAR (Pin No. 14) terminal, and the enable signal is delivered from the Q (Pin No. 9) terminal. This enable signal presets or clears the A sweep gate circuit.

When in the NORM sweep mode, the output signal of the AUTO circuit is blocked and, if no trigger signal is applied, the circuit is in the ready state. When in the SINGLE sweep mode, the holdoff circuit remains idle and a one-shot sweep is effected by the reset signal applied from the CLOCK (Pin No. 13) terminal.

This paragraph is applicable to the COS5021 only: The basic structure of the B sweep generator is identical with that of the A sweep generator. It consists of the B sweep gate, sweep start comparator, B sawtooth generator, sweep length circuit, B sweep enable circuit, and delay pickoff comparator. The B sweep generator requires no holdoff circuit because it operates only during the period the A sweep generator is in the sweep operation. Instead of the holdoff signal, the A sweep gate signal sets the B sweep enable circuit to the enable state.

o Delay pickoff comparator:

The delay pickoff comparator (Q702 - 704) employs a differential comparator to obtain a certain time relationship as set by the delay time multiplication potentiometer (RV701) with respect to the A sweep signal. The comparator compares the A sweep output signal (sawtooth waveform) with the voltage set by RV701, generates a delayed sweep start signal, and sets the B sweep gate circuit to start the B sweep signal. When in the B TRIG'D mode, the B sweep gate circuit is not set directly with this delayed sweep start signal but the PRESET (Pin No. 4) terminal is set to the high state and the B sweep signal is started as driven by the trigger pulse of the trigger generator.

5.7 Horizontal Switching Circuit

The horizontal switching circuit is comprised of a switching buffer circuit which prevents switching distortion from being sent to the sweep circuit of the preceding stage, a display switching circuit which electronically switches the A and B sweep signals and CH1 HOR (X) signal, and a display switch (S702) to control these circuits. (The display switch is for the COS5041 only.)

- o Switching buffer circuit:

The switching buffer circuit is of a grounded-base-type amplifier. Transistor Q430 is for buffer-amplification of the A sweep signal, transistor Q712 for the B sweep signal.

- o Display switching circuit:

The display switching circuit, with its analog signal multiplexer IC (U404), selects the A and B sweep signals and CH1 HOR (X) signal.

5.8 Horizontal Output Amplifier

The horizontal output amplifier consists of a drive amplifier which selects between NORM and $\times 10$ MAG mode for the horizontal signal received from the horizontal switching circuit and drives the output amplifier, and an output amplifier which drives the horizontal deflection plates of the CRT.

- o Drive amplifier:

The drive amplifier (Q501 - 504) converts the horizontal signal received from the horizontal switching circuit into a differential signal, with which to drive the output amplifier. With Q501 and 502, gain of the differential amplifier can be multiplied by a factor of 10 for the $\times 10$ MAG function.

- o Output amplifier:

The output amplifier (Q505 - 512) is comprised of feedback-type SEPP amplifiers symmetrical for right and left which provide sufficient speed and output voltage for driving the horizontal deflection plates of the CRT. The signal current-amplified by Q505/Q506 is converted into a voltage signal by Q507 - Q512 to obtain a sufficiently high gain and a sufficiently low output impedance. By means of negative feedback resistor R518/R519 a stable gain and wide and flat frequency response are attained.

5.9 Z-axis Amplifier

The Z-axis amplifier is comprised of an input circuit and an output amplifier. The input circuit merges the unblanking signals of the A and B sweep generators, the external intensity modulation signal applied through the Z-axis input terminal, the B intensity control signal, and the overall intensity control signal. The output amplifier amplifies the merged signal into a sufficient level for driving the G1 grid of CRT.

o Input circuit:

The input circuit merges the unblanking signals of the A and B sweep generators, the chopped blanking signal, the external intensity modulation signal applied via the X-axis input terminal, and the overall intensity control signal. The resultant compound signal is fed to the output amplifier.

o Output amplifier:

The output amplifier amplifies the above compound signal to several tens volts. It is of a feedback-type SRPP circuit (Q654, 656, 658). This amplifier also generates (with its Q655, 657, 659) a linear focus signal which is in the inverted phase of the unblanking signal. The amplified unblanking output signal and linear focus signal are fed to the G1 and P1 of the cathode-ray tube through the CRT circuit to drive the intensity and focus of the displayed waveform.

5.10 CRT Control Circuit

The CRT control circuit is comprised of a DC regeneration circuit which converts the linear focus signal and the unblanking output signal of the Z-axis amplifier into the operating-voltage signals of the CRT in order to be applied to the focus electrode and G1 electrode of the CRT, semi-fixed potentiometers ASTIG (RV652), GEOMETRY and SUB-FOCUS (RV651), a trace rotation circuit for adjusting the trace direction in parallel with the horizontal graticule lines, and an illumination circuit for illuminating the graticule.

o DC regeneration circuit:

The DC regeneration circuit converts the linear focus signal and unblanking signal of several tens to several hundreds volts into AC signals with the switching signal of the DC-DC converter circuit, and then converts them back into DC signals with respect to the cathode voltage and focus reference voltage of the sub-focus potentiometer in order to provide a focus signal and an unblanking signal of the operating voltages of the CRT.

5.11 HV Regulator (High Voltage Generator)

The high voltage generator produces an acceleration voltage (-2100 V) applied to the CRT cathode. The circuitry is a DC-DC converter with blocking oscillator (Q651), with resonance of the secondary coil winding. The high voltage of approximately 4200 Vp-p (frequency approximately 30 kHz) generated by the blocking oscillator and it is half-wave rectified into a negative voltage of -2100 V.

This DC-DC converter feeds the negative voltage via a high resistance circuit (R661, R662) to the control circuit (U651) to obtain a stabilized acceleration voltage. It also is fed through a capacitor-coupling circuit to the DC regeneration circuit in order to be used as the switching signal.

5.12 Power Supply Circuit

The power supply circuit steps up or down with its power transformer the AC line voltage into various voltages and rectifies them to DC supply voltages for the various circuits of the oscilloscope. The primary winding of the power transformer is of a split type, in order that the oscilloscope can be operated on various AC line voltages by connecting the transformer taps in series or parallel as required by means of the line voltage selector plug (P-47). Regarding the secondary circuit, the transformer has one 6.3 V winding for the CRT heater and two windings of different voltages for different circuits of the CRT. The AC voltages of the two windings are rectified and supplied as non-regulated +16 V power and regulated +160 V, +12 V, +5 V, and -12 V powers.

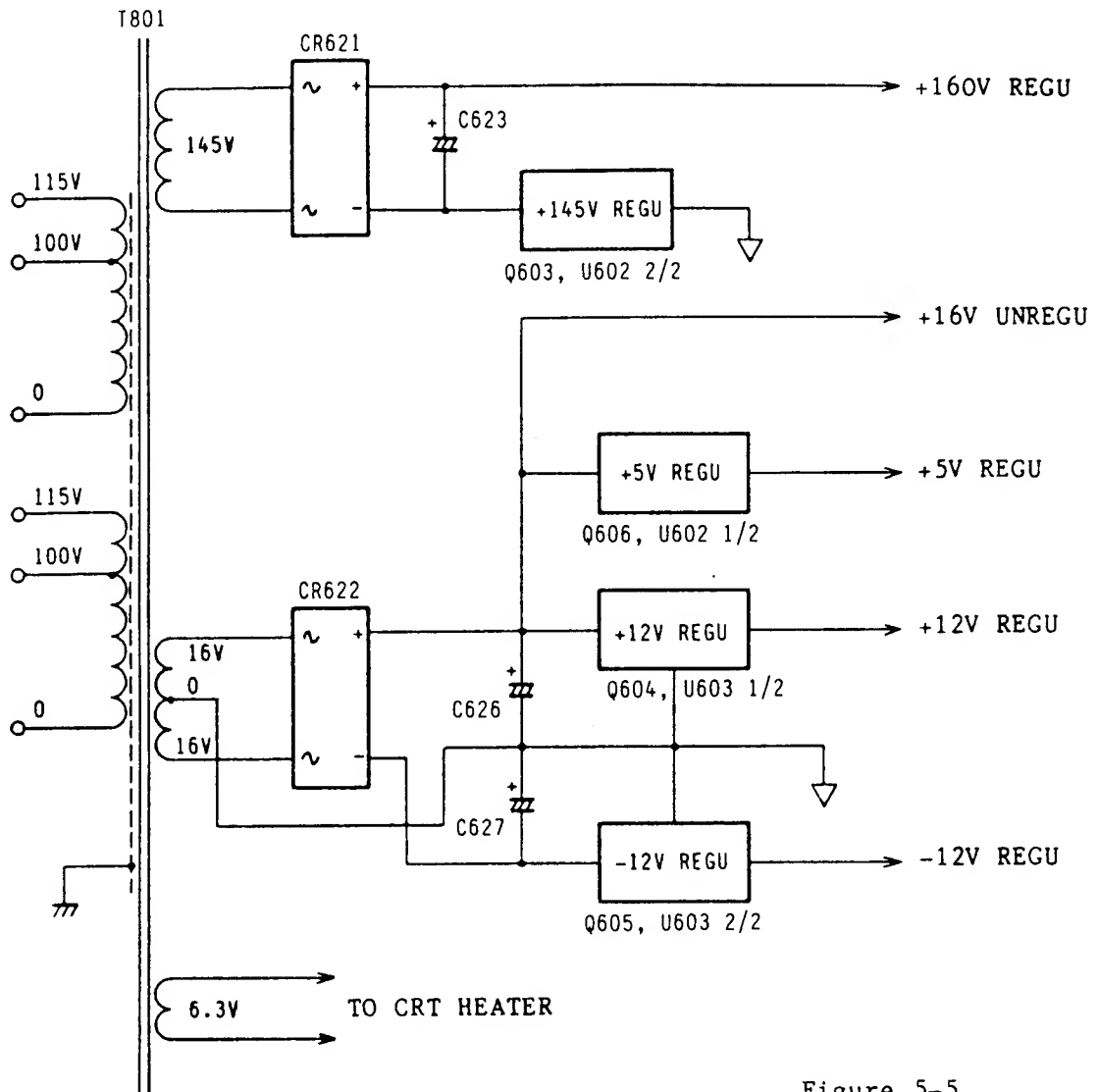

Figure 5-5

5.13 Calibrator Circuit

The calibrator circuit provides square-wave calibration voltage signal of 2 V_{p-p} which is used for calibration of the probe and the amplifiers when they are operated in the non-calibrated mode. The voltage accuracy of the calibration signals is 2% or better. The calibration signal is produced by generating a signal with the multivibrator of CMOS IC (U1601 1/4, 2/4), shaping the waveform with the Schmitt circuit of CMOS IC (U1601 3/4, 4/4), and dividing the voltage signal with resistors.

6. CALIBRATION

6.1 General

After the oscilloscope has been used for a period of time, it should be calibrated. Although calibration of overall performances is recommended, partial calibration may serve the purpose as that the time axis alone is calibrated when the time measuring accuracy is especially important or that the vertical axis alone is calibrated when the vertical sensitivity accuracy is of prime importance. After the oscilloscope has been repaired, overall calibration is suggested although it depends on the type of repair. For accurate calibration service, contact your Kikusui agent.

6.2 Removing the Case

To remove the case, remove the nine screws (Figure 6-1) and detach the top panel upward and the bottom panel downward.

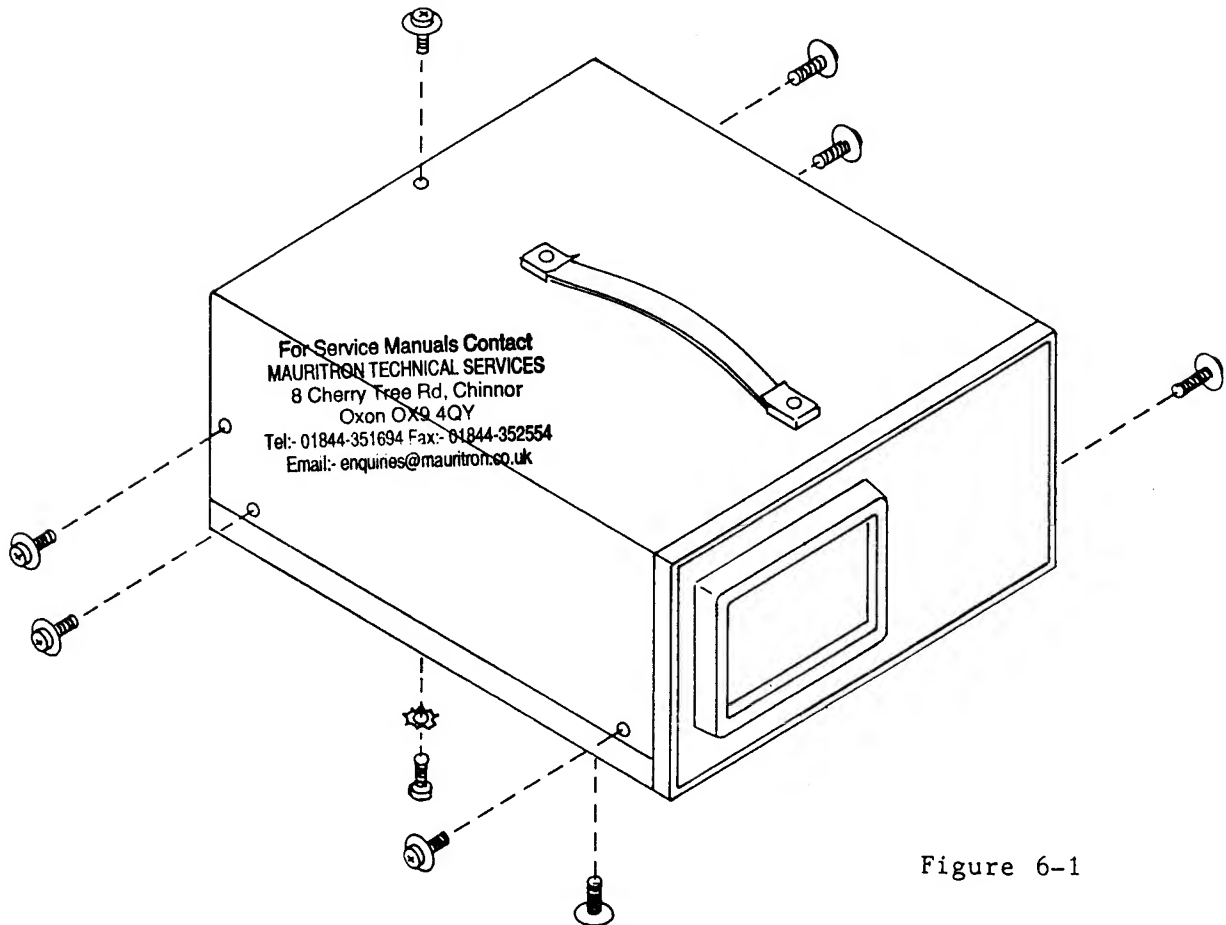
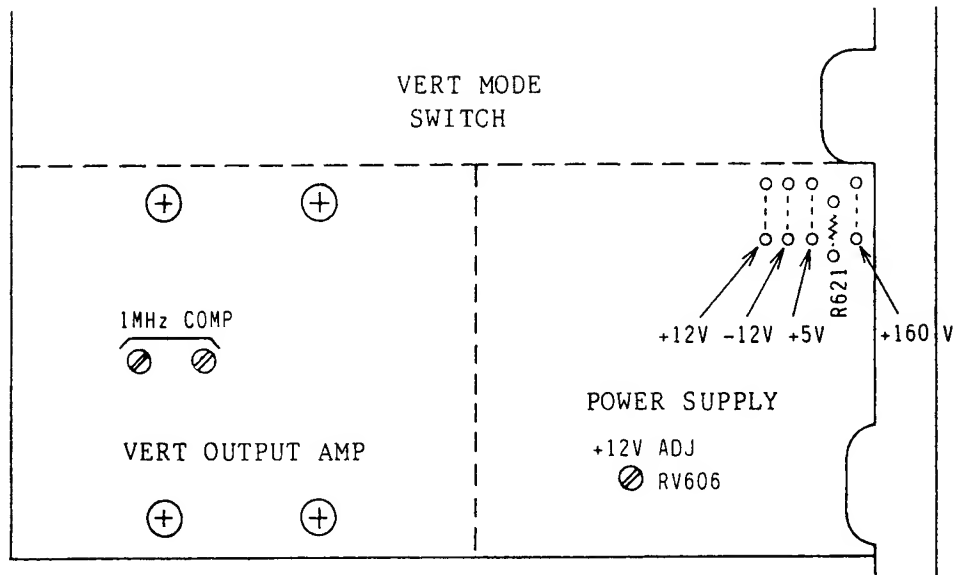

Figure 6-1

6.3 Check and Adjustment of DC Supply Voltages

Before calibrating the oscilloscope, its DC supply voltages should be checked and adjusted. Check and adjust the +12V supply voltage first and the other supply voltages next. The supply voltages are shown in the following table and the check and adjustment points are indicated in Figure 6-2.

| Nominal voltage | Tolerance | Check and adjustment points |
|-----------------|--------------------|--------------------------------|
| +5 V | +4.75 to +5.25 V | RV606 (Figure 6-2) |
| +12 V | +11.95 to +12.05 V | |
| -12 V | -11.80 to -12.20 V | |
| +160 V | +155 to +165 V | P36, Pin No. 3 (Figure 6-5) |
| -2100 V | -2050 to -2150 V | |



(Bottom)

Figure 6-2 A1 printed circuit board

For voltage check, measure the voltage between check point and ground using precision digital voltmeter. The +12V supply must be especially carefully adjusted because it provides a reference for other supplies. To measure the -2100V supply of which internal impedance is high, use a voltmeter which has a sufficiently high input impedance (10 M Ω or over).

Because adjustments of supply voltages largely affect vertical sensitivity and horizontal sweep time, the oscilloscope must be re-calibrated as explained in the subsequent paragraphs.

6.4 Adjustment of CRT Circuits

Some adjustments of the CRT circuits directly affect the CRT deflection sensitivity as is the case of "Check and Adjustment of DC Supply Voltages" of the preceding section.

o Adjustment of SUB INTEN:

This control is for adjusting the trace intensity and the operating position of the INTEN knob (4).

- (1) Set the TIME/DIV switch (30) at 1 mS and display a single-line horizontal trace on the screen.
- (2) Set the white mark of the INTEN knob at the 10 o'clock position and so adjust the SUB INTEN control (Figure 6-5, RV653) that the trace is displayed on the screen with a barely discernible intensity.

o Adjustment of SUB-FOCUS:

This control is for adjusting the control range position of the FOCUS knob (6). With the FOCUS knob set with its white dot positioned upright (noon position), so adjust the SUB-FOCUS control (Figure 6-5, RV651) that the best focus is obtained.

For Service Manuals Contact
MAURITRON TECHNICAL SERVICES
8 Cherry Tree Rd, Chinnor
Oxon OX9 4QY
Tel:- 01844-251694 Fax:- 01844-352554
Email:- enquiries@mauritron.co.uk

o Adjustment of ASTIG:

This control is for focus adjustment of the electron lens of the CRT.

- (1) Set the TIME/DIV switch (30) to the

| | |
|-----|---------|
| X-Y | EXT HOR |
|-----|---------|

 position and display the beam spot in the center of the CRT screen with the POSITION controls.
- (2) Turn the FOCUS control (6) to an appropriate position and then adjust the ASTIG control (Figure 6-5, RV652) so that the shape of the displayed beam spot becomes as true circle as possible.

6.5 Adjustment of Vertical Axis

o Adjustment of STEP BAL:

This control is for minimizing the shift of trace when the VOLTS/DIV switch (12) or (16) is turned from the 5 mV position to the 10 mV position.

- (1) Set the AC-GND-DC switch (10) or (19) and display the trace on the CRT screen.
- (2) Turning the VOLTS/DIV switch between 5 mV and 10 mV positions, so adjust the STEP BAL control (Figure 6-6, RV101 or RV201) that the shift of trace becomes minimum.

o Adjustment of ×5 MAG BAL:

This control is for minimizing the shift of trace when the ×5 MAG switch (13) or (17) is changed.

- (1) Set the AC-GND-DC switch (10) or (19) in the GND state and display a trace on the screen.
- (2) Turning on and off the ×5 MAG switch, so adjust the MAG DC BAL control (Figure 6-6, RV112 or RV212) that the shift of trace becomes minimum.

o Adjustment of VAR DC BAL:

This control is for minimizing the shift of the trace when the VARIABLE KNOB (13) or (17) is turned.

- (1) Set the AC-GND-DC switch (10) or (19) in the GND state and display the trace on the CRT screen.
- (2) Turning the VARIABLE knob, so adjust the VAR DC BAL control (Figure 6-6, RV105 or RV205) that the shift of the trace becomes minimum.

o Sensitivity calibration of CH1 and CH2:

Calibrate the sensitivity of the vertical amplifier to the value indicated by the VOLTS/DIV switch (12) or (16). For this adjustment, use a square wave generator with an output voltage setting accuracy of 0.3% or better, at 1 kHz.

- (1) Set the signal generator output at 50 mVp-p and apply the signal to the vertical input terminal (11) or (18).
- (2) Set the VARIABLE knob (13) or (17) at the CAL'D position and set the VOLTS/DIV switch at the 10 mV range.
- (3) So adjust the CH1 or CH2 GAIN control (Figure 6-6, RV110 or RV210) that the amplitude of the displayed waveform becomes 5 DIV.

By the above procedure, other ranges also are calibrated to an accuracy of $\pm 3\%$ or better.

o Sensitivity calibration of $\times 5$ MAG:

In a similar manner as for sensitivity calibration of CH1 and CH2, calibrate the sensitivity for the $\times 5$ MAG function.

- (1) Set the signal generator output at 10 mVp-p and apply the signal to the vertical input terminals (11) and (18).

- (2) Set the VARIABLE knob (13) or (17) at the CAL'D position, set the VOLTS/DIV switch (12) or (16) at the 10 mV range, and pull out the CH1 ×5 MAG switch (13) or (17).
- (3) So adjust the CH1 or CH2 GAIN control (Figure 6-6, RV102 or RV202) that the amplitude of the displayed waveform becomes 5 DIV.

By the above procedure, other ranges also are calibrated to an accuracy of ±5% or better.

o Adjustment of ADD BAL:

With both CH1 and CH2 channels operating in a single-line horizontal trace state at the center of the screen, so adjust this control that the traces do not shift even when the VERT MODE switch is changed to the ADD mode.

- (1) Set the AC-GND-DC switches (10) and (19) in the GND state and display the traces of the two channels overlapped at the center of the screen.
- (2) Change the VERT MODE switch to the ADD state and so adjust the ADD BAL control (Figure 6-6, RV301) that the traces are positioned at the center of the screen.

o Adjustment of square wave characteristics of vertical amplifiers:

This adjustment is to adjust the square wave characteristics of the vertical amplifiers and to make their frequency response flat. This adjustment should be done at a range which does not use the input attenuator (10 mV/DIV range), using a square wave of 1 MHz.

Adjustment should be done using a quality square wave with a rise time of 1.0 nsec or faster, in the order of middle and high ranges, repeating adjustment for a few times.

For Service Manuals Contact
MAURITRON TECHNICAL SERVICES
8 Cherry Tree Rd, Chinnor
Oxon OX9 4QY
Tel: 01844-351694 Fax: 01844-352554
Email: enquiries@mauritron.co.uk

(1) Adjustment for middle frequency range:

Set the VOLTS/DIV switch at 10 mV/DIV and the TIME/DIV switch at 20 μ S/DIV. Apply to the vertical input terminal a square wave of 1 MHz and so adjust the signal generator output that the waveform is displayed with an amplitude of 6 DIV.

Then, so that the waveform becomes as shown in Figure 6-3 (b), adjust RV302 and C331 (Figure 6-6) first and RV109 and C171 (RV209 or C271 for CH2) next.

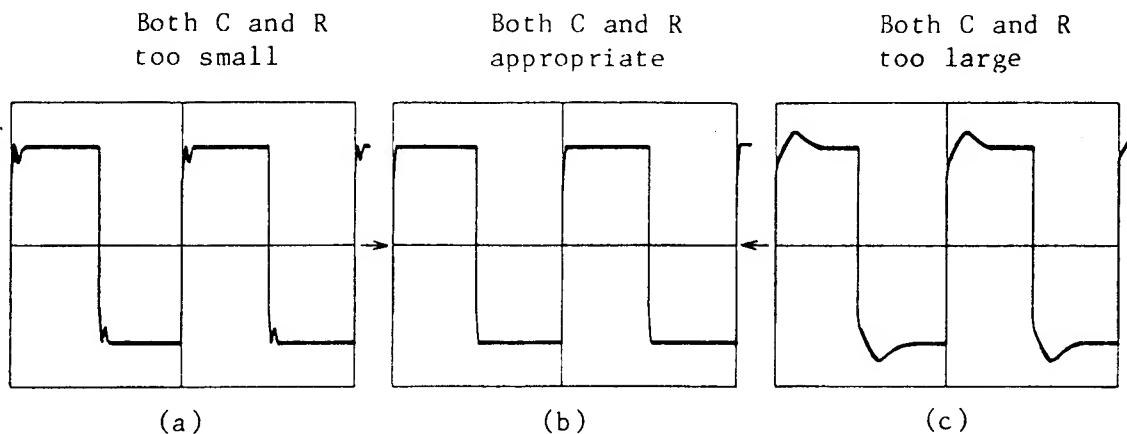

Figure 6-3

(2) Adjustment for high frequency range:

This adjustment is to make still more sharp the leading edge and reduce ringing at the leading edge of the pulse waveform which has been adjusted in step (1).

For this adjustment, adjust CH1 and CH2 to the same characteristics.

Change the TIME/DIV switch to the 0.2 μ S/DIV position and expand the front edge of the pulse waveform which has been adjusted in step (1) "Adjustment for middle frequency range." Next, adjust RV103 and C131 (RV203 and C231 in the case of CH2) so that the leading edge of the pulse waveform becomes sharp.

Repeat the above adjustment so that flat square wave characteristics with sharp leading edge is obtained and the difference between CH1 and CH2 becomes minimum.

After the above adjustment is done, check again that the frequency response characteristics of both channels are satisfactory.

o Adjustment of input ATT of CH1 and CH2:

The VOLTS/DIV switch selects the oscilloscope sensitivity by switching the attenuator circuit consisting of the 1st attenuator (1/1, 1/10, 1/100 steps) and the 2nd attenuator (1/1, 1/2, 1/4, 1/10 steps). This procedure is for phase compensation and input capacitance adjustment of the attenuators. Adjustments should be done in the order of phase compensation and input capacitance adjustment.

Use a square wave signal generator which provides a quality square wave of rise time 1 μ sec or faster, without sags or overshoots. Apply the signal for each of the ranges (0.1 V, 1 V) and display a waveform with an amplitude of 6 DIV. So adjust the phase compensation capacitors shown in the following table (see Figure 6-6) that an ideal waveform is displayed. Next, connect a low-capacitance C-meter to the input terminal and so adjust the input-capacitance compensation capacitor that the input capacitance at each range becomes 25 pF \pm 2 pF.

| Compensation capacitor Range | CH1 | | CH2 | |
|---------------------------------|--------------------|-----------------|--------------------|-----------------|
| | Phase compensation | Input capacitor | Phase compensation | Input capacitor |
| 0.1 V (1/10) | C103 | C102 | C203 | C202 |
| 1 V (1/100) | C106 | C105 | C206 | C205 |

For Service Manuals Contact
MAURITRON TECHNICAL SERVICES
 8 Cherry Tree Rd, Chinnor
 Oxon OX9 4QY
 Tel: 01844-351694 Fax: 01844-352554
 Email: enquiries@mauritron.co.uk

o Adjustment of CH1 SIGNAL OUTPUT DC OFFSET:

* This adjustment must be made after "Adjustment of CH1 TRIG OFFSET" of Section 6.6 has been done.

This adjustment is to make zero the DC offset of the CH1 signal output with the DC OFFSET control.

- (1) Apply the CH1 signal output to the CH2 input terminal using a coaxial cable.
- (2) Display the CH2 input signal on the screen and set the VOLTS/DIV switch at the 10 mV range.
- (3) Changing the CH2 input coupling switch between GND and DC, so adjust the CH1 SIGNAL DC OFFSET control RV108 (Figure 6-6) that shift of the trace becomes zero.

6.6 Adjustment of Trigger Circuit

o Adjustment of CH1 TRIG DC OFFSET:

This adjustment is for offsetting to zero the DC-component displacement of the CH1 internal trigger output.

- (1) Apply a sinusoidal signal of approximately 1 kHz to the CH1 input terminal and set the AC-GND-DC switch at AC.
- (2) Set the VERT MODE switch at CH1, set the INT TRIG switch at CH1 or ALT, and display the signal with an amplitude of 8 DIV on the screen.
- (3) Set the COUPLING switch at AC and so adjust the LEVEL knob that the trigger point is brought to the center of the displayed waveform amplitude.
- (4) Change the COUPLING switch to DC and so adjust the CH1 TRIG & X-AXIS DC OFFSET (Figure 6-6, RV107) that the trigger point is brought to the center of the displayed waveform amplitude.

o Adjustment of CH2 TRIG DC OFFSET:

This adjustment is for offsetting to zero the DC-component displacement of the CH2 internal trigger output.

For this adjustment, adjust CH2 TRIG DC OFFSET (Figure 6-6, RV207) in a similar manner as is the case of "Adjustment of CH1 TRIG DC OFFSET."

6.7 Adjustment of Time Base

o Calibration of A sweep time:

This adjustment is for calibrating the sweep time to the values indicated by the TIME/DIV switch (30). For this adjustment, use time marker signals of accurate time intervals of 1 msec and 1 µsec or use signals of accurate frequencies of 1 kHz and 1 MHz.

- (1) Apply to the vertical input terminal a time marker signal of 1 msec or sinusoidal wave signal of 1 kHz and set the TIME/DIV switch (30) at 1 mS.
- (2) So adjust the 1 mS CAL (Figure 6-5, RV405) that the displayed signal waveform conforms with scale divisions of the graticule.
- (3) Next, change the input signal to a 1-µsec time marker signal or a 1-MHz repetitive frequency signal and change the TIME/DIV switch indication to 1 µS.
- (4) So adjust RV404 (Figure 6-5) that the displayed signal waveform conform with scale divisions of the graticule.

When the above calibration is complete, the sweep speeds of the remaining ranges of the TIME/DIV switch (30) also are calibrated to an accuracy of ±2% or better.

For Service Manuals Contact
MAURITRON TECHNICAL SERVICES
8 Cherry Tree Rd, Chinnor
Oxon OX9 4QY
Tel:- 01844-351694 Fax:- 01844-352554
Email:- enquiries@mauritron.co.uk

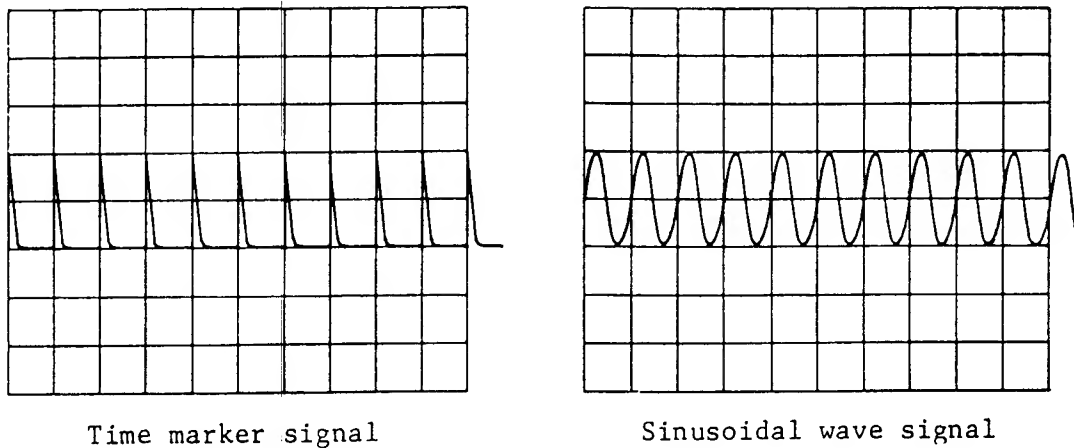

Figure 6-4

- o Calibration of B sweep time (for COS5021 only):

Calibrate the sweep time to the indicated values of the TIME/DIV switch (33). Adjust $1\mu\text{S}$ (Figure 6-5, RV703) in a similar manner as that for the case of "Calibration of A sweep time."

- o Adjustment of sweep start points (for COS5021 only):

This adjustment is for aligning the start points of the A and B sweeps.

- (1) Set the TIME/DIV switches (30) and (33) at 0.5mS, set the DISPLAY switch (29) at ALT, and display the A trace on the screen.
- (2) So adjust the horizontal POSITION knob (32) that the start point of the A trace is brought to the left hand end of the graticule.
- (3) Next, with the B SWEEP START POSITION control (Figure 6-5, RV702), bring the start point of the B trace to the left hand end of the graticule.

For Service Manuals Contact
 MAURITRON TECHNICAL SERVICES
 8 Cherry Tree Rd, Chinnor
 Oxon OX9 4QY
 Tel: 01844-351694 Fax: 01844-352554
 Email: enquiries@mauritron.co.uk

6.8 Adjustment of Horizontal Axes (X-axis)

o Calibration of horizontal sensitivity:

This adjustment is for calibration of the X-axis sensitivity for X-Y operation.

After this adjustment is done, "Adjustment of CH1 SIGNAL OUTPUT DC OFFSET" of Section 6.5 and "Adjustment of CH1 TRIG DC OFFSET" of Section 6.6 must be done.

- (1) Set at 100 mVp-p the output of the signal generator used for "Calibration of sensitivity" of Section 6.5, and apply the output to the CH1 (X) input terminal (11).
- (2) Set the TIME/DIV switch (30) at X-Y EXT HOR, the SOURCE switch (26) at X-Y, the COUPLING switch (25) at DC, and the VERT MODE switch (14) at X-Y.
- (3) So adjust the X-GAIN control (Figure 6-6, RV106) that the horizontal length of the trace becomes 10 DIV.

o Adjustment of X-Y POSITION ADJ:

This adjustment is for adjusting the positional relationship for the ↔ POSITION control when operation is switched between the NORM sweep mode and the X-Y EXT HOR mode.

- (1) Set the TIME/DIV switch (30) at 1 mS/DIV. Align the start point of the sweep with the left hand end of the CRT graticule with the ↔ POSITION control (32).
- (2) Change the TIME/DIV switch (30) to the X-Y EXT HOR to select the X-Y mode.
- (3) So adjust the X-AXIS DC OFFSET control (Figure 6-5, RV401) that the beam spot is positioned at the center of the CRT graticule.

For Service Manuals Contact
MAURITRON TECHNICAL SERVICES
8 Cherry Tree Rd, Chinnor
Oxon OX9 4QY
Tel:- 01844-351694 Fax:- 01844-352554
Email:- enquiries@mauritron.co.uk

LOWER PRINTED
CIRCUIT BOARD

Figure 6-6

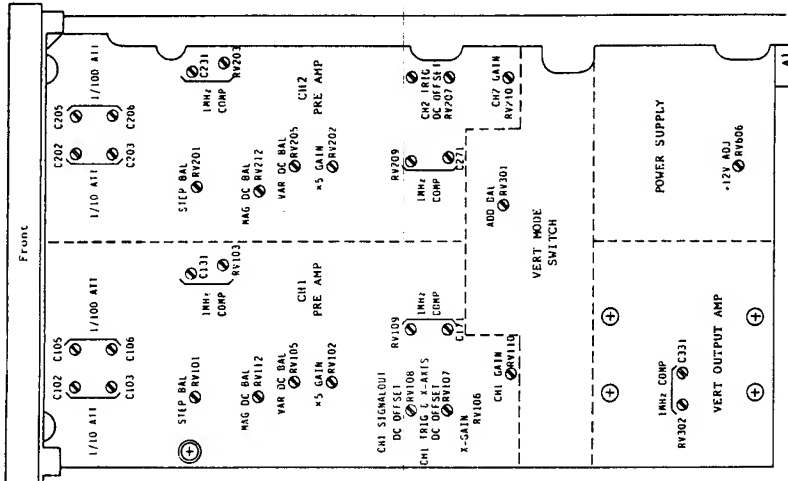

UPPER PRINTED
CIRCUIT BOARD

Figure 6-5

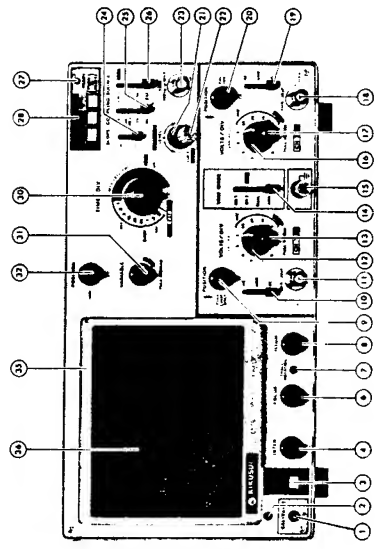
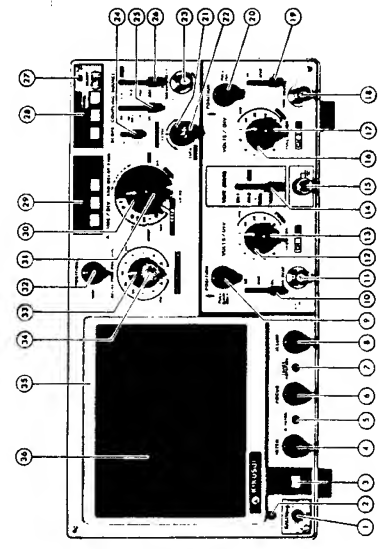
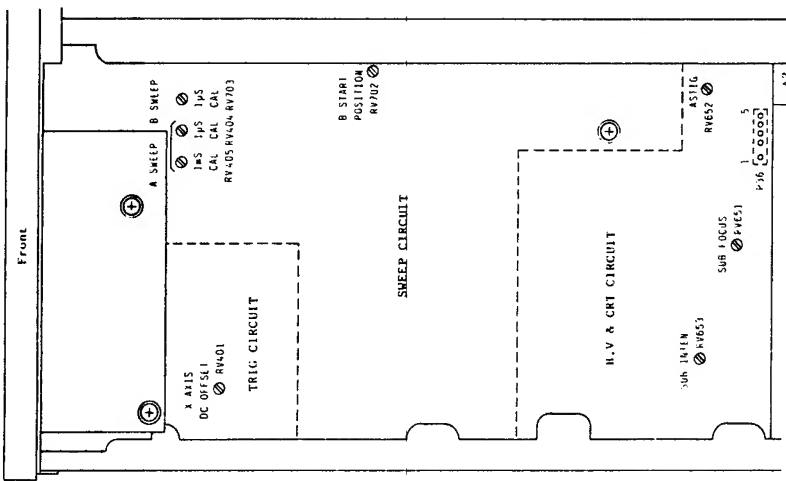

For Service Manuals Contact
MAURITRON TECHNICAL SERVICES
 8 Cherry Tree Rd, Chinnor
 Oxon OX9 4QY
 Tel: 01844-351694 Fax: 01844-352554
 Email: enquiries@mauritron.co.uk

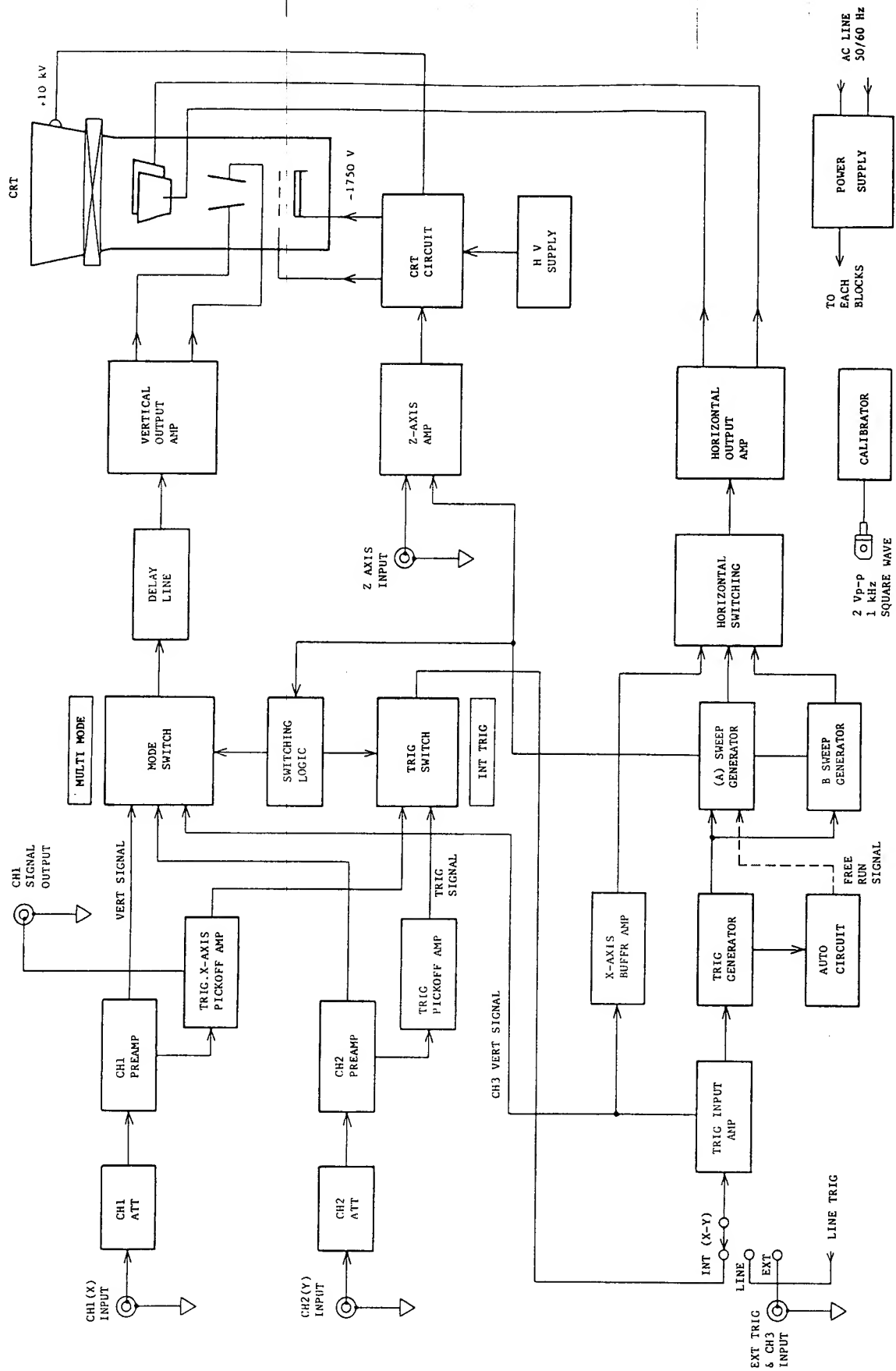

BLOCK DIAGRAM

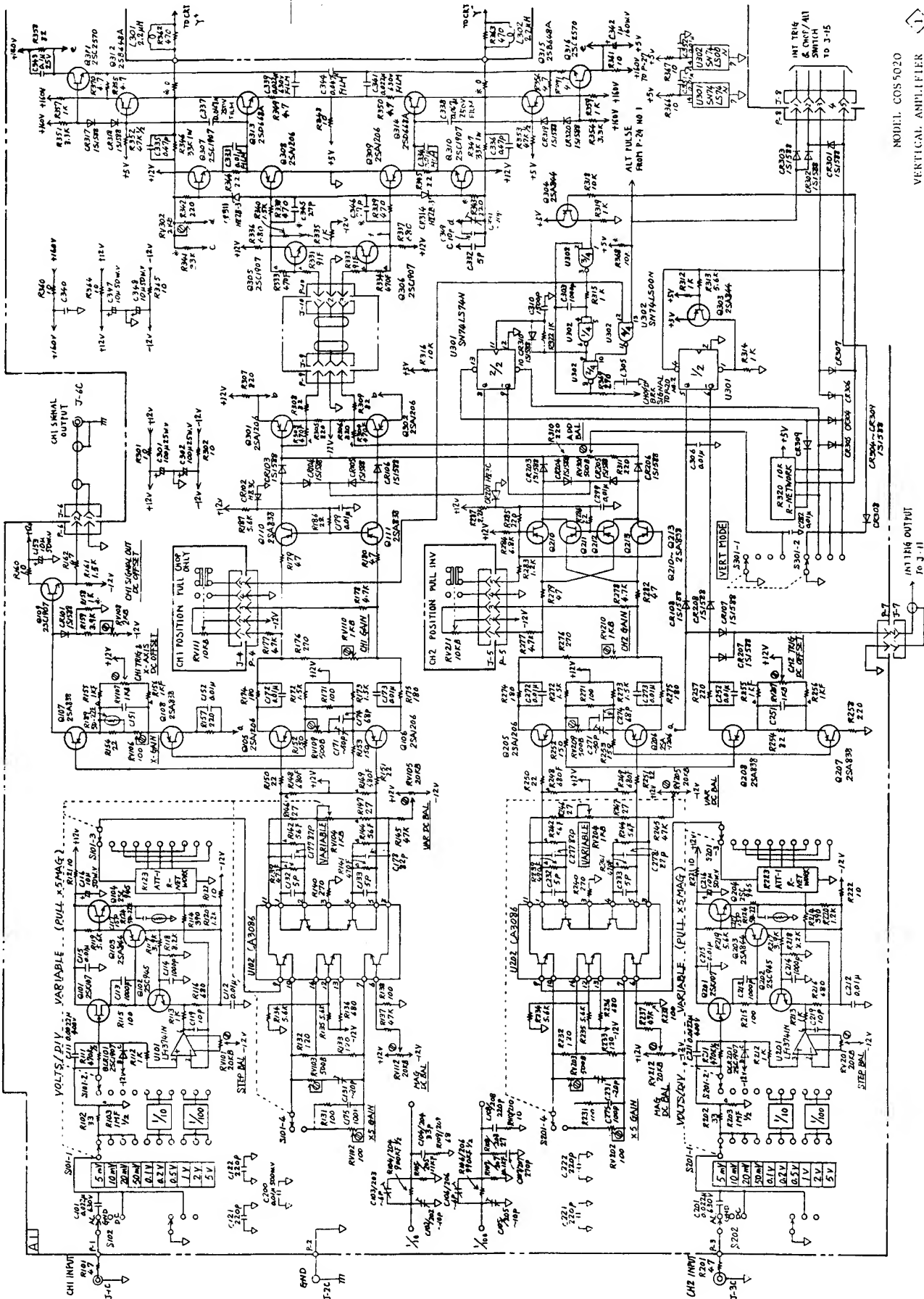

MODEL COS 5020
VERTICAL AMPLIFIER

For Service Manuals Contact
MAURITRON TECHNICAL SERVICES
 8 Cherry Tree Rd, Chinnor
 Oxon OX9 4QY
 Tel: 01844-351694 Fax: 01844-352554
 Email: enquiries@mauritron.co.uk

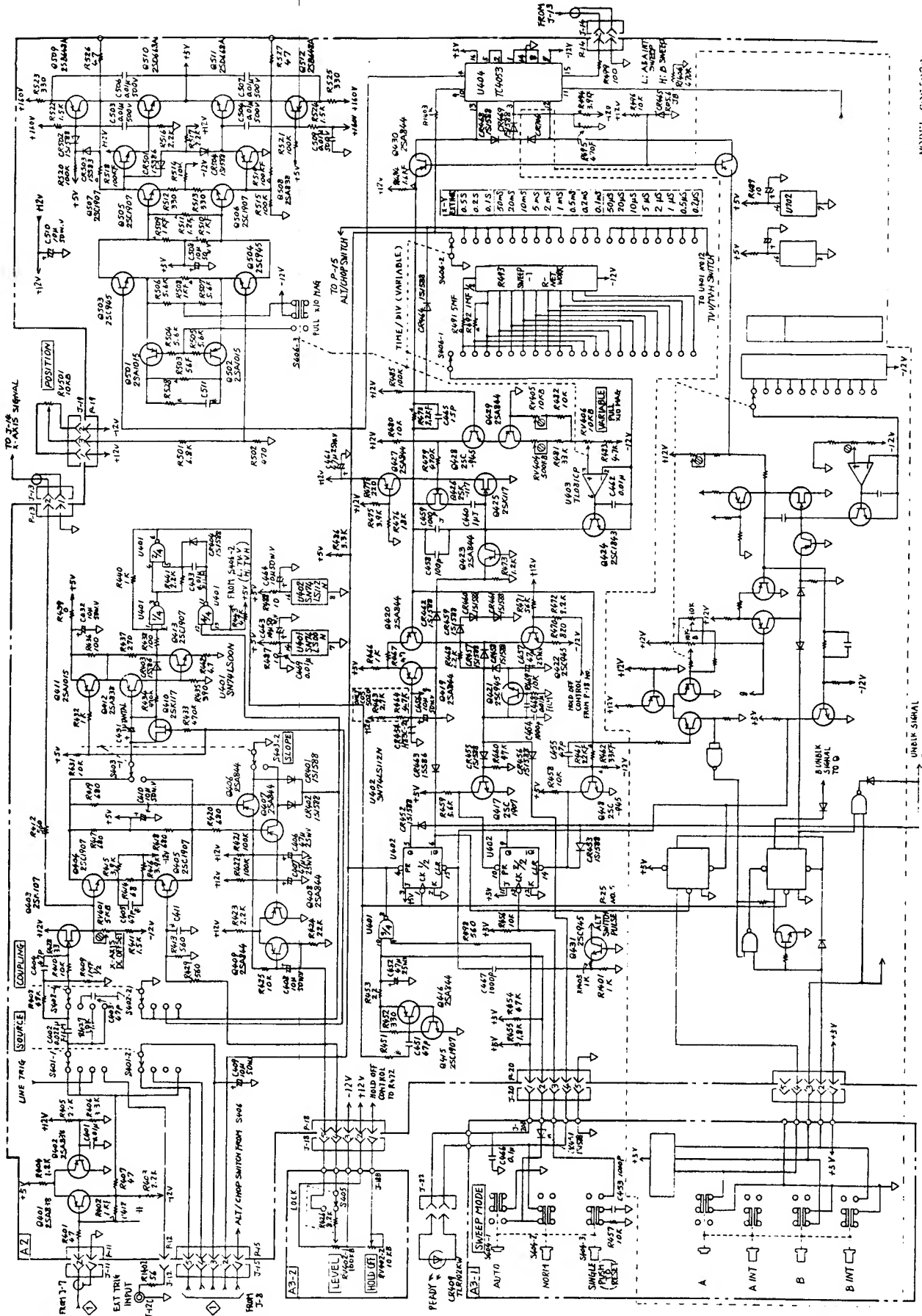

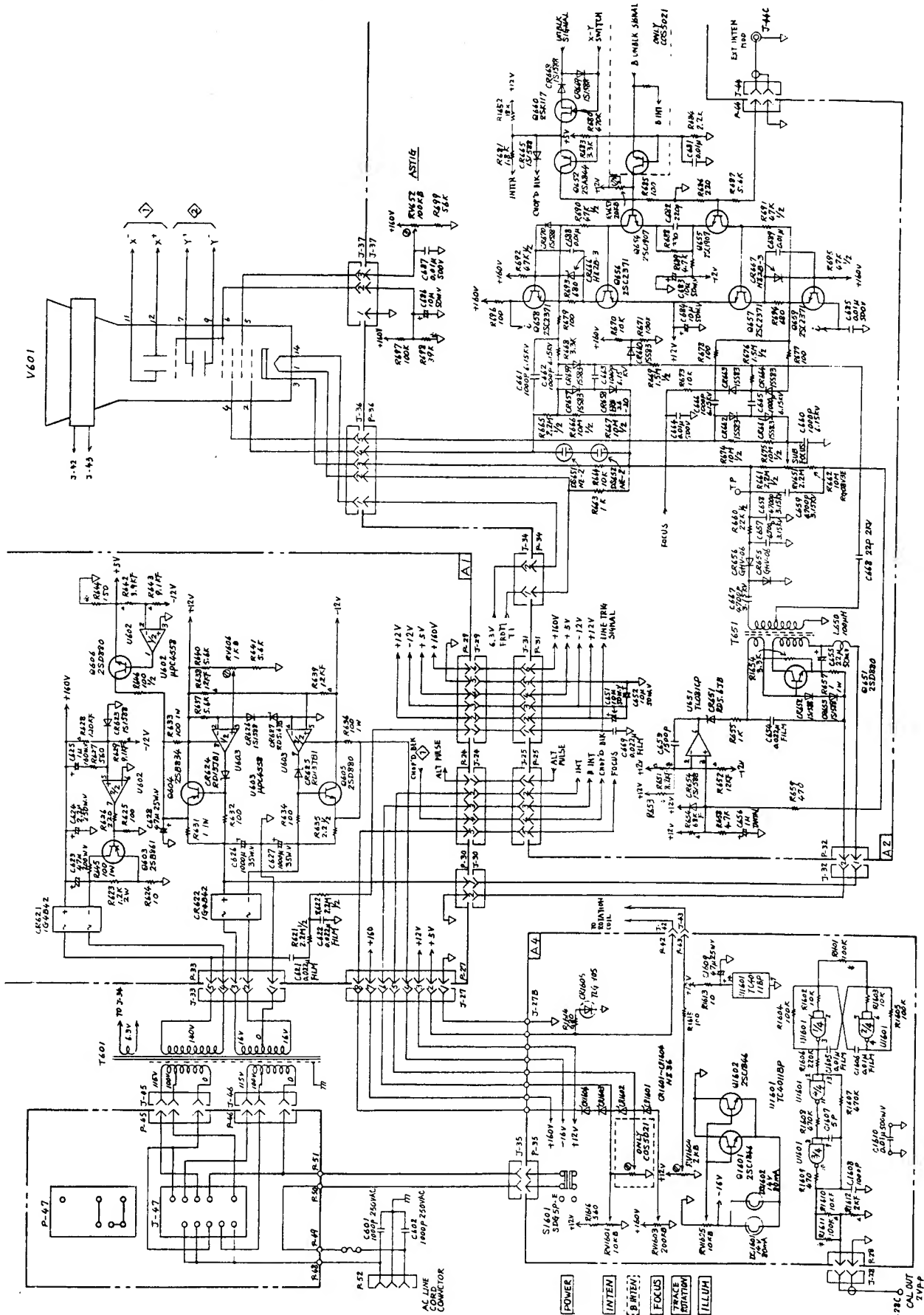

For Service Manuals Contact
MAURITRON TECHNICAL SERVICES
 8 Cherry Tree Rd, Chinnor
 Oxon OX9 4QY
 Tel: 01844-351694 Fax: 01844-352554
 Email: enquiries@mauritron.co.uk

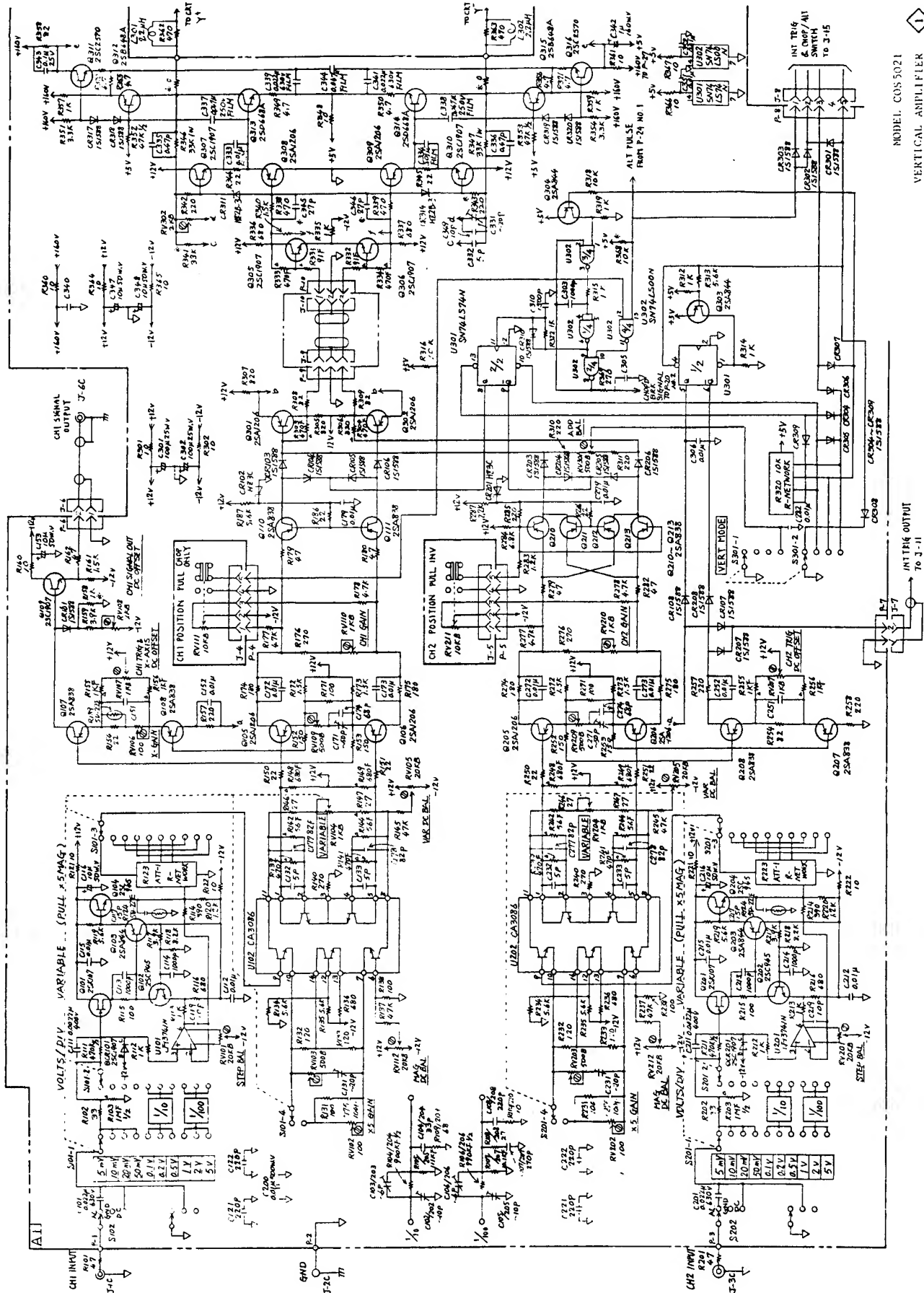

MODEL COS 5021
VERTICAL AMPLIFIER

CH1 SIGNAL OUTPUT
TO J-6C

CH2 INITIAL OUTPUT
TO J-11

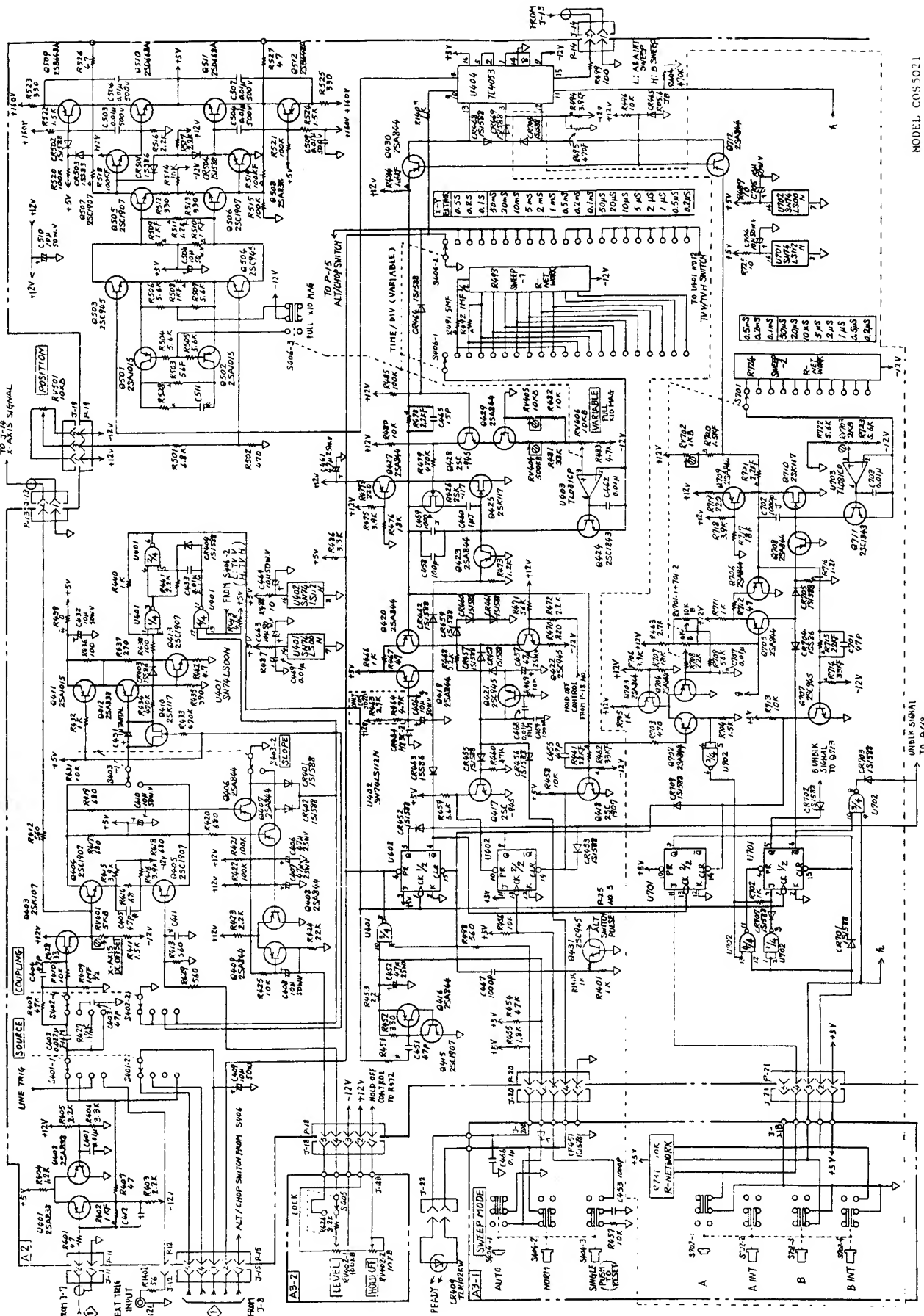

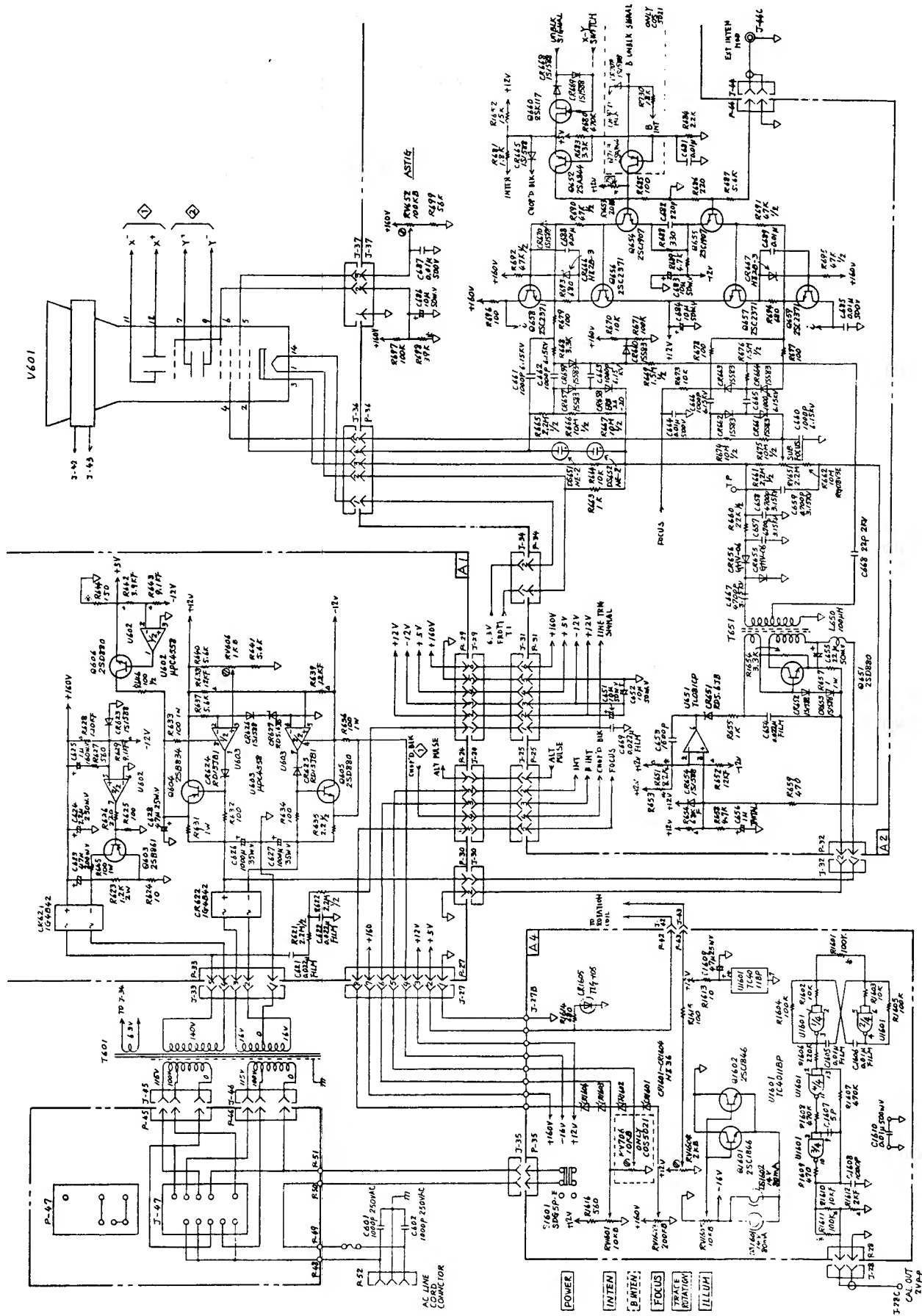

For Service Manuals Contact
MAURITRON TECHNICAL SERVICES
 8 Cherry Tree Rd, Chinnor
 Oxon OX9 4QY
 Tel: 01844-351694 Fax: 01844-352554
 Email: enquiries@mauritron.co.uk

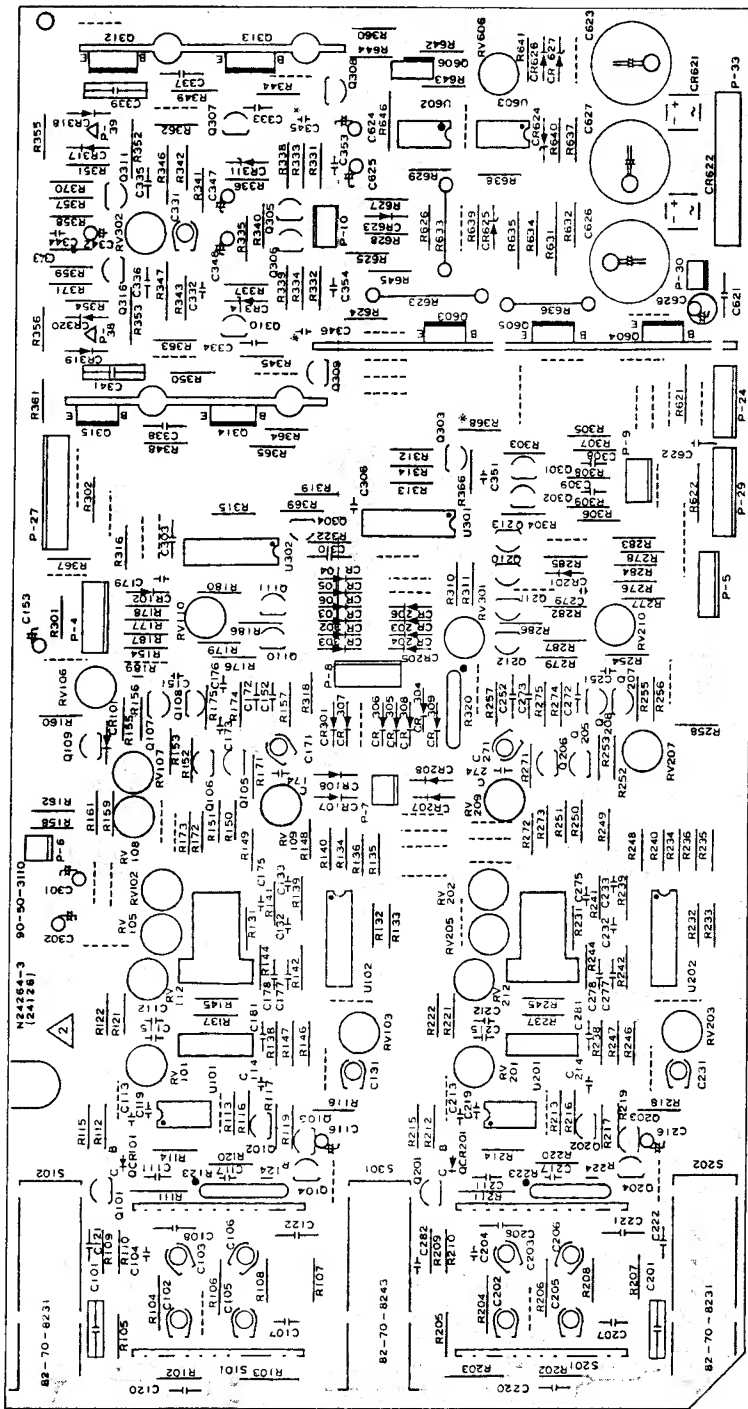

(Parts Side View)

Vert Amp & Power Supply Al Parts Location Diagram

For Service Manuals Contact
MAURITRON TECHNICAL SERVICES
 8 Cherry Tree Rd, Chinnor
 Oxon OX9 4QY
 Tel: 01844-351694 Fax: 01844-352554
 Email: enquiries@mauritron.co.uk

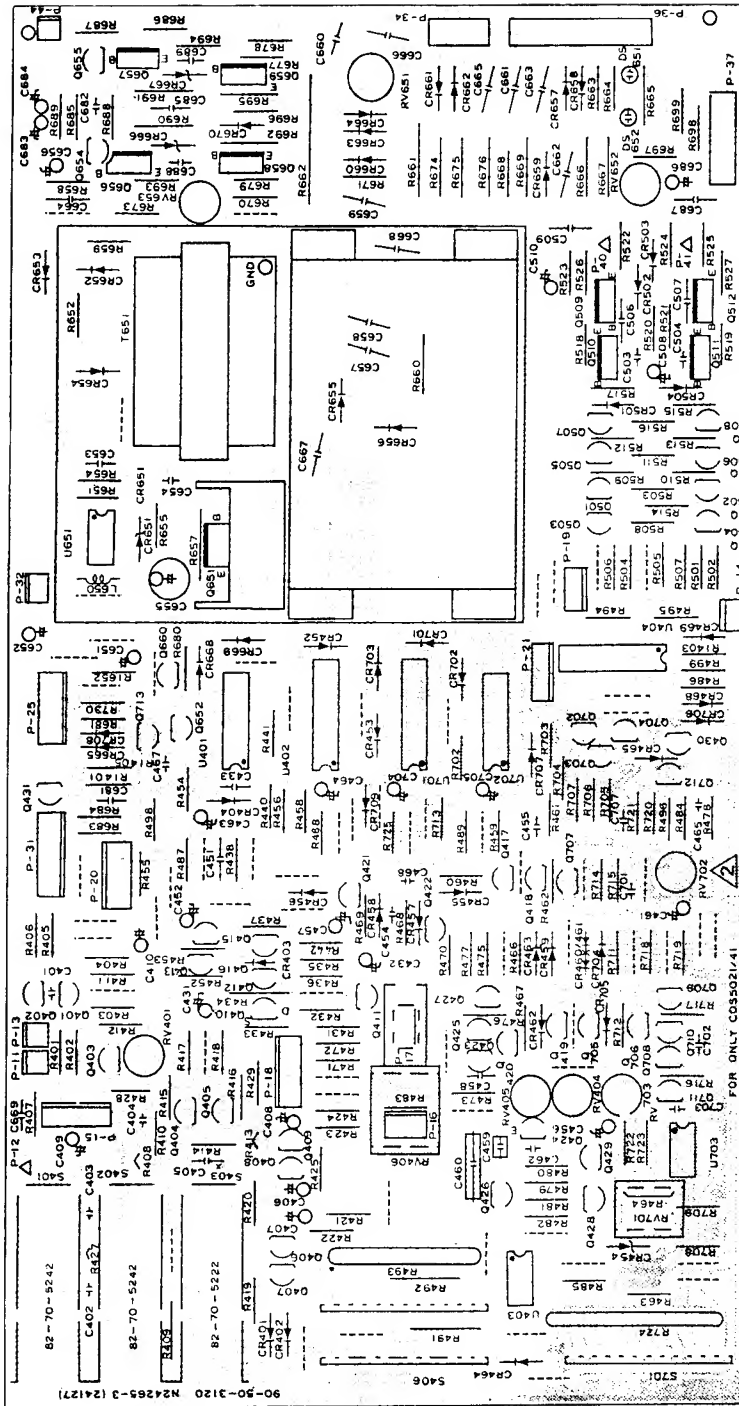

Sweep & H.V. A2 Parts Location Diagram (Parts Side View)

DIGITAL & ANALOG ICs

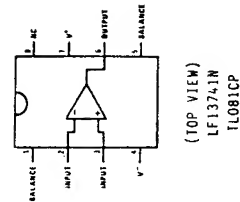
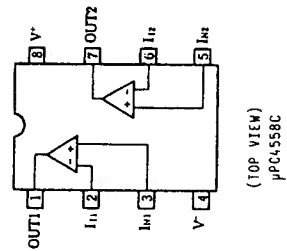
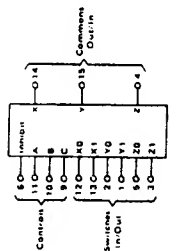
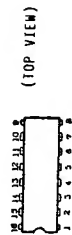
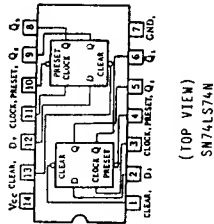
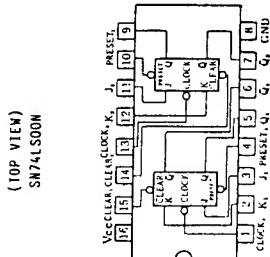
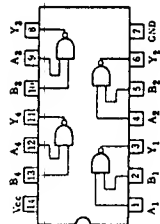
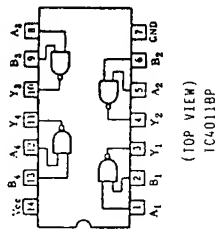

FET

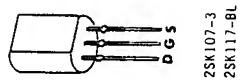

DIODE

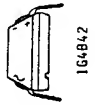
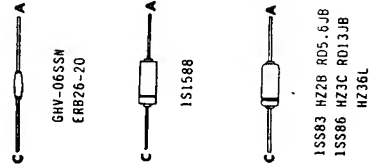

LED



TRANSISTOR

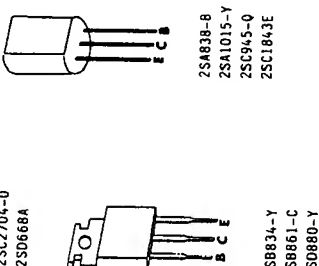
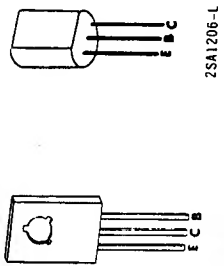
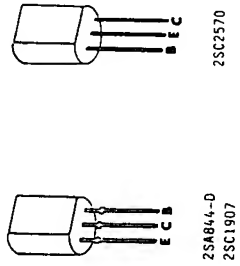

TRANSISTOR ARRAY

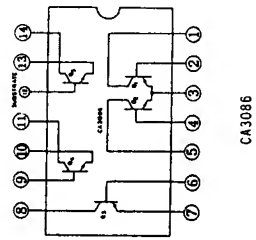

| Control Input | ON Switch | ON Switches |
|---------------|-----------|-------------|
| A | B | A, B |
| B | A | B, A |
| C | A | C, A |
| D | A | D, A |
| E | A | E, A |
| F | A | F, A |
| G | A | G, A |
| H | A | H, A |
| I | A | I, A |
| J | A | J, A |
| K | A | K, A |
| L | A | L, A |
| M | A | M, A |
| N | A | N, A |
| O | A | O, A |
| P | A | P, A |
| Q | A | Q, A |
| R | A | R, A |
| S | A | S, A |
| T | A | T, A |
| U | A | U, A |
| V | A | V, A |
| W | A | W, A |
| X | A | X, A |
| Y | A | Y, A |
| Z | A | Z, A |
| 1 | A | 1, A |
| 2 | A | 2, A |
| 3 | A | 3, A |
| 4 | A | 4, A |
| 5 | A | 5, A |
| 6 | A | 6, A |
| 7 | A | 7, A |
| 8 | A | 8, A |
| 9 | A | 9, A |
| 0 | A | 0, A |

For Service Manuals Contact
MAURITRON TECHNICAL SERVICES
 8 Cherry Tree Rd, Chinnor
 Oxon OX9 4QY
 Tel:- 01844-351634 Fax:- 01844-352554
 Email:- enquiries@mauritron.co.uk

REPLACEABLE PARTS FOR COS5020

ABBREVIATIONS

| | |
|---------------|---|
| CER: | CERAMIC |
| C FILM: | CARBON FILM |
| C COMP: | CARBON COMPOSITION |
| CRT: | CATHODE RAY TUBE |
| ELECT: | ELECTROLYTIC |
| FET: | FIELD EFFECT TRANSISTOR |
| FXD: | FIXED |
| LED: | LIGHT EMITTING DIODE |
| M FILM: | METAL FILM |
| M GLAZE: | METAL GLAZE |
| M OX: | METAL OXIDE |
| M PLSTC FILM: | METALLIZED PLASTIC FILM |
| PLSTC FILM: | PLASTIC FILM |
| Si: | SILICON |
| TANT ELECT: | TANTALUM ELECTROLYTIC |
| VAR: | VARIABLE |
| WW: | WIREWOUND |
| * | OPTIMUM VALUE SELECTED AT FACTORY. AVERAGE VALUE SHOWN. (PART MAY BE OMITTED.) |

REFERENCE DESIGNATOR KIKUSUI PARTS NO.

DESCRIPTION

A1 ASSEMBLY

| REFERENCE DESIGNATOR | KIKUSUI PARTS NO. | DESCRIPTION | |
|----------------------|-------------------|------------------------------|----------------|
| CR101 | 32-11-5880 | DIODE VR=30V IO=120MA | TOSHIBA 1S1588 |
| CR102 | 32-92-0033 | ZENER VZ=3.2-3.4V | HITACHI HZ3C-2 |
| CR103 | 32-11-5880 | DIODE VR=30V IO=120MA | TOSHIBA 1S1588 |
| CR104 | 32-11-5880 | DIODE VR=30V IO=120MA | TOSHIBA 1S1588 |
| CR105 | 32-11-5880 | DIODE VR=30V IO=120MA | TOSHIBA 1S1588 |
| CR106 | 32-11-5880 | DIODE VR=30V IO=120MA | TOSHIBA 1S1588 |
| CR107 | 32-11-5880 | DIODE VR=30V IO=120MA | TOSHIBA 1S1588 |
| CR108 | 32-11-5880 | DIODE VR=30V IO=120MA | TOSHIBA 1S1588 |
| CR201 | 32-92-0033 | ZENER VZ=3.2-3.4V | HITACHI HZ3C-2 |
| CR203 | 32-11-5880 | DIODE VR=30V IO=120MA | TOSHIBA 1S1588 |
| CR204 | 32-11-5880 | DIODE VR=30V IO=120MA | TOSHIBA 1S1588 |
| CR205 | 32-11-5880 | DIODE VR=30V IO=120MA | TOSHIBA 1S1588 |
| CR206 | 32-11-5880 | DIODE VR=30V IO=120MA | TOSHIBA 1S1588 |
| CR207 | 32-11-5880 | DIODE VR=30V IO=120MA | TOSHIBA 1S1588 |
| CR208 | 32-11-5880 | DIODE VR=30V IO=120MA | TOSHIBA 1S1588 |
| CR301 | 32-11-5880 | DIODE VR=30V IO=120MA | TOSHIBA 1S1588 |
| CR302 | 32-11-5880 | DIODE VR=30V IO=120MA | TOSHIBA 1S1588 |
| CR303 | 32-11-5880 | DIODE VR=30V IO=120MA | TOSHIBA 1S1588 |
| CR304 | 32-11-5880 | DIODE VR=30V IO=120MA | TOSHIBA 1S1588 |
| CR305 | 32-11-5880 | DIODE VR=30V IO=120MA | TOSHIBA 1S1588 |
| CR306 | 32-11-5880 | DIODE VR=30V IO=120MA | TOSHIBA 1S1588 |
| CR307 | 32-11-5880 | DIODE VR=30V IO=120MA | TOSHIBA 1S1588 |
| CR308 | 32-11-5880 | DIODE VR=30V IO=120MA | TOSHIBA 1S1588 |
| CR309 | 32-11-5880 | DIODE VR=30V IO=120MA | TOSHIBA 1S1588 |
| CR310 | 32-11-5880 | DIODE VR=30V IO=120MA | TOSHIBA 1S1588 |
| CR311 | 32-92-0022 | ZENER VZ=2.1-2.3V | HITACHI HZ2R-3 |
| CR314 | 32-92-0022 | ZENER VZ=2.1-2.3V | HITACHI HZ2R-3 |
| CR317 | 32-11-5880 | DIODE VR=30V IO=120MA | TOSHIBA 1S1588 |
| CR318 | 32-11-5880 | DIODE VR=30V IO=120MA | TOSHIBA 1S1588 |
| CR319 | 32-11-5880 | DIODE VR=30V IO=120MA | TOSHIBA 1S1588 |
| CR320 | 32-11-5880 | DIODE VR=30V IO=120MA | TOSHIBA 1S1588 |
| CR621 | 32-90-2110 | DIODE BRIDGE VRM=400V IO=1A | TOSHIBA 1G4B42 |
| CR622 | 32-90-2110 | DIODE BRIDGE VRM=400V IO=1A | TOSHIBA 1G4B42 |
| CR623 | 32-11-5880 | DIODE VR=30V IO=120MA | TOSHIBA 1S1588 |
| CR624 | 32-92-0130 | ZENER VZ=12.41-13.05V F=0.4W | NEC RD13J |
| CR625 | 32-92-0130 | ZENER VZ=12.41-13.05V F=0.4W | NEC RD13J |
| CR626 | 32-11-5880 | DIODE VR=30V IO=120MA | TOSHIBA 1S1588 |
| CR627 | 32-92-0056 | ZENER VZ=5.5-5.8V F=0.4W | NEC RDS.6J |
| CR670 | 32-11-5880 | DIODE VR=30V IO=120MA | TOSHIBA 1S1588 |

| | | | |
|------|------------|-----------|---------------------|
| Q101 | 31-20-1073 | FET | SONY 2SK107-3 |
| Q102 | 30-30-9451 | TR SI NPN | NEC 2SC945-Q |
| Q103 | 30-10-8441 | TR SI PNP | HITACHI 2SA844-D |
| Q104 | 30-30-9451 | TR SI NPN | NEC 2SC945-Q |
| Q105 | 30-11-2061 | TR SI PNP | NEC 2SA1206-L |
| Q106 | 30-11-2061 | TR SI PNP | NEC 2SA1206-L |
| Q107 | 30-10-8381 | TR SI PNP | MATSUSHITA 2SA838-B |
| Q108 | 30-10-8381 | TR SI PNP | MATSUSHITA 2SA838-B |
| Q109 | 30-31-9071 | TR SI NPN | HITACHI 2SC1907 |
| Q110 | 30-10-8381 | TR SI PNP | MATSUSHITA 2SA838-B |
| Q111 | 30-10-8381 | TR SI PNP | MATSUSHITA 2SA838-B |
| Q201 | 31-20-1073 | FET | SONY 2SK107-3 |
| Q202 | 30-30-9451 | TR SI NPN | NEC 2SC945-Q |
| Q203 | 30-10-8441 | TR SI PNP | HITACHI 2SA844-D |
| Q204 | 30-30-9451 | TR SI NPN | NEC 2SC945-Q |
| Q205 | 30-11-2061 | TR SI PNP | NEC 2SA1206-L |
| Q206 | 30-11-2061 | TR SI PNP | NEC 2SA1206-L |
| Q207 | 30-10-8381 | TR SI PNP | MATSUSHITA 2SA838-B |
| Q208 | 30-10-8381 | TR SI PNP | MATSUSHITA 2SA838-B |
| Q210 | 30-10-8381 | TR SI PNP | MATSUSHITA 2SA838-B |
| Q211 | 30-10-8381 | TR SI PNP | MATSUSHITA 2SA838-B |
| Q212 | 30-10-8381 | TR SI PNP | MATSUSHITA 2SA838-B |
| Q213 | 30-10-8381 | TR SI PNP | MATSUSHITA 2SA838-B |
| Q301 | 30-11-2061 | TR SI PNP | NEC 2SA1206-L |
| Q302 | 30-11-2061 | TR SI PNP | NEC 2SA1206-L |
| Q303 | 30-10-8441 | TR SI PNP | HITACHI 2SA844-D |
| Q304 | 30-10-8441 | TR SI PNP | HITACHI 2SA844-D |
| Q305 | 30-31-9071 | TR SI NPN | HITACHI 2SC1907 |
| Q306 | 30-31-9071 | TR SI NPN | HITACHI 2SC1907 |
| Q307 | 30-31-9071 | TR SI NPN | HITACHI 2SC1907 |
| Q308 | 30-11-2061 | TR SI PNP | NEC 2SA1206-L |
| Q309 | 30-11-2061 | TR SI PNP | NEC 2SA1206-L |
| Q310 | 30-31-9071 | TR SI NPN | HITACHI 2SC1907 |
| Q311 | 30-32-5700 | TR SI NPN | NEC 2SC2570 |
| Q312 | 30-20-6481 | TR SI PNP | HITACHI 2SB648A |
| Q313 | 30-40-6681 | TR SI NPN | HITACHI 2SD668A-C |

For Service Manuals Contact
MAURITRON TECHNICAL SERVICES
 8 Cherry Tree Rd, Chinnor
 Oxon OX9 4QY
 Tel: 01844-351694 Fax: 01844-352554
 Email: enquiries@mauritron.co.uk

| REFERENCE DESIGNATOR | KIKUSUI PARTS NO. | DESCRIPTION | |
|----------------------|-------------------|-------------------------|-------------------|
| Q314 | 30-40-6681 | TR SI NPN | HITACHI 2SD668A-C |
| Q315 | 30-20-6481 | TR SI PNP | HITACHI 2SB648A |
| Q316 | 30-32-5700 | TR SI NPN | NEC 2SC2570 |
| Q603 | 30-20-8611 | TR SI PNP | HITACHI 2SB861-C |
| Q604 | 30-20-8341 | TR SI PNP | TOSHIBA 2SB834-Y |
| Q605 | 30-40-8802 | TR SI NPN | NEC 2SD880-Y |
| Q606 | 30-40-8802 | TR SI NPN | NEC 2SD880-Y |
| QCR101 | 30-31-9071 | TR SI NPN | HITACHI 2SC1907 |
| QCR201 | 30-31-9071 | TR SI NPN | HITACHI 2SC1907 |
| U101 | 34-00-0121 | FET OPEAMP | N.S LF13741N |
| U102 | 30-90-0141 | TRANSISTOR ARRAYS 5 NPN | RCA CA3086 |
| U201 | 34-00-0121 | FET OPEAMP | N.S LF13741N |
| U202 | 30-90-0141 | TRANSISTOR ARRAYS 5 NPN | RCA CA3086 |
| U301 | 35-70-0741 | DUAL D-FLIP FLOP | T.I SN74LS74N |
| U302 | 35-70-0001 | QUAD 2-INPUT POSI-NAND | T.I SN74LS00N |
| U602 | 34-00-0240 | DUAL OPEAMP | NEC UPC4558C |
| U603 | 34-00-0240 | DUAL OPEAMP | NEC UPC4558C |
| R102 | 40-27-0332 | FXD C FILM | 33 OHM 5% 1/4W |
| R103 | 42-74-5100 | FXD M FILM | 1M OHM 1% 1/2W |
| R104 | 42-74-4900 | FXD M FILM | 900K OHM 1% 1/2W |
| R105 | 42-72-4111 | FXD M FILM | 111K OHM 1% 1/4W |
| R106 | 42-74-4990 | FXD M FILM | 990K OHM 1% 1/2W |
| R107 | 42-72-3101 | FXD M FILM | 10.1K OHM 1% 1/4W |
| R108 | 40-27-0222 | FXD C FILM | 22 OHM 5% 1/4W |
| R109 | 40-27-0682 | FXD C FILM | 68 OHM 5% 1/4W |
| R110 | 40-27-0102 | FXD C FILM | 10 OHM 5% 1/4W |
| R111 | 40-37-4471 | FXD C FILM | 470K OHM 5% 1/2W |
| R112 | 40-27-2102 | FXD C FILM | 1K OHM 5% 1/4W |
| R113 | 40-27-2562 | FXD C FILM | 5.6K OHM 5% 1/4W |
| R114 | 40-27-2102 | FXD C FILM | 1K OHM 5% 1/4W |
| R115 | 40-27-1102 | FXD C FILM | 100 OHM 5% 1/4W |
| R116 | 40-27-1682 | FXD C FILM | 680 OHM 5% 1/4W |
| R117 | 40-27-2392 | FXD C FILM | 3.9K OHM 5% 1/4W |
| R118 | 40-27-2822 | FXD C FILM | 8.2K OHM 5% 1/4W |
| R119 | 40-27-2562 | FXD C FILM | 5.6K OHM 5% 1/4W |
| R120 | 40-27-2122 | FXD C FILM | 1.2K OHM 5% 1/4W |
| R121 | 40-27-0102 | FXD C FILM | 10 OHM 5% 1/4W |
| R122 | 40-27-0102 | FXD C FILM | 10 OHM 5% 1/4W |
| R123 | 44-04-0000 | FXD M GLAZE | R-NETWORK |
| R124 | 38-00-0000 | THERMISTER | 250 OHM |
| R131 | 40-27-1102 | FXD C FILM | 100 OHM 5% 1/4W |
| R132 | 40-27-1122 | FXD C FILM | 120 OHM 5% 1/4W |
| R133 | 40-27-1122 | FXD C FILM | 120 OHM 5% 1/4W |
| R134 | 40-27-2562 | FXD C FILM | 5.6K OHM 5% 1/4W |
| R135 | 40-27-2562 | FXD C FILM | 5.6K OHM 5% 1/4W |
| R136 | 40-27-1682 | FXD C FILM | 680 OHM 5% 1/4W |
| R137 | 40-27-3472 | FXD C FILM | 47K OHM 5% 1/4W |
| R138 | 40-27-1102 | FXD C FILM | 100 OHM 5% 1/4W |
| R139 | 42-72-1470 | FXD M FILM | 470 OHM 1% 1/4W |
| R140 | 40-27-1272 | FXD C FILM | 270 OHM 5% 1/4W |
| R141 | 42-72-1470 | FXD M FILM | 470 OHM 1% 1/4W |
| R142 | 42-72-0560 | FXD M FILM | 56 OHM 1% 1/4W |
| R144 | 42-72-0560 | FXD M FILM | 56 OHM 1% 1/4W |
| R145 | 40-27-3472 | FXD C FILM | 47K OHM 5% 1/4W |
| R146 | 40-27-0272 | FXD C FILM | 27 OHM 5% 1/4W |
| R147 | 40-27-0272 | FXD C FILM | 27 OHM 5% 1/4W |
| R148 | 42-72-1680 | FXD M FILM | 680 OHM 1% 1/4W |
| R149 | 42-72-1680 | FXD M FILM | 680 OHM 1% 1/4W |
| R150 | 40-27-0222 | FXD C FILM | 22 OHM 5% 1/4W |
| R151 | 40-27-0222 | FXD C FILM | 22 OHM 5% 1/4W |
| R152 | 40-27-1152 | FXD C FILM | 150 OHM 5% 1/4W |
| R153 | 40-27-1152 | FXD C FILM | 150 OHM 5% 1/4W |
| R154 | 40-27-0222 | FXD C FILM | 22 OHM 5% 1/4W |
| R155 | 42-72-2100 | FXD M FILM | 1K OHM 1% 1/4W |
| R156 | 42-72-2100 | FXD M FILM | 1K OHM 1% 1/4W |
| R157 | 40-27-1222 | FXD C FILM | 220 OHM 5% 1/4W |
| R158 | * 40-27-2102 | FXD C FILM | 1K OHM 5% 1/4W |
| R159 | 40-27-2392 | FXD C FILM | 3.9K OHM 5% 1/4W |
| R160 | 40-27-0102 | FXD C FILM | 10 OHM 5% 1/4W |
| R161 | 40-27-2152 | FXD C FILM | 1.5K OHM 5% 1/4W |
| R162 | 40-27-0472 | FXD C FILM | 47 OHM 5% 1/4W |
| R171 | 40-27-1122 | FXD C FILM | 120 OHM 5% 1/4W |
| R172 | 40-27-2152 | FXD C FILM | 1.5K OHM 5% 1/4W |
| R173 | 40-27-2152 | FXD C FILM | 1.5K OHM 5% 1/4W |

KIKUSUI S8109001

| REFERENCE DESIGNATOR | KIKUSUI PARTS NO. | DESCRIPTION |
|----------------------|-------------------|------------------------------|
| R174 | 40-27-1182 | FXD C FILM 180 OHM 5% 1/4W |
| R175 | 40-27-1182 | FXD C FILM 180 OHM 5% 1/4W |
| R176 | 40-27-1272 | FXD C FILM 270 OHM 5% 1/4W |
| R177 | 40-27-2472 | FXD C FILM 4.7K OHM 5% 1/4W |
| R178 | 40-27-2472 | FXD C FILM 4.7K OHM 5% 1/4W |
| R179 | 40-27-0472 | FXD C FILM 47 OHM 5% 1/4W |
| R180 | 40-27-0472 | FXD C FILM 47 OHM 5% 1/4W |
| R186 | 40-27-0222 | FXD C FILM 22 OHM 5% 1/4W |
| R187 | 40-27-2562 | FXD C FILM 5.6K OHM 5% 1/4W |
| R189 | 38-00-0000 | THERMISTER 250 OHM |
| R202 | 40-27-0332 | FXD C FILM 33 OHM 5% 1/4W |
| R203 | 42-74-5100 | FXD M FILM 1M OHM 1% 1/2W |
| R204 | 42-74-4900 | FXD M FILM 900K OHM 1% 1/2W |
| R205 | 42-72-4111 | FXD M FILM 111K OHM 1% 1/4W |
| R206 | 42-74-4990 | FXD M FILM 990K OHM 1% 1/2W |
| R207 | 42-72-3101 | FXD M FILM 10.1K OHM 1% 1/4W |
| R208 | 40-27-0222 | FXD C FILM 22 OHM 5% 1/4W |
| R209 | 40-27-0682 | FXD C FILM 68 OHM 5% 1/4W |
| R210 | 40-27-0102 | FXD C FILM 10 OHM 5% 1/4W |
| R211 | 40-37-4471 | FXD C FILM 470K OHM 5% 1/2W |
| R212 | 40-27-2102 | FXD C FILM 1K OHM 5% 1/4W |
| R213 | 40-27-2562 | FXD C FILM 5.6K OHM 5% 1/4W |
| R214 | 40-27-2102 | FXD C FILM 1K OHM 5% 1/4W |
| R215 | 40-27-1102 | FXD C FILM 100 OHM 5% 1/4W |
| R216 | 40-27-1682 | FXD C FILM 680 OHM 5% 1/4W |
| R217 | 40-27-2392 | FXD C FILM 3.9K OHM 5% 1/4W |
| R218 | 40-27-2822 | FXD C FILM 8.2K OHM 5% 1/4W |
| R219 | 40-27-2562 | FXD C FILM 5.6K OHM 5% 1/4W |
| R220 | 40-27-2122 | FXD C FILM 1.2K OHM 5% 1/4W |
| R221 | 40-27-0102 | FXD C FILM 10 OHM 5% 1/4W |
| R222 | 40-27-0102 | FXD C FILM 10 OHM 5% 1/4W |
| R223 | 44-04-0000 | FXD M GLAZE R-NETWORK |
| R231 | 40-27-1102 | FXD C FILM 100 OHM 5% 1/4W |
| R232 | 40-27-1122 | FXD C FILM 120 OHM 5% 1/4W |
| R233 | 40-27-1122 | FXD C FILM 120 OHM 5% 1/4W |
| R234 | 40-27-2562 | FXD C FILM 5.6K OHM 5% 1/4W |
| R235 | 40-27-2562 | FXD C FILM 5.6K OHM 5% 1/4W |
| R236 | 40-27-1682 | FXD C FILM 680 OHM 5% 1/4W |
| R237 | 40-27-3472 | FXD C FILM 47K OHM 5% 1/4W |
| R238 | 40-27-1102 | FXD C FILM 100 OHM 5% 1/4W |
| R239 | 42-72-1470 | FXD M FILM 470 OHM 1% 1/4W |
| R240 | 40-27-1272 | FXD C FILM 270 OHM 5% 1/4W |
| R241 | 42-72-1470 | FXD M FILM 470 OHM 1% 1/4W |
| R242 | 42-72-0560 | FXD M FILM 56 OHM 1% 1/4W |
| R244 | 42-72-0560 | FXD M FILM 56 OHM 1% 1/4W |
| R245 | 40-27-3472 | FXD C FILM 47K OHM 5% 1/4W |
| R246 | 40-27-0272 | FXD C FILM 27 OHM 5% 1/4W |
| R247 | 40-27-0272 | FXD C FILM 27 OHM 5% 1/4W |
| R248 | 42-72-1680 | FXD M FILM 680 OHM 1% 1/4W |
| R249 | 42-72-1680 | FXD M FILM 680 OHM 1% 1/4W |
| R250 | 40-27-0222 | FXD C FILM 22 OHM 5% 1/4W |
| R251 | 40-27-0222 | FXD C FILM 22 OHM 5% 1/4W |
| R252 | 40-27-1152 | FXD C FILM 150 OHM 5% 1/4W |
| R253 | 40-27-1152 | FXD C FILM 150 OHM 5% 1/4W |
| R254 | 40-27-0822 | FXD C FILM 82 OHM 5% 1/4W |
| R255 | 42-72-2100 | FXD M FILM 1K OHM 1% 1/4W |
| R256 | 42-72-2100 | FXD M FILM 1K OHM 1% 1/4W |
| R257 | 40-27-1222 | FXD C FILM 220 OHM 5% 1/4W |
| R258 | 40-27-1222 | FXD C FILM 220 OHM 5% 1/4W |
| R271 | 40-27-1122 | FXD C FILM 120 OHM 5% 1/4W |
| R272 | 40-27-2152 | FXD C FILM 1.5K OHM 5% 1/4W |
| R273 | 40-27-2152 | FXD C FILM 1.5K OHM 5% 1/4W |
| R274 | 40-27-1182 | FXD C FILM 180 OHM 5% 1/4W |
| R275 | 40-27-1182 | FXD C FILM 180 OHM 5% 1/4W |
| R276 | 40-27-1272 | FXD C FILM 270 OHM 5% 1/4W |
| R277 | 40-27-2472 | FXD C FILM 4.7K OHM 5% 1/4W |
| R278 | 40-27-2472 | FXD C FILM 4.7K OHM 5% 1/4W |
| R279 | 40-27-0472 | FXD C FILM 47 OHM 5% 1/4W |
| R282 | 40-27-0472 | FXD C FILM 47 OHM 5% 1/4W |
| R283 | 40-27-2122 | FXD C FILM 1.2K OHM 5% 1/4W |
| R284 | 40-27-2682 | FXD C FILM 6.8K OHM 5% 1/4W |
| R285 | 40-27-1222 | FXD C FILM 220 OHM 5% 1/4W |
| R286 | 40-27-0222 | FXD C FILM 22 OHM 5% 1/4W |
| R287 | 40-27-2222 | FXD C FILM 2.2K OHM 5% 1/4W |
| R301 | 40-27-0102 | FXD C FILM 10 OHM 5% 1/4W |
| R302 | 40-27-0102 | FXD C FILM 10 OHM 5% 1/4W |
| R303 | 42-72-1470 | FXD M FILM 470 OHM 1% 1/4W |

KIKUSUI S8109001

For Service Manuals Contact
MAURITRON TECHNICAL SERVICES
8 Cherry Tree Rd, Chinnor
Oxon OX9 4QY
Tel: 01844-351694 Fax: 01844-352554
Email: enquiries@mauritron.co.uk

| REFERENCE DESIGNATOR | KIKUSUI PARTS NO. | DESCRIPTION |
|----------------------|-------------------|--|
| R304 | 42-72-1470 | FXD M FILM 470 OHM 1% 1/4W |
| R305 | 40-27-1822 | FXD C FILM 820 OHM 5% 1/4W |
| R306 | 40-27-1822 | FXD C FILM 820 OHM 5% 1/4W |
| R307 | 40-27-1822 | FXD C FILM 820 OHM 5% 1/4W |
| R308 | 40-27-0822 | FXD C FILM 82 OHM 5% 1/4W |
| R309 | 40-27-0822 | FXD C FILM 82 OHM 5% 1/4W |
| R310 | 40-27-1222 | FXD C FILM 220 OHM 5% 1/4W |
| R311 | 40-27-1222 | FXD C FILM 220 OHM 5% 1/4W |
| R312 | 40-27-2102 | FXD C FILM 1K OHM 5% 1/4W |
| R313 | 40-27-2562 | FXD C FILM 5.6K OHM 5% 1/4W |
| R314 | 40-27-2102 | FXD C FILM 1K OHM 5% 1/4W |
| R315 | 40-27-2102 | FXD C FILM 1K OHM 5% 1/4W |
| R316 | 40-27-3102 | FXD C FILM 10K OHM 5% 1/4W |
| R318 | 40-27-3102 | FXD C FILM 10K OHM 5% 1/4W |
| R319 | 40-27-2102 | FXD C FILM 1K OHM 5% 1/4W |
| R320 | 44-07-0020 | FXD M GLAZE RESISTOR NETWORKS 10K OHM X4 |
| R322 | 40-27-2102 | FXD C FILM 1K OHM 5% 1/4W |
| R331 | 42-72-0910 | FXD M FILM 91 OHM 1% 1/4W |
| R332 | 42-72-0910 | FXD M FILM 91 OHM 1% 1/4W |
| R333 | 42-72-1470 | FXD M FILM 470 OHM 1% 1/4W |
| R334 | 42-72-1470 | FXD M FILM 470 OHM 1% 1/4W |
| R335 | 40-27-2102 | FXD C FILM 1K OHM 5% 1/4W |
| R336 | 40-27-1682 | FXD C FILM 680 OHM 5% 1/4W |
| R337 | 40-27-1682 | FXD C FILM 680 OHM 5% 1/4W |
| R338 | 40-27-1472 | FXD C FILM 470 OHM 5% 1/4W |
| R339 | 40-27-1472 | FXD C FILM 470 OHM 5% 1/4W |
| R340 | 40-27-2152 | FXD C FILM 1.5K OHM 5% 1/4W |
| R341 | * 40-27-3272 | FXD C FILM 27K OHM 5% 1/4W |
| R342 | 40-27-1222 | FXD C FILM 220 OHM 5% 1/4W |
| R343 | 40-27-1222 | FXD C FILM 220 OHM 5% 1/4W |
| R344 | 40-27-0222 | FXD C FILM 22 OHM 5% 1/4W |
| R345 | 40-27-0222 | FXD C FILM 22 OHM 5% 1/4W |
| R346 | 44-91-3330 | FXD M OXIDE 33K OHM 5% 1W |
| R347 | 44-91-3330 | FXD M OXIDE 33K OHM 5% 1W |
| R348 | 40-27-0102 | FXD C FILM 10 OHM 5% 1/4W |
| R349 | 40-27-8472 | FXD C FILM 4.7 OHM 5% 1/4W |
| R350 | 40-27-8472 | FXD C FILM 4.7 OHM 5% 1/4W |
| R351 | 40-27-2332 | FXD C FILM 3.3K OHM 5% 1/4W |
| R352 | 40-37-3471 | FXD C FILM 47K OHM 5% 1/2W |
| R353 | 40-37-3471 | FXD C FILM 47K OHM 5% 1/2W |
| R354 | 40-27-2332 | FXD C FILM 3.3K OHM 5% 1/4W |
| R355 | 40-27-8472 | FXD C FILM 4.7 OHM 5% 1/4W |
| R356 | 40-27-8472 | FXD C FILM 4.7 OHM 5% 1/4W |
| R357 | 40-27-2102 | FXD C FILM 1K OHM 5% 1/4W |
| R358 | 40-27-0822 | FXD C FILM 82 OHM 5% 1/4W |
| R359 | 40-27-2102 | FXD C FILM 1K OHM 5% 1/4W |
| R360 | 40-27-0102 | FXD C FILM 10 OHM 5% 1/4W |
| R361 | 40-27-0102 | FXD C FILM 10 OHM 5% 1/4W |
| R362 | 40-27-1472 | FXD C FILM 470 OHM 5% 1/4W |
| R363 | 40-27-1472 | FXD C FILM 470 OHM 5% 1/4W |
| R364 | 40-27-0102 | FXD C FILM 10 OHM 5% 1/4W |
| R365 | 40-27-0102 | FXD C FILM 10 OHM 5% 1/4W |
| R366 | 40-27-0102 | FXD C FILM 10 OHM 5% 1/4W |
| R367 | * 40-27-0102 | FXD C FILM 10 OHM 5% 1/4W |
| R368 | * 40-27-3102 | FXD C FILM 10K OHM 5% 1/4W |
| R369 | 40-27-1272 | FXD C FILM 270 OHM 5% 1/4W |
| R370 | 40-27-8472 | FXD C FILM 4.7 OHM 5% 1/4W |
| R371 | 40-27-8472 | FXD C FILM 4.7 OHM 5% 1/4W |
| R621 | 40-37-5221 | FXD C FILM 2.2M OHM 5% 1/2W |
| R622 | 40-37-5221 | FXD C FILM 2.2M OHM 5% 1/2W |
| R623 | 44-92-2120 | FXD M OXIDE 1.2K OHM 5% 2W |
| R624 | 40-27-0102 | FXD C FILM 10 OHM 5% 1/4W |
| R625 | 40-27-1102 | FXD C FILM 100 OHM 5% 1/4W |
| R626 | 40-27-1222 | FXD C FILM 220 OHM 5% 1/4W |
| R627 | 40-27-1562 | FXD C FILM 560 OHM 5% 1/4W |
| R628 | 42-72-4120 | FXD M FILM 120K OHM 1% 1/4W |
| R629 | 42-72-2910 | FXD M FILM 9.1K OHM 1% 1/4W |
| R631 | 44-91-0010 | FXD M OXIDE 1 OHM 5% 1W |
| R632 | 40-27-1102 | FXD C FILM 100 OHM 5% 1/4W |
| R633 | 44-91-1100 | FXD M OXIDE 100 OHM 5% 1W |
| R634 | 40-27-1102 | FXD C FILM 100 OHM 5% 1/4W |
| R635 | 40-37-8222 | FXD C FILM 2.2 OHM 5% 1/2W |
| R636 | 44-91-1100 | FXD M OXIDE 100 OHM 5% 1W |
| R637 | 40-27-2562 | FXD C FILM 5.6K OHM 5% 1/4W |
| R638 | 42-72-3120 | FXD M FILM 12K OHM 1% 1/4W |
| R639 | 42-72-3120 | FXD M FILM 12K OHM 1% 1/4W |
| R640 | 40-27-2562 | FXD C FILM 5.6K OHM 5% 1/4W |

| REFERENCE DESIGNATOR | KIKUSUI PARTS NO. | DESCRIPTION |
|----------------------|-------------------|-----------------------------------|
| R641 | 40-27-2562 | FXD C FILM 5.6K OHM 5% 1/4W |
| R642 | 42-72-2390 | FXD M FILM 3.9K OHM 1% 1/4W |
| R643 | 42-72-2910 | FXD M FILM 9.1K OHM 1% 1/4W |
| R644 | * 40-27-1152 | FXD C FILM 150 OHM 5% 1/4W |
| R646 | 40-37-1101 | FXD C FILM 100 OHM 5% 1/2W |
| RV101 | 48-33-3200 | VAR M FILM 20K OHM |
| RV102 | 48-33-1100 | VAR M FILM 100 OHM |
| RV103 | 48-33-1500 | VAR M FILM 500 OHM |
| RV105 | 48-33-3200 | VAR M FILM 20K OHM |
| RV106 | 48-33-1100 | VAR M FILM 100 OHM |
| RV107 | 48-33-2100 | VAR M FILM 1K OHM |
| RV108 | 48-33-2200 | VAR M FILM 2K OHM |
| RV109 | 48-33-1500 | VAR M FILM 500 OHM |
| RV110 | 48-33-2100 | VAR M FILM 1K OHM |
| RV112 | 48-33-3200 | VAR M FILM 20K OHM |
| RV201 | 48-33-3200 | VAR M FILM 20K OHM |
| RV202 | 48-33-1100 | VAR M FILM 100 OHM |
| RV203 | 48-33-1500 | VAR M FILM 500 OHM |
| RV205 | 48-33-3200 | VAR M FILM 20K OHM |
| RV207 | 48-33-2100 | VAR M FILM 1K OHM |
| RV209 | 48-33-1500 | VAR M FILM 500 OHM |
| RV210 | 48-33-2100 | VAR M FILM 1K OHM |
| RV212 | 48-33-3200 | VAR M FILM 20K OHM |
| RV301 | 48-33-1500 | VAR M FILM 500 OHM |
| RV302 | 48-33-2200 | VAR M FILM 2K OHM |
| RV606 | 48-33-2100 | VAR M FILM 1K OHM |
| C101 | 50-96-3590 | FXD PLSTC FILM 0.022UF 20% 630V |
| C102 | 57-10-1191 | VAR CER 3-10PF |
| C103 | 57-10-1181 | VAR CER 3-6PF |
| C104 | 52-06-3165 | FXD CER 33PF 10% 500V TYPE1 |
| C105 | 57-10-1191 | VAR CER 3-10PF |
| C106 | 57-10-1181 | VAR CER 3-6PF |
| C107 | 52-06-2265 | FXD CER 220PF 10% 50V TYPE1 |
| C108 | 52-06-2265 | FXD CER 220PF 10% 50V TYPE1 |
| C111 | 50-87-0510 | FXD PLSTC FILM 2200PF 10% 400V |
| C112 | 52-05-2468 | FXD CER 0.01UF +80-20% 50V TYPE2 |
| C113 | 52-01-3345 | FXD CER 1000PF 10% 500V TYPE2 |
| C114 | 52-01-3345 | FXD CER 1000PF 10% 500V TYPE2 |
| C115 | 52-05-2468 | FXD CER 0.01UF +80-20% 50V TYPE2 |
| C116 | 54-00-0311 | FXD ELECT 10UF 50V |
| C117 | 52-06-3125 | FXD CER 15PF 10% 500V TYPE1 |
| C118 | 52-06-3051 | FXD CER 5PF 10% 500V TYPE1 |
| C119 | 52-06-2225 | FXD CER 100PF 10% 50V TYPE1 |
| C121 | 52-06-2265 | FXD CER 220PF 10% 50V TYPE1 |
| C122 | 52-06-2265 | FXD CER 220PF 10% 50V TYPE1 |
| C131 | 57-10-1203 | VAR CER 5-20PF |
| C132 | 52-06-3051 | FXD CER 5PF 10% 500V TYPE1 |
| C133 | 52-06-3051 | FXD CER 5PF 10% 500V TYPE1 |
| C151 | - | - |
| C152 | 52-05-2468 | FXD CER 0.01UF +80-20% 50V TYPE2 |
| C153 | 54-00-0311 | FXD ELECT 10UF 50V |
| C171 | 57-10-1223 | VAR CER 8-50PF |
| C172 | 52-05-2468 | FXD CER 0.01UF +80-20% 50V TYPE2 |
| C173 | 52-05-2468 | FXD CER 0.01UF +80-20% 50V TYPE2 |
| C174 | 52-06-2225 | FXD CER 100PF 10% 50V TYPE1 |
| C175 | 52-06-2225 | FXD CER 100PF 10% 50V TYPE1 |
| C177 | 52-06-2215 | FXD CER 82PF 10% 500V TYPE1 |
| C178 | 52-06-2215 | FXD CER 82PF 10% 500V TYPE1 |
| C179 | 52-05-2468 | FXD CER 0.01UF +80-20% 50V TYPE2 |
| C200 | 52-03-3489 | FXD CER 0.01UF +100-0% 500V TYPE2 |
| C201 | 50-96-3590 | FXD PLSTC FILM 0.022UF 20% 630V |
| C202 | 57-10-1191 | VAR CER 3-10PF |
| C203 | 57-10-1181 | VAR CER 3-6PF |
| C204 | 52-06-3165 | FXD CER 33PF 10% 500V TYPE1 |
| C205 | 57-10-1191 | VAR CER 3-10PF |
| C206 | 57-10-1181 | VAR CER 3-6PF |
| C207 | 52-06-2265 | FXD CER 220PF 10% 50V TYPE1 |
| C208 | 52-06-2265 | FXD CER 220PF 10% 50V TYPE1 |
| C211 | 50-87-0510 | FXD PLSTC FILM 2200PF 10% 400V |
| C212 | 52-05-2468 | FXD CER 0.01UF +80-20% 50V TYPE2 |
| C213 | 52-01-3345 | FXD CER 1000PF 10% 500V TYPE2 |
| C214 | 52-01-3345 | FXD CER 1000PF 10% 500V TYPE2 |
| C215 | 52-05-2468 | FXD CER 0.01UF +80-20% 50V TYPE2 |
| C216 | 54-00-0311 | FXD ELECT 10UF 50V |
| C218 | 52-06-3051 | FXD CER 5PF 10% 500V TYPE1 |

For Service Manuals Contact
MAURITRON TECHNICAL SERVICES
8 Cherry Tree Rd, Chinnor
Oxon OX9 4QY
Tel: 01844-351694 Fax: 01844-352554
Email: enquiries@mauritron.co.uk

| REFERENCE DESIGNATOR | KIKUSUI PARTS NO. | DESCRIPTION | |
|----------------------|-------------------|----------------------------------|---------------|
| C219 | 52-06-2225 | FXD CER 100PF 10% 50V TYPE1 | |
| C221 | 52-06-2265 | FXD CER 220PF 10% 50V TYPE1 | |
| C222 | 52-06-2265 | FXD CER 220PF 10% 50V TYPE1 | |
| C231 | 57-10-1203 | VAR CER 5-20PF | |
| C232 | 52-06-3051 | FXD CER 5PF 10% 500V TYPE1 | |
| C233 | 52-06-3051 | FXD CER 5PF 10% 500V TYPE1 | |
| C251 | --- | --- | |
| C252 | 52-05-2468 | FXD CER 0.01UF +80-20% 50V TYPE2 | |
| C271 | 57-10-1223 | VAR CER 8-50PF | |
| C272 | 52-05-2468 | FXD CER 0.01UF +80-20% 50V TYPE2 | |
| C273 | 52-05-2468 | FXD CER 0.01UF +80-20% 50V TYPE2 | |
| C274 | 52-06-2225 | FXD CER 100PF 10% 50V TYPE1 | |
| C275 | 52-06-2225 | FXD CER 100PF 10% 50V TYPE1 | |
| C277 | 52-06-2215 | FXD CER 82PF 10% 500V TYPE1 | |
| C278 | 52-06-2215 | FXD CER 82PF 10% 500V TYPE1 | |
| C279 | 52-05-2468 | FXD CER 0.01UF +80-20% 50V TYPE2 | |
| C282 | 52-05-2468 | FXD CER 0.01UF +80-20% 50V TYPE2 | |
| C301 | 54-00-0121 | FXD ELECT 100UF 25V | |
| C302 | 54-00-0121 | FXD ELECT 100UF 25V | |
| C303 | 52-01-3345 | FXD CER 1000PF 10% 500V TYPE2 | |
| C306 | 52-05-2468 | FXD CER 0.01UF +80-20% 50V TYPE2 | |
| C310 | 52-01-3365 | FXD CER 1500PF 10% 50V TYPE2 | |
| C331 | 57-10-1203 | VAR CER 5-20PF | |
| C332 | 52-06-3051 | FXD CER 5PF 10% 500V TYPE1 | |
| C333 | 50-45-0500 | FXD PLSTC FILM 0.01MF 5% 50V | |
| C334 | 50-45-0500 | FXD PLSTC FILM 0.01MF 5% 50V | |
| C335 | 52-96-1140 | FXD COMP 0.47PF 10% 500V | |
| C336 | 52-96-1140 | FXD COMP 0.47PF 10% 500V | |
| C337 | 50-77-3500 | FXD PLSTC FILM 0.047UF 20% 250V | |
| C338 | 50-77-3500 | FXD PLSTC FILM 0.047UF 20% 250V | |
| C339 | 50-96-3590 | FXD PLSTC FILM 0.022UF 20% 630V | |
| C340 | --- | --- | |
| C341 | 50-96-3590 | FXD PLSTC FILM 0.022UF 20% 630V | |
| C342 | 54-60-1550 | FXD ELECT 1UF 160V | |
| C343 | 52-05-1498 | FXD CER 0.1UF +80-20% 25V TYPE2 | |
| C344 | 50-67-0050 | FXD PLSTC FILM 0.047UF 10% 100V | |
| C345 | * 52-06-3155 | FXD CER 27PF 10% 500V TYPE1 | |
| C346 | * 52-06-3155 | FXD CER 27PF 10% 500V TYPE1 | |
| C347 | 54-00-0311 | FXD ELECT 10UF 50V | |
| C348 | 54-00-0311 | FXD ELECT 10UF 50V | |
| C349 | 52-06-3102 | FXD CER 10PF 10% 500V TYPE1 | |
| C351 | 52-05-2468 | FXD CER 0.01UF +80-20% 50V TYPE2 | |
| C352 | 52-05-2468 | FXD CER 0.01UF +80-20% 50V TYPE2 | |
| C621 | 50-67-0040 | FXD PLSTC FILM 0.022UF 10% 100V | |
| C622 | 50-67-0040 | FXD PLSTC FILM 0.022UF 10% 100V | |
| C623 | 54-60-1620 | FXD ELECT 47UF 200V | |
| C624 | 54-70-1020 | FXD ELECT 2.2UF 250V | |
| C625 | 54-60-1550 | FXD ELECT 1UF 160V | |
| C626 | 54-00-0231 | FXD ELECT 1000UF 35V | |
| C627 | 54-00-0231 | FXD ELECT 1000UF 35V | |
| C628 | 54-00-0114 | FXD ELECT 47UF 25V | |
| L301 | 67-10-0880 | INDUCTOR 2.2UH 20% | |
| L302 | 67-10-0880 | INDUCTOR 2.2UH 20% | |
| S101 | 80-98-0580 | SW ROTARY WITH RV VOLT/DIV | ALPS S21P2YC |
| S102 | 82-70-8231 | LEVER SWITCH | ALPS SLR823-1 |
| S201 | 80-98-0580 | SW ROTARY WITH RV VOLT/DIV | ALPS S21P2YC |
| S202 | 82-70-8231 | LEVER SWITCH | ALPS SLR823-1 |
| S301 | 82-70-8243 | LEVER SWITCH | ALPS SLR824-3 |

A2 ASSEMBLY

| | | | |
|-------|------------|-----------------------|----------------|
| CR401 | 32-11-5880 | DIODE VR=30V IO=120MA | TOSHIBA 1S1588 |
| CR402 | 32-11-5880 | DIODE VR=30V IO=120MA | TOSHIBA 1S1588 |
| CR403 | 32-30-0860 | DIODE VR=30V IO=30MA | HITACHI 1S886 |
| CR404 | 32-11-5880 | DIODE VR=30V IO=120MA | TOSHIBA 1S1588 |
| CR452 | 32-11-5880 | DIODE VR=30V IO=120MA | TOSHIBA 1S1588 |
| CR453 | 32-11-5880 | DIODE VR=30V IO=120MA | TOSHIBA 1S1588 |
| CR454 | 32-92-0033 | ZENER VZ=3.2-3.4V | HITACHI HZ3C-2 |
| CR455 | 32-11-5880 | DIODE VR=30V IO=120MA | TOSHIBA 1S1588 |
| CR456 | 32-11-5880 | DIODE VR=30V IO=120MA | TOSHIBA 1S1588 |
| CR457 | 32-11-5880 | DIODE VR=30V IO=120MA | TOSHIBA 1S1588 |
| CR458 | 32-11-5880 | DIODE VR=30V IO=120MA | TOSHIBA 1S1588 |
| CR459 | 32-11-5880 | DIODE VR=30V IO=120MA | TOSHIBA 1S1588 |
| CR460 | 32-11-5880 | DIODE VR=30V IO=120MA | TOSHIBA 1S1588 |
| CR461 | 32-11-5880 | DIODE VR=30V IO=120MA | TOSHIBA 1S1588 |
| CR462 | 32-11-5880 | DIODE VR=30V IO=120MA | TOSHIBA 1S1588 |

| REFERENCE DESIGNATOR | KIKUSUI PARTS NO. | DESCRIPTION | |
|----------------------|-------------------|----------------------------|---------------------|
| CR463 | 32-30-0860 | DIODE VR=30V IO=30MA | HITACHI 1SS86 |
| CR464 | 32-11-5880 | DIODE VR=30V IO=120MA | TOSHIBA 1S1588 |
| CR465 | 32-92-0056 | ZENER VZ=5.5-5.8V P=0.4W | NEC RD5.6J |
| CR468 | 32-11-5880 | DIODE VR=30V IO=120MA | TOSHIBA 1S1588 |
| CR469 | 32-11-5880 | DIODE VR=30V IO=120MA | TOSHIBA 1S1588 |
| CR501 | 32-30-0860 | DIODE VR=30V IO=30MA | HITACHI 1SS86 |
| CR502 | 32-11-5880 | DIODE VR=30V IO=120MA | TOSHIBA 1S1588 |
| CR503 | 32-30-0830 | DIODE VR=250V IO=200MA | HITACHI 1SS83 |
| CR504 | 32-11-5880 | DIODE VR=30V IO=120MA | TOSHIBA 1S1588 |
| CR651 | 32-92-0056 | ZENER VZ=5.5-5.8V P=0.4W | NEC RD5.6J |
| CR652 | 32-11-5880 | DIODE VR=30V IO=120MA | TOSHIBA 1S1588 |
| CR653 | 32-11-5880 | DIODE VR=30V IO=120MA | TOSHIBA 1S1588 |
| CR654 | 32-11-5880 | DIODE VR=30V IO=120MA | TOSHIBA 1S1588 |
| CR655 | 32-90-1951 | DIODE VR=6KV FAST RECOVERY | SANKEN GHV-06SSN |
| CR656 | 32-90-1951 | DIODE VR=6KV FAST RECOVERY | SANKEN GHV-06SSN |
| CR657 | 32-30-0830 | DIODE VR=250V IO=200MA | HITACHI 1SS83 |
| CR658 | 32-90-1820 | DIODE VR=2KV FAST RECOVERY | HITACHI ERB26-20 |
| CR659 | 32-30-0830 | DIODE VR=250V IO=200MA | HITACHI 1SS83 |
| CR660 | 32-30-0830 | DIODE VR=250V IO=200MA | HITACHI 1SS83 |
| CR661 | 32-30-0830 | DIODE VR=250V IO=200MA | HITACHI 1SS83 |
| CR662 | 32-30-0830 | DIODE VR=250V IO=200MA | HITACHI 1SS83 |
| CR663 | 32-30-0830 | DIODE VR=250V IO=200MA | HITACHI 1SS83 |
| CR664 | 32-30-0830 | DIODE VR=250V IO=200MA | HITACHI 1SS83 |
| CR665 | 32-11-5880 | DIODE VR=30V IO=120MA | TOSHIBA 1S1588 |
| CR666 | 32-92-0022 | ZENER VZ=2.1-2.3V | HITACHI HZ2B-3 |
| CR667 | 32-92-0022 | ZENER VZ=2.1-2.3V | HITACHI HZ2B-3 |
| CR668 | 32-11-5880 | DIODE VR=30V IO=120MA | TOSHIBA 1S1588 |
| CR669 | 32-11-5880 | DIODE VR=30V IO=120MA | TOSHIBA 1S1588 |
| Q401 | 30-10-8381 | TR SI PNP | MATSUSHITA 2SA838-B |
| Q402 | 30-10-8381 | TR SI PNP | MATSUSHITA 2SA838-B |
| Q403 | 31-20-1073 | FET | SONY 2SK107-3 |
| Q404 | 30-31-9071 | TR SI NPN | HITACHI 2SC1907 |
| Q405 | 30-31-9071 | TR SI NPN | HITACHI 2SC1907 |
| Q406 | 30-10-8441 | TR SI PNP | HITACHI 2SA844-D |
| Q407 | 30-10-8441 | TR SI PNP | HITACHI 2SA844-D |
| Q408 | 30-10-8441 | TR SI PNP | HITACHI 2SA844-D |
| Q409 | 30-10-8441 | TR SI PNP | HITACHI 2SA844-D |
| Q410 | 31-20-1171 | FET | TOSHIBA 2SK117-BL |
| Q411 | 30-11-0151 | TR SI PNP | TOSHIBA 2SA1015-Y |
| Q412 | 30-10-8381 | TR SI PNP | MATSUSHITA 2SA838-B |
| Q413 | 30-31-9071 | TR SI NPN | HITACHI 2SC1907 |
| Q415 | 30-31-9071 | TR SI NPN | HITACHI 2SC1907 |
| Q416 | 30-10-8441 | TR SI PNP | HITACHI 2SA844-D |
| Q417 | 30-31-9071 | TR SI NPN | HITACHI 2SC1907 |
| Q418 | 30-30-9451 | TR SI NPN | NEC 2SC945-Q |
| Q419 | 30-10-8441 | TR SI PNP | HITACHI 2SA844-D |
| Q420 | 30-10-8441 | TR SI PNP | HITACHI 2SA844-D |
| Q421 | 30-30-9451 | TR SI NPN | NEC 2SC945-Q |
| Q422 | 30-30-9451 | TR SI NPN | NEC 2SC945-Q |
| Q423 | 30-10-8441 | TR SI PNP | HITACHI 2SA844-D |
| Q424 | 30-31-8431 | TR SI NPN | NEC 2SC1843-E |
| Q425 | 31-20-1171 | FET | TOSHIBA 2SK117-BL |
| Q426 | 31-20-1171 | FET | TOSHIBA 2SK117-BL |
| Q427 | 30-10-8441 | TR SI PNP | HITACHI 2SA844-D |
| Q428 | 30-30-9451 | TR SI NPN | NEC 2SC945-Q |
| Q429 | 30-10-8441 | TR SI PNP | HITACHI 2SA844-D |
| Q430 | 30-10-8441 | TR SI PNP | HITACHI 2SA844-D |
| Q431 | 30-30-9451 | TR SI NPN | NEC 2SC945-Q |
| Q501 | 30-11-0151 | TR SI PNP | TOSHIBA 2SA1015-Y |
| Q502 | 30-11-0151 | TR SI PNP | TOSHIBA 2SA1015-Y |
| Q503 | 30-30-9451 | TR SI NPN | NEC 2SC945-Q |
| Q504 | 30-30-9451 | TR SI NPN | NEC 2SC945-Q |
| Q505 | 30-31-9071 | TR SI NPN | HITACHI 2SC1907 |
| Q506 | 30-31-9071 | TR SI NPN | HITACHI 2SC1907 |
| Q507 | 30-31-9071 | TR SI NPN | HITACHI 2SC1907 |
| Q508 | 30-10-8381 | TR SI PNP | MATSUSHITA 2SA838-B |
| Q509 | 30-20-6481 | TR SI PNP | HITACHI 2SB648A |
| Q510 | 30-40-6681 | TR SI NPN | HITACHI 2SD668A-C |
| Q511 | 30-40-6681 | TR SI NPN | HITACHI 2SD668A-C |
| Q512 | 30-20-6481 | TR SI PNP | HITACHI 2SB648A |
| Q651 | 30-40-8802 | TR SI NPN | NEC 2SD880-Y |
| Q652 | 30-10-8441 | TR SI PNP | HITACHI 2SA844-D |
| Q654 | 30-31-9071 | TR SI NPN | HITACHI 2SC1907 |
| Q655 | 30-31-9071 | TR SI NPN | HITACHI 2SC1907 |
| Q656 | 30-32-3710 | TR SI NPN | NEC 2SC2371-L |
| Q657 | 30-32-3710 | TR SI NPN | NEC 2SC2371-L |

For Service Manuals Contact
MAURITRON TECHNICAL SERVICES
8 Cherry Tree Rd, Chinnor
Oxon OX9 4QY
Tel: 01844-351694 Fax: 01844-352554
Email: enquiries@mauritron.co.uk

| REFERENCE DESIGNATOR | KIKUSUI PARTS NO. | DESCRIPTION | |
|----------------------|-------------------|------------------------------|-------------------|
| Q658 | 30-32-3710 | TR SI NFN | NEC 29C2371-L |
| Q659 | 30-32-3710 | TR SI NFN | NEC 29C2371-L |
| Q660 | 31-20-1171 | FET | TOSHIBA 29K117-BL |
| U401 | 35-70-0001 | QUAD 2-INPUT POSI-NAND | T.I SN74LS00N |
| U402 | 35-70-1121 | DUAL J-K F-F | T.I SN74LS112N |
| U403 | 34-00-0215 | J-FET INPUT OPEAMP | N.S LF13741N |
| U404 | 34-69-0030 | TRIPLE 2-CHANNEL MULTIPLEXER | TOSHIBA TC4053BP |
| U651 | 34-00-0215 | J-FET INPUT OPEAMP | N.S LF13741N |
| R401 | 40-27-0472 | FXD C FILM | 47 OHM 5% 1/4W |
| R402 | 42-72-2100 | FXD M FILM | 1K OHM 1% 1/4W |
| R403 | 40-27-2222 | FXD C FILM | 2.2K OHM 5% 1/4W |
| R404 | 40-27-2122 | FXD C FILM | 1.2K OHM 5% 1/4W |
| R405 | 40-27-2222 | FXD C FILM | 2.2K OHM 5% 1/4W |
| R406 | 40-27-2332 | FXD C FILM | 3.3K OHM 5% 1/4W |
| R407 | 40-27-0472 | FXD C FILM | 47 OHM 5% 1/4W |
| R408 | 40-27-3472 | FXD C FILM | 47K OHM 5% 1/4W |
| R409 | 42-74-5100 | FXD M FILM | 1M OHM 1% 1/2W |
| R410 | 40-27-3102 | FXD C FILM | 10K OHM 5% 1/4W |
| R411 | 40-27-2152 | FXD C FILM | 1.5K OHM 5% 1/4W |
| R412 | 40-27-1562 | FXD C FILM | 560 OHM 5% 1/4W |
| R413 | 40-27-1562 | FXD C FILM | 560 OHM 5% 1/4W |
| R414 | 40-27-0682 | FXD C FILM | 68 OHM 5% 1/4W |
| R415 | 40-27-2392 | FXD C FILM | 3.9K OHM 5% 1/4W |
| R416 | 40-27-2392 | FXD C FILM | 3.9K OHM 5% 1/4W |
| R417 | 40-27-1682 | FXD C FILM | 680 OHM 5% 1/4W |
| R418 | 40-27-1682 | FXD C FILM | 680 OHM 5% 1/4W |
| R419 | 40-27-1682 | FXD C FILM | 680 OHM 5% 1/4W |
| R420 | 40-27-1682 | FXD C FILM | 680 OHM 5% 1/4W |
| R421 | 40-27-4102 | FXD C FILM | 100K OHM 5% 1/4W |
| R422 | 40-27-4102 | FXD C FILM | 100K OHM 5% 1/4W |
| R423 | 40-27-2222 | FXD C FILM | 2.2K OHM 5% 1/4W |
| R424 | 40-27-3222 | FXD C FILM | 22K OHM 5% 1/4W |
| R425 | 40-27-3102 | FXD C FILM | 10K OHM 5% 1/4W |
| R427 | 40-27-3102 | FXD C FILM | 10K OHM 5% 1/4W |
| R428 | 40-27-0332 | FXD C FILM | 33 OHM 5% 1/4W |
| R429 | 40-27-1562 | FXD C FILM | 560 OHM 5% 1/4W |
| R431 | 40-27-3102 | FXD C FILM | 10K OHM 5% 1/4W |
| R432 | 40-27-2102 | FXD C FILM | 1K OHM 5% 1/4W |
| R433 | 40-27-4472 | FXD C FILM | 470K OHM 5% 1/4W |
| R434 | 40-27-4472 | FXD C FILM | 470K OHM 5% 1/4W |
| R435 | 40-27-1392 | FXD C FILM | 390 OHM 5% 1/4W |
| R436 | 40-27-1102 | FXD C FILM | 100 OHM 5% 1/4W |
| R437 | 40-27-1272 | FXD C FILM | 270 OHM 5% 1/4W |
| R438 | 40-27-1102 | FXD C FILM | 100 OHM 5% 1/4W |
| R440 | 40-27-2102 | FXD C FILM | 1K OHM 5% 1/4W |
| R441 | 40-27-2222 | FXD C FILM | 2.2K OHM 5% 1/4W |
| R442 | 40-27-8472 | FXD C FILM | 4.7 OHM 5% 1/4W |
| R443 | 40-27-3472 | FXD C FILM | 47K OHM 5% 1/4W |
| R451 | - | - | - |
| R452 | 40-27-1332 | FXD C FILM | 330 OHM 5% 1/4W |
| R453 | 40-27-0222 | FXD C FILM | 22 OHM 5% 1/4W |
| R454 | 40-27-3472 | FXD C FILM | 47K OHM 5% 1/4W |
| R455 | 40-27-2182 | FXD C FILM | 1.8K OHM 5% 1/4W |
| R456 | 40-27-3102 | FXD C FILM | 10K OHM 5% 1/4W |
| R458 | 40-27-3102 | FXD C FILM | 10K OHM 5% 1/4W |
| R459 | 40-27-2562 | FXD C FILM | 5.6K OHM 5% 1/4W |
| R460 | 40-27-3472 | FXD C FILM | 47K OHM 5% 1/4W |
| R461 | 42-72-3220 | FXD M FILM | 22K OHM 1% 1/4W |
| R462 | 42-72-3330 | FXD M FILM | 33K OHM 1% 1/4W |
| R463 | 40-27-2272 | FXD C FILM | 2.7K OHM 5% 1/4W |
| R464 | 40-27-2472 | FXD C FILM | 4.7K OHM 5% 1/4W |
| R466 | 40-27-2102 | FXD C FILM | 1K OHM 5% 1/4W |
| R467 | 40-27-0472 | FXD C FILM | 47 OHM 5% 1/4W |
| R468 | 40-27-2222 | FXD C FILM | 2.2K OHM 5% 1/4W |
| R469 | 40-27-3102 | FXD C FILM | 10K OHM 5% 1/4W |
| R470 | 40-27-1822 | FXD C FILM | 820 OHM 5% 1/4W |
| R471 | 40-27-3562 | FXD C FILM | 56K OHM 5% 1/4W |
| R472 | 40-27-2222 | FXD C FILM | 2.2K OHM 5% 1/4W |
| R473 | 40-27-2122 | FXD C FILM | 1.2K OHM 5% 1/4W |
| R474 | * | - | - |
| R475 | 40-27-2392 | FXD C FILM | 3.9K OHM 5% 1/4W |
| R476 | 40-27-3182 | FXD C FILM | 18K OHM 5% 1/4W |
| R477 | 40-27-1222 | FXD C FILM | 220 OHM 5% 1/4W |
| R478 | 42-72-2220 | FXD M FILM | 2.2K OHM 1% 1/4W |
| R479 | 40-27-4472 | FXD C FILM | 470K OHM 5% 1/4W |

| REFERENCE DESIGNATOR | KIKUSUI PARTS NO. | DESCRIPTION |
|----------------------|-------------------|-----------------------------|
| R480 | 40-27-3102 | FXD C FILM 10K OHM 5% 1/4W |
| R481 | 40-27-3332 | FXD C FILM 33K OHM 5% 1/4W |
| R482 | 40-27-3102 | FXD C FILM 10K OHM 5% 1/4W |
| R483 | 40-27-2472 | FXD C FILM 4.7K OHM 5% 1/4W |
| R484 | 42-72-2160 | FXD M FILM 1.6K OHM 1% 1/4W |
| R485 | 40-27-4102 | FXD C FILM 100K OHM 5% 1/4W |
| R486 | 40-27-2332 | FXD C FILM 3.3K OHM 5% 1/4W |
| R487 | 40-27-0102 | FXD C FILM 10 OHM 5% 1/4W |
| R488 | 40-27-0102 | FXD C FILM 10 OHM 5% 1/4W |
| R489 | 40-27-0102 | FXD C FILM 10 OHM 5% 1/4W |
| R491 | 42-24-0231 | FXD M GLAZE 5M OHM 1% 0.31W |
| R492 | 42-74-5100 | FXD M FILM 1M OHM 1% 1/2W |
| R493 | 44-04-0010 | FXD M GLAZE R-NETWORK |
| R494 | 42-72-2390 | FXD M FILM 3.9K OHM 1% 1/4W |
| R495 | 42-72-1470 | FXD M FILM 470 OHM 1% 1/4W |
| R496 | 40-27-3102 | FXD C FILM 10K OHM 5% 1/4W |
| R498 | 40-27-1562 | FXD C FILM 560 OHM 5% 1/4W |
| R499 | 40-27-1102 | FXD C FILM 100 OHM 5% 1/4W |
| R501 | 40-27-2682 | FXD C FILM 6.8K OHM 5% 1/4W |
| R502 | 40-27-1472 | FXD C FILM 470 OHM 5% 1/4W |
| R503 | 42-72-0560 | FXD M FILM 56 OHM 1% 1/4W |
| R504 | 40-27-2562 | FXD C FILM 5.6K OHM 5% 1/4W |
| R505 | 40-27-2562 | FXD C FILM 5.6K OHM 5% 1/4W |
| R506 | 40-27-2562 | FXD C FILM 5.6K OHM 5% 1/4W |
| R507 | 40-27-2562 | FXD C FILM 5.6K OHM 5% 1/4W |
| R508 | 42-72-2100 | FXD M FILM 1K OHM 1% 1/4W |
| R509 | 42-72-2100 | FXD M FILM 1K OHM 1% 1/4W |
| R510 | 42-72-2100 | FXD M FILM 1K OHM 1% 1/4W |
| R511 | 42-72-2120 | FXD M FILM 1.2K OHM 1% 1/4W |
| R512 | 40-27-1332 | FXD C FILM 330 OHM 5% 1/4W |
| R513 | 40-27-1332 | FXD C FILM 330 OHM 5% 1/4W |
| R514 | 40-27-3102 | FXD C FILM 10K OHM 5% 1/4W |
| R515 | 40-27-4102 | FXD C FILM 100K OHM 5% 1/4W |
| R516 | 40-27-2222 | FXD C FILM 2.2K OHM 5% 1/4W |
| R517 | 40-27-2222 | FXD C FILM 2.2K OHM 5% 1/4W |
| R518 | 42-72-4100 | FXD M FILM 100K OHM 1% 1/4W |
| R519 | 42-72-4100 | FXD M FILM 100K OHM 1% 1/4W |
| R520 | 40-27-4102 | FXD C FILM 100K OHM 5% 1/4W |
| R521 | 40-27-4102 | FXD C FILM 100K OHM 5% 1/4W |
| R522 | 40-27-2152 | FXD C FILM 1.5K OHM 5% 1/4W |
| R523 | 40-27-1332 | FXD C FILM 330 OHM 5% 1/4W |
| R524 | 40-27-2152 | FXD C FILM 1.5K OHM 5% 1/4W |
| R525 | 40-27-1332 | FXD C FILM 330 OHM 5% 1/4W |
| R526 | 40-27-0472 | FXD C FILM 47 OHM 5% 1/4W |
| R527 | 40-27-0472 | FXD C FILM 47 OHM 5% 1/4W |
| R528 | * | * |
| R651 | 42-72-2820 | FXD M FILM 8.2K OHM 1% 1/4W |
| R652 | 42-72-3120 | FXD M FILM 12K OHM 1% 1/4W |
| R653 | * | * |
| R654 | 42-72-3680 | FXD M FILM 68K OHM 1% 1/4W |
| R655 | 40-27-2102 | FXD C FILM 1K OHM 5% 1/4W |
| R657 | 44-91-0010 | FXD M OXIDE 1 OHM 5% 1W |
| R658 | 40-27-2472 | FXD C FILM 4.7K OHM 5% 1/4W |
| R659 | 40-27-1472 | FXD C FILM 470 OHM 5% 1/4W |
| R660 | 40-37-3221 | FXD C FILM 22K OHM 5% 1/2W |
| R661 | 40-37-5221 | FXD C FILM 2.2M OHM 5% 1/2W |
| R662 | 42-44-0300 | FXD M GLAZE 10M OHM 1% 2.5W |
| R663 | 40-27-2102 | FXD C FILM 1K OHM 5% 1/4W |
| R664 | 40-27-3102 | FXD C FILM 10K OHM 5% 1/4W |
| R665 | 40-37-5221 | FXD C FILM 2.2M OHM 5% 1/2W |
| R666 | 40-37-6101 | FXD C FILM 10M OHM 5% 1/2W |
| R667 | 40-37-6101 | FXD C FILM 10M OHM 5% 1/2W |
| R668 | 40-27-2332 | FXD C FILM 3.3K OHM 5% 1/4W |
| R669 | 40-37-5151 | FXD C FILM 1.5M OHM 5% 1/2W |
| R670 | 40-27-3102 | FXD C FILM 10K OHM 5% 1/4W |
| R671 | 40-27-4102 | FXD C FILM 100K OHM 5% 1/4W |
| R673 | 40-27-3102 | FXD C FILM 10K OHM 5% 1/4W |
| R674 | 40-37-6101 | FXD C FILM 10M OHM 5% 1/2W |
| R675 | 40-37-6101 | FXD C FILM 10M OHM 5% 1/2W |
| R676 | 40-37-5151 | FXD C FILM 1.5M OHM 5% 1/2W |
| R677 | 40-27-1102 | FXD C FILM 100 OHM 5% 1/4W |
| R678 | 40-27-1102 | FXD C FILM 100 OHM 5% 1/4W |
| R679 | 40-27-1102 | FXD C FILM 100 OHM 5% 1/4W |
| R680 | 40-27-4472 | FXD C FILM 470K OHM 5% 1/4W |
| R681 | 40-27-2182 | FXD C FILM 1.8K OHM 5% 1/4W |
| R683 | 40-27-2332 | FXD C FILM 3.3K OHM 5% 1/4W |
| R684 | 40-27-2222 | FXD C FILM 2.2K OHM 5% 1/4W |

KIKUSUI SB109011

For Service Manuals Contact
MAURITRON TECHNICAL SERVICES
8 Cherry Tree Rd, Chinnor
Oxon OX9 4QY
Tel: 01844-351694 Fax: 01844-352554
Email: enquiries@mauritron.co.uk

| REFERENCE DESIGNATOR | KIKUSUI PARTS NO. | DESCRIPTION |
|----------------------|-------------------|-------------------------------------|
| R685 | 40-27-1102 | FXD C FILM 100 OHM 5% 1/4W |
| R686 | 40-27-1222 | FXD C FILM 220 OHM 5% 1/4W |
| R687 | 40-27-2562 | FXD C FILM 5.6K OHM 5% 1/4W |
| R688 | 40-27-1332 | FXD C FILM 330 OHM 5% 1/4W |
| R689 | 40-27-2472 | FXD C FILM 4.7K OHM 5% 1/4W |
| R690 | 40-37-3471 | FXD C FILM 47K OHM 5% 1/2W |
| R691 | 40-37-3471 | FXD C FILM 47K OHM 5% 1/2W |
| R692 | 40-37-3471 | FXD C FILM 47K OHM 5% 1/2W |
| R693 | 40-27-1682 | FXD C FILM 680 OHM 5% 1/4W |
| R694 | 40-27-1682 | FXD C FILM 680 OHM 5% 1/4W |
| R695 | 40-37-3471 | FXD C FILM 47K OHM 5% 1/2W |
| R696 | 40-27-1102 | FXD C FILM 100 OHM 5% 1/4W |
| R697 | 40-27-4102 | FXD C FILM 100K OHM 5% 1/4W |
| R698 | * 40-27-3392 | FXD C FILM 39K OHM 5% 1/4W |
| R699 | 40-27-3562 | FXD C FILM 56K OHM 5% 1/4W |
| R1401 | 40-27-2102 | FXD C FILM 1K OHM 5% 1/4W |
| R1403 | 40-27-2102 | FXD C FILM 1K OHM 5% 1/4W |
| R1404 | 40-27-4472 | FXD C FILM 470K OHM 5% 1/4W |
| R1405 | 40-27-2102 | FXD C FILM 1K OHM 5% 1/4W |
| R1652 | 40-27-3182 | FXD C FILM 18K OHM 5% 1/4W |
| R1654 | 40-27-2332 | FXD C FILM 3.3K OHM 5% 1/4W |
| RV401 | 48-33-2500 | VAR M FILM 5K OHM |
| RV404 | 48-33-4500 | VAR M FILM 500K OHM |
| RV405 | 48-33-3100 | VAR M FILM 10K OHM |
| RV651 | 48-26-5220 | VAR M GLAZE 2.2M OHM |
| RV652 | 48-33-4100 | VAR M FILM 100K OHM |
| V653 | 48-33-3200 | VAR M FILM 20K OHM |
| C401 | 52-05-2468 | FXD CER 0.01UF +80-20% 50V TYPE2 |
| C402 | 50-67-0040 | FXD PLSTC FILM 0.022UF 10% 100V |
| C403 | 52-06-3185 | FXD CER 47PF 10% 500V TYPE1 |
| C404 | 52-06-3185 | FXD CER 47PF 10% 500V TYPE1 |
| C405 | * 52-06-3185 | FXD CER 47PF 10% 500V TYPE1 |
| C406 | 54-00-0114 | FXD ELECT 47UF 25V |
| C407 | 54-00-0114 | FXD ELECT 47UF 25V |
| C408 | 54-00-0311 | FXD ELECT 10UF 50V |
| C409 | 54-00-0311 | FXD ELECT 10UF 50V |
| C410 | 54-00-0311 | FXD ELECT 10UF 50V |
| C411 | * - - - | - - - |
| C431 | 55-37-2050 | FXD TANT ELECT 1UF 35V |
| C432 | 54-00-0311 | FXD ELECT 10UF 50V |
| C433 | 50-67-0030 | FXD PLSTC FILM 0.01UF 10% 100V |
| C451 | 52-06-3185 | FXD CER 47PF 10% 500V TYPE1 |
| C452 | 54-00-0114 | FXD ELECT 47UF 25V |
| C454 | 52-01-3345 | FXD CER 1000PF 10% 500V TYPE2 |
| C455 | 52-06-3185 | FXD CER 47PF 10% 500V TYPE1 |
| C456 | 54-00-0311 | FXD ELECT 10UF 50V |
| C457 | 54-00-0114 | FXD ELECT 47UF 25V |
| C458 | 52-06-2225 | FXD CER 100PF 10% 50V TYPE1 |
| C459 | 50-65-0530 | FXD M PLSTC FILM 1000PF 5% 100V |
| C460 | 50-65-0540 | FXD M PLSTC FILM 1UF 5% 100V |
| C461 | 54-00-0114 | FXD ELECT 47UF 25V |
| C462 | 52-05-2468 | FXD CER 0.01UF +80-20% 50V TYPE2 |
| C463 | 54-00-0311 | FXD ELECT 10UF 50V |
| C464 | 54-00-0311 | FXD ELECT 10UF 50V |
| C465 | 52-06-3125 | FXD CER 15PF 10% 500V TYPE1 |
| C467 | 52-01-3345 | FXD CER 1000PF 10% 500V TYPE2 |
| C468 | 50-67-0030 | FXD PLSTC FILM 0.01UF 10% 100V |
| C469 | 52-05-2468 | FXD CER 0.01UF +80-20% 50V TYPE2 |
| C503 | 52-03-3469 | FXD CER 0.01UF +100-0% 500V TYPE2 |
| C504 | 52-03-3469 | FXD CER 0.01UF +100-0% 500V TYPE2 |
| C506 | 52-03-3469 | FXD CER 0.01UF +100-0% 500V TYPE2 |
| C507 | 52-03-3469 | FXD CER 0.01UF +100-0% 500V TYPE2 |
| C508 | 54-00-0311 | FXD ELECT 10UF 50V |
| C509 | 52-03-3469 | FXD CER 0.01UF +100-0% 500V TYPE2 |
| C510 | 54-00-0311 | FXD ELECT 10UF 50V |
| C511 | * - - - | - - - |
| C651 | 54-00-0311 | FXD ELECT 10UF 50V |
| C652 | 54-00-0311 | FXD ELECT 10UF 50V |
| C653 | 52-01-3365 | FXD CER 1500PF 10% 50V TYPE2 |
| C654 | 50-67-0040 | FXD PLSTC FILM 0.022UF 10% 100V |
| C655 | 54-00-0312 | FXD ELECT 22UF 50V |
| C656 | 55-37-2050 | FXD TANT ELECT 1UF 35V |
| C657 | 52-98-1000 | FXD CER 4700PF +80-20% 3.15KV TYPE1 |
| C658 | 52-98-1000 | FXD CER 4700PF +80-20% 3.15KV TYPE1 |

| REFERENCE DESIGNATOR | KIKUSUI PARTS NO. | DESCRIPTION | |
|----------------------|-------------------|-----------------------------|----------------------|
| C659 | 52-98-1000 | FXD CER 4700PF | +80-20% 3.15KV TYPE1 |
| C660 | 52-98-1010 | FXD CER 1000PF | +80-20% 6.3KV TYPE1 |
| C661 | 52-98-1010 | FXD CER 1000PF | +80-20% 6.3KV TYPE1 |
| C662 | 52-98-1010 | FXD CER 1000PF | +80-20% 6.3KV TYPE1 |
| C663 | 52-98-1010 | FXD CER 1000PF | +80-20% 6.3KV TYPE1 |
| C664 | 52-03-3469 | FXD CER 0.01UF | +100-0% 500V TYPE2 |
| C665 | 52-98-1010 | FXD CER 1000PF | +80-20% 6.3KV TYPE1 |
| C666 | 52-98-1010 | FXD CER 1000PF | +80-20% 6.3KV TYPE1 |
| C667 | 52-98-1000 | FXD CER 4700PF | +80-20% 3.15KV TYPE1 |
| C668 | 52-08-5145 | FXD CER 22PF | 10% 2KV TYPE1 |
| C669 | 50-67-0040 | FXD PLSTC FILM | 0.022UF 10% 100V |
| C681 | 52-05-2468 | FXD CER 0.01UF | +80-20% 50V TYPE2 |
| C682 | 52-06-2265 | FXD CER 220PF | 10% 50V TYPE1 |
| C683 | 54-00-0311 | FXD ELECT 10UF | 50V |
| C684 | 54-00-0311 | FXD ELECT 10UF | 50V |
| C685 | 52-03-3469 | FXD CER 0.01UF | +100-0% 500V TYPE2 |
| C686 | 54-00-0311 | FXD ELECT 10UF | 50V |
| C687 | 52-03-3469 | FXD CER 0.01UF | +100-0% 500V TYPE2 |
| C688 | 52-05-2468 | FXD CER 0.01UF | +80-20% 50V TYPE2 |
| C689 | 52-05-2468 | FXD CER 0.01UF | +80-20% 50V TYPE2 |
| DS651 | 23-70-0000 | LAMP NEON | |
| DS652 | 23-70-0000 | LAMP NEON | |
| L650 | 67-10-0890 | INDUCTOR 100UH | 10% |
| S401 | 82-70-5242 | LEVER SWITCH | ALPS SLR524-2 |
| S402 | 82-70-5242 | LEVER SWITCH | ALPS SLR524-2 |
| S403 | 82-70-5222 | PUSH SWITCH | ALPS SLR522-2 |
| S406 | 80-98-0470 | SW ROTARY WITH RV SWEEP/DIV | ALPS S21P2421 |
| T651 | 63-92-0130 | CONVERTOR TRANS | KIKUSUI S810115 |
| A4 ASSEMBLY | | | |
| CR1601 | 32-92-0360 | ZENER VZ=35.3-36.8V | HITACHI HZ36L-2 |
| CR1602 | 32-92-0360 | ZENER VZ=35.3-36.8V | HITACHI HZ36L-2 |
| CR1603 | 32-92-0360 | ZENER VZ=35.3-36.8V | HITACHI HZ36L-2 |
| CR1604 | 32-92-0360 | ZENER VZ=35.3-36.8V | HITACHI HZ36L-2 |
| CR1605 | 37-00-0060 | LAMP LED GREEN | TOSHIBA TLG-105 |
| Q1601 | 30-31-8461 | TR SI NPN | MATSUSHITA 2SC1846-R |
| Q1602 | 30-31-8461 | TR SI NPN | MATSUSHITA 2SC1846-R |
| U1601 | 35-60-0000 | QUAD 2-INPUT NAND GATES | TOSHIBA TC4011BF |
| R1601 | * 40-27-4102 | FXD C FILM 100K | OHM 5% 1/4W |
| R1602 | 40-27-3102 | FXD C FILM 10K | OHM 5% 1/4W |
| R1603 | 40-27-3102 | FXD C FILM 10K | OHM 5% 1/4W |
| R1604 | 40-27-4102 | FXD C FILM 100K | OHM 5% 1/4W |
| R1605 | 40-27-4102 | FXD C FILM 100K | OHM 5% 1/4W |
| R1606 | 40-27-4222 | FXD C FILM 220K | OHM 5% 1/4W |
| R1607 | 40-27-4472 | FXD C FILM 470K | OHM 5% 1/4W |
| R1608 | 40-27-4472 | FXD C FILM 470K | OHM 5% 1/4W |
| R1609 | 40-27-1472 | FXD C FILM 470 | OHM 5% 1/4W |
| R1610 | 42-72-3100 | FXD M FILM 10K | OHM 1% 1/4W |
| R1611 | * 40-27-4102 | FXD C FILM 100K | OHM 5% 1/4W |
| R1612 | 42-72-2200 | FXD M FILM 2K | OHM 1% 1/4W |
| R1613 | 40-27-0102 | FXD C FILM 10 | OHM 5% 1/4W |
| R1614 | 40-27-1682 | FXD C FILM 680 | OHM 5% 1/4W |
| R1615 | 40-27-1102 | FXD C FILM 100 | OHM 5% 1/4W |
| R1616 | 40-27-1562 | FXD C FILM 560 | OHM 5% 1/4W |
| RV1601 | 45-44-3100 | VAR C COMP 10K | OHM |
| RV1603 | 45-44-4200 | VAR C COMP 200K | OHM |
| RV1604 | 45-43-2200 | VAR M GLAZE 2K | OHM |
| RV1605 | 45-44-3100 | VAR C COMP 10K | OHM |
| C1605 | 50-45-0500 | FXD PLSTC FILM 0.01MF | 5% 50V |
| C1606 | 50-45-0500 | FXD PLSTC FILM 0.01MF | 5% 50V |
| C1607 | 52-06-3051 | FXD CER 5PF | 10% 500V TYPE1 |
| C1608 | 52-01-3345 | FXD CER 1000PF | 10% 500V TYPE2 |
| C1609 | 54-00-0114 | FXD ELECT 47UF | 25V |
| C1610 | 52-03-3469 | FXD CER 0.01UF | +100-0% 500V TYPE2 |
| DS1601 | 23-44-0000 | LAMP 14V 80MA | |
| DS1602 | 23-44-0000 | LAMP 14V 80MA | |
| B ASSEMBLY | | | |
| CR409 | 37-00-0082 | LAMP LED RED | TOSHIBA TLR102KW |

For Service Manuals Contact
MAURITRON TECHNICAL SERVICES
8 Cherry Tree Rd, Chinnor
Oxon OX9 4QY
Tel: 01844-351694 Fax: 01844-352554
Email: enquiries@mauritron.co.uk

| REFERENCE DESIGNATOR | KIKUSUI PARTS NO. | DESCRIPTION | |
|----------------------|-------------------|---------------------------------|------------------|
| CR451 | 32-11-5880 | DIODE VR=30V IO=120MA | TOSHIBA 191588 |
| R101 | 40-27-0472 | FXD C FILM 47 OHM 5% 1/4W | |
| R201 | 40-27-0472 | FXD C FILM 47 OHM 5% 1/4W | |
| R426 | 40-27-2822 | FXD C FILM 8.2K OHM 5% 1/4W | |
| R457 | 40-27-3102 | FXD C FILM 10K OHM 5% 1/4W | |
| R1402 | 40-27-0562 | FXD C FILM 56 OHM 5% 1/4W | |
| RV111 | 45-01-0700 | VAR C COMP 10K OHM WITH SW | |
| RV211 | 45-01-0700 | VAR C COMP 10K OHM WITH SW | |
| RV402 | 45-01-0550 | VAR C COMP 10K/100K OHM B | |
| RV404 | 45-01-0690 | VAR C COMP 10K OHM WITH SW | |
| RV501 | 45-35-3103 | VAR C COMP 10K OHM | |
| C453 | 52-01-3345 | FXD CER 1000PF 10% 500V TYPE2 | |
| C466 | 52-05-1498 | FXD CER 0.1UF +80-20% 25V TYPE2 | |
| C601 | 52-77-1000 | FXD CER 100PF 250VAC | |
| C602 | 52-77-1000 | FXD CER 100PF 250VAC | |
| S404 | 81-03-0270 | PUSH SWITCH | ALPS SUE30 |
| S1601 | 81-01-0270 | PUSH SWITCH | ALPS SIG5F-E |
| T601 | 60-44-0110 | POWER TRANS | KIKUSUI S820041 |
| V601 | 21-16-0601 | CRT | TOSHIBA 150BTB31 |

For Service Manuals Contact
 MAURITRON TECHNICAL SERVICES
 8 Cherry Tree Rd, Chinnor
 Oxon OX9 4QY
 Tel: 01844-351694 Fax: 01844-352554
 Email: enquiries@maurtron.co.uk

REPLACEABLE PARTS FOR COS5021

ABBREVIATIONS

| | |
|---------------|---|
| CER: | CERAMIC |
| C FILM: | CARBON FILM |
| C COMP: | CARBON COMPOSITION |
| CRT: | CATHODE RAY TUBE |
| ELECT: | ELECTROLYTIC |
| FET: | FIELD EFFECT TRANSISTOR |
| FXD: | FIXED |
| LED: | LIGHT EMITTING DIODE |
| M FILM: | METAL FILM |
| M GLAZE: | METAL GLAZE |
| M OX: | METAL OXIDE |
| M PLSTC FILM: | METALLIZED PLASTIC FILM |
| PLSTC FILM: | PLASTIC FILM |
| Si: | SILICON |
| TANT ELECT: | TANTALUM ELECTROLYTIC |
| VAR: | VARIABLE |
| WW: | WIREWOUND |
| *: | OPTIMUM VALUE SELECTED AT FACTORY. AVERAGE VALUE SHOWN. (PART MAY BE OMITTED.) |

REFERENCE KIKUSUI
DESIGNATOR PARTS NO.

DESCRIPTION

A1 ASSEMBLY

| | | | | | | |
|-------|------------|-------|-----------------|----------------|------------|-----------|
| CR101 | 32-11-5880 | DIODE | VR=30V | IO=120MA | TOSHIBA | 1S1588 |
| CR102 | 32-92-0033 | ZENER | VZ=3.2-3.4V | | HITACHI | HZ3C-2 |
| CR103 | 32-11-5880 | DIODE | VR=30V | IO=120MA | TOSHIBA | 1S1588 |
| CR104 | 32-11-5880 | DIODE | VR=30V | IO=120MA | TOSHIBA | 1S1588 |
| CR105 | 32-11-5880 | DIODE | VR=30V | IO=120MA | TOSHIBA | 1S1588 |
| CR106 | 32-11-5880 | DIODE | VR=30V | IO=120MA | TOSHIBA | 1S1588 |
| CR107 | 32-11-5880 | DIODE | VR=30V | IO=120MA | TOSHIBA | 1S1588 |
| CR108 | 32-11-5880 | DIODE | VR=30V | IO=120MA | TOSHIBA | 1S1588 |
| CR201 | 32-92-0033 | ZENER | VZ=3.2-3.4V | | HITACHI | HZ3C-2 |
| CR203 | 32-11-5880 | DIODE | VR=30V | IO=120MA | TOSHIBA | 1S1588 |
| CR204 | 32-11-5880 | DIODE | VR=30V | IO=120MA | TOSHIBA | 1S1588 |
| CR205 | 32-11-5880 | DIODE | VR=30V | IO=120MA | TOSHIBA | 1S1588 |
| CR206 | 32-11-5880 | DIODE | VR=30V | IO=120MA | TOSHIBA | 1S1588 |
| CR207 | 32-11-5880 | DIODE | VR=30V | IO=120MA | TOSHIBA | 1S1588 |
| CR208 | 32-11-5880 | DIODE | VR=30V | IO=120MA | TOSHIBA | 1S1588 |
| CR301 | 32-11-5880 | DIODE | VR=30V | IO=120MA | TOSHIBA | 1S1588 |
| CR302 | 32-11-5880 | DIODE | VR=30V | IO=120MA | TOSHIBA | 1S1588 |
| CR303 | 32-11-5880 | DIODE | VR=30V | IO=120MA | TOSHIBA | 1S1588 |
| CR304 | 32-11-5880 | DIODE | VR=30V | IO=120MA | TOSHIBA | 1S1588 |
| CR305 | 32-11-5880 | DIODE | VR=30V | IO=120MA | TOSHIBA | 1S1588 |
| CR306 | 32-11-5880 | DIODE | VR=30V | IO=120MA | TOSHIBA | 1S1588 |
| CR307 | 32-11-5880 | DIODE | VR=30V | IO=120MA | TOSHIBA | 1S1588 |
| CR308 | 32-11-5880 | DIODE | VR=30V | IO=120MA | TOSHIBA | 1S1588 |
| CR309 | 32-11-5880 | DIODE | VR=30V | IO=120MA | TOSHIBA | 1S1588 |
| CR310 | 32-11-5880 | DIODE | VR=30V | IO=120MA | TOSHIBA | 1S1588 |
| CR311 | 32-92-0022 | ZENER | VZ=2.1-2.3V | | HITACHI | HZ2B-3 |
| CR314 | 32-92-0022 | ZENER | VZ=2.1-2.3V | | HITACHI | HZ2B-3 |
| CR317 | 32-11-5880 | DIODE | VR=30V | IO=120MA | TOSHIBA | 1S1588 |
| CR318 | 32-11-5880 | DIODE | VR=30V | IO=120MA | TOSHIBA | 1S1588 |
| CR319 | 32-11-5880 | DIODE | VR=30V | IO=120MA | TOSHIBA | 1S1588 |
| CR320 | 32-11-5880 | DIODE | VR=30V | IO=120MA | TOSHIBA | 1S1588 |
| CR621 | 32-90-2110 | DIODE | BRIDGE | VRM=400V IO=1A | TOSHIBA | 1G4B42 |
| CR622 | 32-90-2110 | DIODE | BRIDGE | VRM=400V IO=1A | TOSHIBA | 1G4B42 |
| CR623 | 32-11-5880 | DIODE | VR=30V | IO=120MA | TOSHIBA | 1S1588 |
| CR624 | 32-92-0130 | ZENER | VZ=12.41-13.05V | P=0.4W | NEC | RD13J |
| CR625 | 32-92-0130 | ZENER | VZ=12.41-13.05V | P=0.4W | NEC | RD13J |
| CR626 | 32-11-5880 | DIODE | VR=30V | IO=120MA | TOSHIBA | 1S1588 |
| CR627 | 32-92-0056 | ZENER | VZ=5.5-5.8V | P=0.4W | NEC | RD5.6J |
| CR670 | 32-11-5880 | DIODE | VR=30V | IO=120MA | TOSHIBA | 1S1588 |
| Q101 | 31-20-1073 | FET | | | SONY | 2SK107-3 |
| Q102 | 30-30-9451 | TR | SI | NFN | NEC | 2SC945-Q |
| Q103 | 30-10-8441 | TR | SI | PNP | HITACHI | 2SA844-D |
| Q104 | 30-30-9451 | TR | SI | NFN | NEC | 2SC945-Q |
| Q105 | 30-11-2061 | TR | SI | PNP | NEC | 2SA1206-L |
| Q106 | 30-11-2061 | TR | SI | PNP | NEC | 2SA1206-L |
| Q107 | 30-10-8381 | TR | SI | PNP | MATSUSHITA | 2SA838-B |
| Q108 | 30-10-8381 | TR | SI | PNP | MATSUSHITA | 2SA838-B |
| Q109 | 30-31-9071 | TR | SI | NFN | HITACHI | 2SC1907 |
| Q110 | 30-10-8381 | TR | SI | PNP | MATSUSHITA | 2SA838-B |
| Q111 | 30-10-8381 | TR | SI | PNP | MATSUSHITA | 2SA838-B |
| Q201 | 31-20-1073 | FET | | | SONY | 2SK107-3 |
| Q202 | 30-30-9451 | TR | SI | NFN | NEC | 2SC945-Q |
| Q203 | 30-10-8441 | TR | SI | PNP | HITACHI | 2SA844-D |
| Q204 | 30-30-9451 | TR | SI | NFN | NEC | 2SC945-Q |
| Q205 | 30-11-2061 | TR | SI | PNP | NEC | 2SA1206-L |
| Q206 | 30-11-2061 | TR | SI | PNP | NEC | 2SA1206-L |
| Q207 | 30-10-8381 | TR | SI | PNP | MATSUSHITA | 2SA838-B |
| Q208 | 30-10-8381 | TR | SI | PNP | MATSUSHITA | 2SA838-B |
| Q210 | 30-10-8381 | TR | SI | PNP | MATSUSHITA | 2SA838-B |
| Q211 | 30-10-8381 | TR | SI | PNP | MATSUSHITA | 2SA838-B |
| Q212 | 30-10-8381 | TR | SI | PNP | MATSUSHITA | 2SA838-B |
| Q213 | 30-10-8381 | TR | SI | PNP | MATSUSHITA | 2SA838-B |
| Q301 | 30-11-2061 | TR | SI | PNP | NEC | 2SA1206-L |
| Q302 | 30-11-2061 | TR | SI | PNP | NEC | 2SA1206-L |
| Q303 | 30-10-8441 | TR | SI | PNP | HITACHI | 2SA844-D |
| Q304 | 30-10-8441 | TR | SI | PNP | HITACHI | 2SA844-D |
| Q305 | 30-31-9071 | TR | SI | NFN | HITACHI | 2SC1907 |
| Q306 | 30-31-9071 | TR | SI | NFN | HITACHI | 2SC1907 |
| Q307 | 30-31-9071 | TR | SI | NFN | HITACHI | 2SC1907 |
| Q308 | 30-11-2061 | TR | SI | PNP | NEC | 2SA1206-L |
| Q309 | 30-11-2061 | TR | SI | PNP | NEC | 2SA1206-L |
| Q310 | 30-31-9071 | TR | SI | NFN | HITACHI | 2SC1907 |
| Q311 | 30-32-5700 | TR | SI | NFN | NEC | 2SC2570 |
| Q312 | 30-20-6481 | TR | SI | PNP | HITACHI | 2SB648A |
| Q313 | 30-40-6681 | TR | SI | NFN | HITACHI | 2SU668A-C |

For Service Manuals Contact
MAURITRON TECHNICAL SERVICES
8 Cherry Tree Rd, Chinnor
Oxon OX9 4QY
Tel: 01844-351694 Fax: 01844-352554
Email: enquiries@mauratron.co.uk

| REFERENCE DESIGNATOR | KIKUSUI PARTS NO. | DESCRIPTION | |
|----------------------|-------------------|-------------------------|----------------------------|
| Q314 | 30-40-6681 | TR SI NPN | HITACHI 2SD668A-C |
| Q315 | 30-20-6481 | TR SI PNP | HITACHI 2SB648A |
| Q316 | 30-32-5700 | TR SI NPN | NEC 2SC2570 |
| Q603 | 30-20-8611 | TR SI PNP | HITACHI 2SR861-C |
| Q604 | 30-20-8341 | TR SI PNP | TOSHIBA 2SB834-Y |
| Q605 | 30-40-8802 | TR SI NPN | NEC 2SD880-Y |
| Q606 | 30-40-8802 | TR SI NPN | NEC 2SD880-Y |
| QCR101 | 30-31-9071 | TR SI NPN | HITACHI 2SC1907 |
| QCR201 | 30-31-9071 | TR SI NPN | HITACHI 2SC1907 |
| U101 | 34-00-0121 | FET OPEAMP | N.S LF13741N |
| U102 | 30-90-0141 | TRANSISTOR ARRAYS 5 NPN | RCA CA3086 |
| U201 | 34-00-0121 | FET OPEAMP | N.S LF13741N |
| U202 | 30-90-0141 | TRANSISTOR ARRAYS 5 NPN | RCA CA3086 |
| U301 | 35-70-0741 | DUAL D-FLIP FLOP | T.I SN74LS74N |
| U302 | 35-70-0001 | QUAD 2-INPUT POSI-NAND | T.I SN74LS00N |
| U602 | 34-00-0240 | DUAL OPEAMP | NEC UPC4558C |
| U603 | 34-00-0240 | DUAL OPEAMP | NEC UPC4558C |
| R102 | 40-27-0332 | FXD C FILM | 33 OHM 5% 1/4W |
| R103 | 42-74-5100 | FXD M FILM | 1M OHM 1% 1/2W |
| R104 | 42-74-4900 | FXD M FILM | 900K OHM 1% 1/2W |
| R105 | 42-72-4111 | FXD M FILM | 111K OHM 1% 1/4W |
| R106 | 42-74-4990 | FXD M FILM | 990K OHM 1% 1/2W |
| R107 | 42-72-3101 | FXD M FILM | 10.1K OHM 1% 1/4W |
| R108 | 40-27-0222 | FXD C FILM | 22 OHM 5% 1/4W |
| R109 | 40-27-0682 | FXD C FILM | 68 OHM 5% 1/4W |
| R110 | 40-27-0102 | FXD C FILM | 10 OHM 5% 1/4W |
| R111 | 40-37-4471 | FXD C FILM | 470K OHM 5% 1/2W |
| R112 | 40-27-2102 | FXD C FILM | 1K OHM 5% 1/4W |
| R113 | 40-27-2562 | FXD C FILM | 5.6K OHM 5% 1/4W |
| R114 | 40-27-2102 | FXD C FILM | 1K OHM 5% 1/4W |
| R115 | 40-27-1102 | FXD C FILM | 100 OHM 5% 1/4W |
| R116 | 40-27-1682 | FXD C FILM | 680 OHM 5% 1/4W |
| R117 | 40-27-2392 | FXD C FILM | 3.9K OHM 5% 1/4W |
| R118 | 40-27-2822 | FXD C FILM | 8.2K OHM 5% 1/4W |
| R119 | 40-27-2562 | FXD C FILM | 5.6K OHM 5% 1/4W |
| R120 | 40-27-2122 | FXD C FILM | 1.2K OHM 5% 1/4W |
| R121 | 40-27-0102 | FXD C FILM | 10 OHM 5% 1/4W |
| R122 | 40-27-0102 | FXD C FILM | 10 OHM 5% 1/4W |
| R123 | 44-04-0000 | FXD M GLAZE | R-NETWORK KIKUSUI S8109001 |
| R124 | 38-00-0000 | THERMISTER | 250 OHM |
| R131 | 40-27-1102 | FXD C FILM | 100 OHM 5% 1/4W |
| R132 | 40-27-1122 | FXD C FILM | 120 OHM 5% 1/4W |
| R133 | 40-27-1122 | FXD C FILM | 120 OHM 5% 1/4W |
| R134 | 40-27-2562 | FXD C FILM | 5.6K OHM 5% 1/4W |
| R135 | 40-27-2562 | FXD C FILM | 5.6K OHM 5% 1/4W |
| R136 | 40-27-1682 | FXD C FILM | 680 OHM 5% 1/4W |
| R137 | 40-27-3472 | FXD C FILM | 47K OHM 5% 1/4W |
| R138 | 40-27-1102 | FXD C FILM | 100 OHM 5% 1/4W |
| R139 | 42-72-1470 | FXD M FILM | 470 OHM 1% 1/4W |
| R140 | 40-27-1272 | FXD C FILM | 270 OHM 5% 1/4W |
| R141 | 42-72-1470 | FXD M FILM | 470 OHM 1% 1/4W |
| R142 | 42-72-0560 | FXD M FILM | 56 OHM 1% 1/4W |
| R144 | 42-72-0560 | FXD M FILM | 56 OHM 1% 1/4W |
| R145 | 40-27-3472 | FXD C FILM | 47K OHM 5% 1/4W |
| R146 | 40-27-0272 | FXD C FILM | 27 OHM 5% 1/4W |
| R147 | 40-27-0272 | FXD C FILM | 27 OHM 5% 1/4W |
| R148 | 42-72-1680 | FXD M FILM | 680 OHM 1% 1/4W |
| R149 | 42-72-1680 | FXD M FILM | 680 OHM 1% 1/4W |
| R150 | 40-27-0222 | FXD C FILM | 22 OHM 5% 1/4W |
| R151 | 40-27-0222 | FXD C FILM | 22 OHM 5% 1/4W |
| R152 | 40-27-1152 | FXD C FILM | 150 OHM 5% 1/4W |
| R153 | 40-27-1152 | FXD C FILM | 150 OHM 5% 1/4W |
| R154 | 40-27-0222 | FXD C FILM | 22 OHM 5% 1/4W |
| R155 | 42-72-2100 | FXD M FILM | 1K OHM 1% 1/4W |
| R156 | 42-72-2100 | FXD M FILM | 1K OHM 1% 1/4W |
| R157 | 40-27-1222 | FXD C FILM | 220 OHM 5% 1/4W |
| R158 | * 40-27-2102 | FXD C FILM | 1K OHM 5% 1/4W |
| R159 | 40-27-2392 | FXD C FILM | 3.9K OHM 5% 1/4W |
| R160 | 40-27-0102 | FXD C FILM | 10 OHM 5% 1/4W |
| R161 | 40-27-2152 | FXD C FILM | 1.5K OHM 5% 1/4W |
| R162 | 40-27-0472 | FXD C FILM | 47 OHM 5% 1/4W |
| R171 | 40-27-1122 | FXD C FILM | 120 OHM 5% 1/4W |
| R172 | 40-27-2152 | FXD C FILM | 1.5K OHM 5% 1/4W |
| R173 | 40-27-2152 | FXD C FILM | 1.5K OHM 5% 1/4W |

| REFERENCE DESIGNATOR | KIKUSUI PARTS NO. | DESCRIPTION |
|----------------------|-------------------|------------------------------|
| R174 | 40-27-1182 | FXD C FILM 180 OHM 5% 1/4W |
| R175 | 40-27-1182 | FXD C FILM 180 OHM 5% 1/4W |
| R176 | 40-27-1272 | FXD C FILM 270 OHM 5% 1/4W |
| R177 | 40-27-2472 | FXD C FILM 4.7K OHM 5% 1/4W |
| R178 | 40-27-2472 | FXD C FILM 4.7K OHM 5% 1/4W |
| R179 | 40-27-0472 | FXD C FILM 47 OHM 5% 1/4W |
| R180 | 40-27-0472 | FXD C FILM 47 OHM 5% 1/4W |
| R184 | 40-27-0222 | FXD C FILM 22 OHM 5% 1/4W |
| R187 | 40-27-2562 | FXD C FILM 5.6K OHM 5% 1/4W |
| R189 | 38-00-0000 | THERMISTEK 250 OHM |
| R202 | 40-27-0332 | FXD C FILM 33 OHM 5% 1/4W |
| R203 | 42-74-5100 | FXD M FILM 1M OHM 1% 1/2W |
| R204 | 42-74-4900 | FXD M FILM 900K OHM 1% 1/2W |
| R205 | 42-72-4111 | FXD M FILM 111K OHM 1% 1/4W |
| R206 | 42-74-4990 | FXD M FILM 990K OHM 1% 1/2W |
| R207 | 42-72-3101 | FXD M FILM 10.1K OHM 1% 1/4W |
| R208 | 40-27-0222 | FXD C FILM 22 OHM 5% 1/4W |
| R209 | 40-27-0682 | FXD C FILM 68 OHM 5% 1/4W |
| R210 | 40-27-0102 | FXD C FILM 10 OHM 5% 1/4W |
| R211 | 40-37-4471 | FXD C FILM 470K OHM 5% 1/2W |
| R212 | 40-27-2102 | FXD C FILM 1K OHM 5% 1/4W |
| R213 | 40-27-2562 | FXD C FILM 5.6K OHM 5% 1/4W |
| R214 | 40-27-2102 | FXD C FILM 1K OHM 5% 1/4W |
| R215 | 40-27-1102 | FXD C FILM 100 OHM 5% 1/4W |
| R216 | 40-27-1682 | FXD C FILM 680 OHM 5% 1/4W |
| R217 | 40-27-2392 | FXD C FILM 3.9K OHM 5% 1/4W |
| R218 | 40-27-2822 | FXD C FILM 8.2K OHM 5% 1/4W |
| R219 | 40-27-2562 | FXD C FILM 5.6K OHM 5% 1/4W |
| R220 | 40-27-2122 | FXD C FILM 1.2K OHM 5% 1/4W |
| R221 | 40-27-0102 | FXD C FILM 10 OHM 5% 1/4W |
| R222 | 40-27-0102 | FXD C FILM 10 OHM 5% 1/4W |
| R223 | 44-04-0000 | FXD M GLAZE R-NETWORK |
| R231 | 40-27-1102 | FXD C FILM 100 OHM 5% 1/4W |
| R232 | 40-27-1122 | FXD C FILM 120 OHM 5% 1/4W |
| R233 | 40-27-1122 | FXD C FILM 120 OHM 5% 1/4W |
| R234 | 40-27-2562 | FXD C FILM 5.6K OHM 5% 1/4W |
| R235 | 40-27-2562 | FXD C FILM 5.6K OHM 5% 1/4W |
| R236 | 40-27-1682 | FXD C FILM 680 OHM 5% 1/4W |
| R237 | 40-27-3472 | FXD C FILM 47K OHM 5% 1/4W |
| R238 | 40-27-1102 | FXD C FILM 100 OHM 5% 1/4W |
| R239 | 42-72-1470 | FXD M FILM 470 OHM 1% 1/4W |
| R240 | 40-27-1272 | FXD C FILM 270 OHM 5% 1/4W |
| R241 | 42-72-1470 | FXD M FILM 470 OHM 1% 1/4W |
| R242 | 42-72-0560 | FXD M FILM 56 OHM 1% 1/4W |
| R244 | 42-72-0560 | FXD M FILM 56 OHM 1% 1/4W |
| R245 | 40-27-3472 | FXD C FILM 47K OHM 5% 1/4W |
| R246 | 40-27-0272 | FXD C FILM 27 OHM 5% 1/4W |
| R247 | 40-27-0272 | FXD C FILM 27 OHM 5% 1/4W |
| R248 | 42-72-1680 | FXD M FILM 680 OHM 1% 1/4W |
| R249 | 42-72-1680 | FXD M FILM 680 OHM 1% 1/4W |
| R250 | 40-27-0222 | FXD C FILM 22 OHM 5% 1/4W |
| R251 | 40-27-0222 | FXD C FILM 22 OHM 5% 1/4W |
| R252 | 40-27-1152 | FXD C FILM 150 OHM 5% 1/4W |
| R253 | 40-27-1152 | FXD C FILM 150 OHM 5% 1/4W |
| R254 | 40-27-0822 | FXD C FILM 82 OHM 5% 1/4W |
| R255 | 42-72-2100 | FXD M FILM 1K OHM 1% 1/4W |
| R256 | 42-72-2100 | FXD M FILM 1K OHM 1% 1/4W |
| R257 | 40-27-1222 | FXD C FILM 220 OHM 5% 1/4W |
| R258 | 40-27-1222 | FXD C FILM 220 OHM 5% 1/4W |
| R271 | 40-27-1122 | FXD C FILM 120 OHM 5% 1/4W |
| R272 | 40-27-2152 | FXD C FILM 1.5K OHM 5% 1/4W |
| R273 | 40-27-2152 | FXD C FILM 1.5K OHM 5% 1/4W |
| R274 | 40-27-1182 | FXD C FILM 180 OHM 5% 1/4W |
| R275 | 40-27-1182 | FXD C FILM 180 OHM 5% 1/4W |
| R276 | 40-27-1272 | FXD C FILM 270 OHM 5% 1/4W |
| R277 | 40-27-2472 | FXD C FILM 4.7K OHM 5% 1/4W |
| R278 | 40-27-2472 | FXD C FILM 4.7K OHM 5% 1/4W |
| R279 | 40-27-0472 | FXD C FILM 47 OHM 5% 1/4W |
| R282 | 40-27-0472 | FXD C FILM 47 OHM 5% 1/4W |
| R283 | 40-27-2122 | FXD C FILM 1.2K OHM 5% 1/4W |
| R284 | 40-27-2682 | FXD C FILM 6.8K OHM 5% 1/4W |
| R285 | 40-27-1222 | FXD C FILM 220 OHM 5% 1/4W |
| R286 | 40-27-0222 | FXD C FILM 22 OHM 5% 1/4W |
| R287 | 40-27-2222 | FXD C FILM 2.2K OHM 5% 1/4W |
| R301 | 40-27-0102 | FXD C FILM 10 OHM 5% 1/4W |
| R302 | 40-27-0102 | FXD C FILM 10 OHM 5% 1/4W |
| R303 | 42-72-1470 | FXD M FILM 470 OHM 1% 1/4W |

KIKUSUI S8109001

For Service Manuals Contact
MAURITRON TECHNICAL SERVICES
 8 Cherry Tree Rd, Chinnor
 Oxon OX9 4QY
 Tel: 01844-351894 Fax: 01844-352554
 Email: enquiries@mauritron.co.uk

| REFERENCE DESIGNATOR | KIKUSUI PARTS NO. | DESCRIPTION | |
|----------------------|-------------------|-------------------------------|------------------|
| R304 | 42-72-1470 | FXD M FILM | 470 OHM 1% 1/4W |
| R305 | 40-27-1822 | FXD C FILM | 820 OHM 5% 1/4W |
| R306 | 40-27-1822 | FXD C FILM | 820 OHM 5% 1/4W |
| R307 | 40-27-1822 | FXD C FILM | 820 OHM 5% 1/4W |
| R308 | 40-27-0822 | FXD C FILM | 82 OHM 5% 1/4W |
| R309 | 40-27-0822 | FXD C FILM | 82 OHM 5% 1/4W |
| R310 | 40-27-1222 | FXD C FILM | 220 OHM 5% 1/4W |
| R311 | 40-27-1222 | FXD C FILM | 220 OHM 5% 1/4W |
| R312 | 40-27-2102 | FXD C FILM | 1K OHM 5% 1/4W |
| R313 | 40-27-2562 | FXD C FILM | 5.6K OHM 5% 1/4W |
| R314 | 40-27-2102 | FXD C FILM | 1K OHM 5% 1/4W |
| R315 | 40-27-2102 | FXD C FILM | 1K OHM 5% 1/4W |
| R316 | 40-27-3102 | FXD C FILM | 10K OHM 5% 1/4W |
| R318 | 40-27-3102 | FXD C FILM | 10K OHM 5% 1/4W |
| R319 | 40-27-2102 | FXD C FILM | 1K OHM 5% 1/4W |
| R320 | 44-07-0020 | FXD M GLAZE RESISTOR NETWORKS | 10K OHM X4 |
| R322 | 40-27-2102 | FXD C FILM | 1K OHM 5% 1/4W |
| R331 | 42-72-0910 | FXD M FILM | 91 OHM 1% 1/4W |
| R332 | 42-72-0910 | FXD M FILM | 91 OHM 1% 1/4W |
| R333 | 42-72-1470 | FXD M FILM | 470 OHM 1% 1/4W |
| R334 | 42-72-1470 | FXD M FILM | 470 OHM 1% 1/4W |
| R335 | 40-27-2102 | FXD C FILM | 1K OHM 5% 1/4W |
| R336 | 40-27-1682 | FXD C FILM | 680 OHM 5% 1/4W |
| R337 | 40-27-1682 | FXD C FILM | 680 OHM 5% 1/4W |
| R338 | 40-27-1472 | FXD C FILM | 470 OHM 5% 1/4W |
| R339 | 40-27-1472 | FXD C FILM | 470 OHM 5% 1/4W |
| R340 | 40-27-2152 | FXD C FILM | 1.5K OHM 5% 1/4W |
| R341 | * 40-27-3272 | FXD C FILM | 27K OHM 5% 1/4W |
| R342 | 40-27-1222 | FXD C FILM | 220 OHM 5% 1/4W |
| R343 | 40-27-1222 | FXD C FILM | 220 OHM 5% 1/4W |
| R344 | 40-27-0222 | FXD C FILM | 22 OHM 5% 1/4W |
| R345 | 40-27-0222 | FXD C FILM | 22 OHM 5% 1/4W |
| R346 | 44-91-3330 | FXD M OXIDE | 33K OHM 5% 1W |
| R347 | 44-91-3330 | FXD M OXIDE | 33K OHM 5% 1W |
| R348 | 40-27-0102 | FXD C FILM | 10 OHM 5% 1/4W |
| R349 | 40-27-8472 | FXD C FILM | 4.7 OHM 5% 1/4W |
| R350 | 40-27-8472 | FXD C FILM | 4.7 OHM 5% 1/4W |
| R351 | 40-27-2332 | FXD C FILM | 3.3K OHM 5% 1/4W |
| R352 | 40-37-3471 | FXD C FILM | 47K OHM 5% 1/2W |
| R353 | 40-37-3471 | FXD C FILM | 47K OHM 5% 1/2W |
| R354 | 40-27-2332 | FXD C FILM | 3.3K OHM 5% 1/4W |
| R355 | 40-27-8472 | FXD C FILM | 4.7 OHM 5% 1/4W |
| R356 | 40-27-8472 | FXD C FILM | 4.7 OHM 5% 1/4W |
| R357 | 40-27-2102 | FXD C FILM | 1K OHM 5% 1/4W |
| R358 | 40-27-0822 | FXD C FILM | 82 OHM 5% 1/4W |
| R359 | 40-27-2102 | FXD C FILM | 1K OHM 5% 1/4W |
| R360 | 40-27-0102 | FXD C FILM | 10 OHM 5% 1/4W |
| R361 | 40-27-0102 | FXD C FILM | 10 OHM 5% 1/4W |
| R362 | 40-27-1472 | FXD C FILM | 470 OHM 5% 1/4W |
| R363 | 40-27-1472 | FXD C FILM | 470 OHM 5% 1/4W |
| R364 | 40-27-0102 | FXD C FILM | 10 OHM 5% 1/4W |
| R365 | 40-27-0102 | FXD C FILM | 10 OHM 5% 1/4W |
| R366 | 40-27-0102 | FXD C FILM | 10 OHM 5% 1/4W |
| R367 | 40-27-0102 | FXD C FILM | 10 OHM 5% 1/4W |
| R368 | * 40-27-3102 | FXD C FILM | 10K OHM 5% 1/4W |
| R369 | 40-27-1272 | FXD C FILM | 270 OHM 5% 1/4W |
| R370 | 40-27-8472 | FXD C FILM | 4.7 OHM 5% 1/4W |
| R371 | 40-27-8472 | FXD C FILM | 4.7 OHM 5% 1/4W |
| R621 | 40-37-5221 | FXD C FILM | 2.2M OHM 5% 1/2W |
| R622 | 40-37-5221 | FXD C FILM | 2.2M OHM 5% 1/2W |
| R623 | 44-92-2120 | FXD M OXIDE | 1.2K OHM 5% 2W |
| R624 | 40-27-0102 | FXD C FILM | 10 OHM 5% 1/4W |
| R625 | 40-27-1102 | FXD C FILM | 100 OHM 5% 1/4W |
| R626 | 40-27-1222 | FXD C FILM | 220 OHM 5% 1/4W |
| R627 | 40-27-1562 | FXD C FILM | 560 OHM 5% 1/4W |
| R628 | 42-72-4120 | FXD M FILM | 120K OHM 1% 1/4W |
| R629 | 42-72-2910 | FXD M FILM | 9.1K OHM 1% 1/4W |
| R631 | 44-91-0010 | FXD M OXIDE | 1 OHM 5% 1W |
| R632 | 40-27-1102 | FXD C FILM | 100 OHM 5% 1/4W |
| R633 | 44-91-1100 | FXD M OXIDE | 100 OHM 5% 1W |
| R634 | 40-27-1102 | FXD C FILM | 100 OHM 5% 1/4W |
| R635 | 40-37-8222 | FXD C FILM | 2.2 OHM 5% 1/2W |
| R636 | 44-91-1100 | FXD M OXIDE | 100 OHM 5% 1W |
| R637 | 40-27-2562 | FXD C FILM | 5.6K OHM 5% 1/4W |
| R638 | 42-72-3120 | FXD M FILM | 12K OHM 1% 1/4W |
| R639 | 42-72-3120 | FXD M FILM | 12K OHM 1% 1/4W |
| R640 | 40-27-2562 | FXD C FILM | 5.6K OHM 5% 1/4W |

| REFERENCE DESIGNATOR | KIKUSUI PARTS NO. | DESCRIPTION |
|----------------------|-------------------|-----------------------------------|
| R641 | 40-27-2562 | FXD C FILM 5.6K OHM 5% 1/4W |
| R642 | 42-72-2390 | FXD M FILM 3.9K OHM 1% 1/4W |
| R643 | 42-72-2910 | FXD M FILM 9.1K OHM 1% 1/4W |
| R644 | * 40-27-1152 | FXD C FILM 150 OHM 5% 1/4W |
| R646 | 40-37-1101 | FXD C FILM 100 OHM 5% 1/2W |
| RV101 | 48-33-3200 | VAR M FILM 20K OHM |
| RV102 | 48-33-1100 | VAR M FILM 100 OHM |
| RV103 | 48-33-1500 | VAR M FILM 500 OHM |
| RV105 | 48-33-3200 | VAR M FILM 20K OHM |
| RV106 | 48-33-1100 | VAR M FILM 100 OHM |
| RV107 | 48-33-2100 | VAR M FILM 1K OHM |
| RV108 | 48-33-2200 | VAR M FILM 2K OHM |
| RV109 | 48-33-1500 | VAR M FILM 500 OHM |
| RV110 | 48-33-2100 | VAR M FILM 1K OHM |
| RV112 | 48-33-3200 | VAR M FILM 20K OHM |
| RV201 | 48-33-3200 | VAR M FILM 20K OHM |
| RV202 | 48-33-1100 | VAR M FILM 100 OHM |
| RV203 | 48-33-1500 | VAR M FILM 500 OHM |
| RV205 | 48-33-3200 | VAR M FILM 20K OHM |
| RV207 | 48-33-2100 | VAR M FILM 1K OHM |
| RV209 | 48-33-1500 | VAR M FILM 500 OHM |
| RV210 | 48-33-2100 | VAR M FILM 1K OHM |
| RV212 | 48-33-3200 | VAR M FILM 20K OHM |
| RV301 | 48-33-1500 | VAR M FILM 500 OHM |
| RV302 | 48-33-2200 | VAR M FILM 2K OHM |
| RV606 | 48-33-2100 | VAR M FILM 1K OHM |
| C101 | 50-94-3590 | FXD PLSTC FILM 0.022UF 20% 630V |
| C102 | 57-10-1191 | VAR CER 3-10PF |
| C103 | 57-10-1181 | VAR CER 3-6PF |
| C104 | 52-06-3165 | FXD CER 33PF 10% 500V TYPE1 |
| C105 | 57-10-1191 | VAR CER 3-10PF |
| C106 | 57-10-1181 | VAR CER 3-6PF |
| C107 | 52-06-2265 | FXD CER 220PF 10% 50V TYPE1 |
| C108 | 52-06-2265 | FXD CER 220PF 10% 50V TYPE1 |
| C111 | 50-87-0510 | FXD PLSTC FILM 2200PF 10% 400V |
| C112 | 52-05-2468 | FXD CER 0.01UF +80-20% 50V TYPE2 |
| C113 | 52-01-3345 | FXD CER 1000PF 10% 500V TYPE2 |
| C114 | 52-01-3345 | FXD CER 1000PF 10% 500V TYPE2 |
| C115 | 52-05-2468 | FXD CER 0.01UF +80-20% 50V TYPE2 |
| C116 | 54-00-0311 | FXD ELECT 10UF 50V |
| C117 | 52-06-3125 | FXD CER 15PF 10% 500V TYPE1 |
| C118 | 52-06-3051 | FXD CER 5PF 10% 500V TYPE1 |
| C119 | 52-06-2225 | FXD CER 100PF 10% 50V TYPE1 |
| C121 | 52-06-2265 | FXD CER 220PF 10% 50V TYPE1 |
| C122 | 52-06-2265 | FXD CER 220PF 10% 50V TYPE1 |
| C131 | 57-10-1203 | VAR CER 5-20PF |
| C132 | 52-06-3051 | FXD CER 5PF 10% 500V TYPE1 |
| C133 | 52-06-3051 | FXD CER 5PF 10% 500V TYPE1 |
| C151 | - | - |
| C152 | 52-05-2468 | FXD CER 0.01UF +80-20% 50V TYPE2 |
| C153 | 54-00-0311 | FXD ELECT 10UF 50V |
| C171 | 57-10-1223 | VAR CER 8-50PF |
| C172 | 52-05-2468 | FXD CER 0.01UF +80-20% 50V TYPE2 |
| C173 | 52-05-2468 | FXD CER 0.01UF +80-20% 50V TYPE2 |
| C174 | 52-06-2225 | FXD CER 100PF 10% 50V TYPE1 |
| C175 | 52-06-2225 | FXD CER 100PF 10% 50V TYPE1 |
| C177 | 52-06-2215 | FXD CER 82PF 10% 500V TYPE1 |
| C178 | 52-06-2215 | FXD CER 82PF 10% 500V TYPE1 |
| C179 | 52-05-2468 | FXD CER 0.01UF +80-20% 50V TYPE2 |
| C200 | 52-03-3469 | FXD CER 0.01UF +100-0% 500V TYPE2 |
| C201 | 50-94-3590 | FXD PLSTC FILM 0.022UF 20% 630V |
| C202 | 57-10-1191 | VAR CER 3-10PF |
| C203 | 57-10-1181 | VAR CER 3-6PF |
| C204 | 52-06-3165 | FXD CER 33PF 10% 500V TYPE1 |
| C205 | 57-10-1191 | VAR CER 3-10PF |
| C206 | 57-10-1181 | VAR CER 3-6PF |
| C207 | 52-06-2265 | FXD CER 220PF 10% 50V TYPE1 |
| C208 | 52-06-2265 | FXD CER 220PF 10% 50V TYPE1 |
| C211 | 50-87-0510 | FXD PLSTC FILM 2200PF 10% 400V |
| C212 | 52-05-2468 | FXD CER 0.01UF +80-20% 50V TYPE2 |
| C213 | 52-01-3345 | FXD CER 1000PF 10% 500V TYPE2 |
| C214 | 52-01-3345 | FXD CER 1000PF 10% 500V TYPE2 |
| C215 | 52-05-2468 | FXD CER 0.01UF +80-20% 50V TYPE2 |
| C216 | 54-00-0311 | FXD ELECT 10UF 50V |
| C218 | 52-06-3051 | FXD CER 5PF 10% 500V TYPE1 |

For Service Manuals Contact
MAURITRON TECHNICAL SERVICES
8 Cherry Tree Rd, Chinnor
Oxon OX9 4QY
Tel: 01844-351694 Fax: 01844-352554
Email: enquiries@mauritron.co.uk

| REFERENCE DESIGNATOR | KIKUSUI PARTS NO. | DESCRIPTION | |
|----------------------|-------------------|----------------------------------|----------------|
| C219 | 52-06-2225 | FXD CER 100PF 10% 50V TYPE1 | |
| C221 | 52-06-2265 | FXD CER 220PF 10% 50V TYPE1 | |
| C222 | 52-06-2265 | FXD CER 220PF 10% 50V TYPE1 | |
| C231 | 57-10-1203 | VAR CER 5-20PF | |
| C232 | 52-06-3051 | FXD CER 5PF 10% 500V TYPE1 | |
| C233 | 52-06-3051 | FXD CER 5PF 10% 500V TYPE1 | |
| C251 | - | - | |
| C252 | 52-05-2468 | FXD CER 0.01UF +80-20% 50V TYPE2 | |
| C271 | 57-10-1223 | VAR CER 8-50PF | |
| C272 | 52-05-2468 | FXD CER 0.01UF +80-20% 50V TYPE2 | |
| C273 | 52-05-2468 | FXD CER 0.01UF +80-20% 50V TYPE2 | |
| C274 | 52-06-2225 | FXD CER 100PF 10% 50V TYPE1 | |
| C275 | 52-06-2225 | FXD CER 100PF 10% 50V TYPE1 | |
| C277 | 52-06-2215 | FXD CER 82PF 10% 500V TYPE1 | |
| C278 | 52-06-2215 | FXD CER 82PF 10% 500V TYPE1 | |
| C279 | 52-05-2468 | FXD CER 0.01UF +80-20% 50V TYPE2 | |
| C282 | 52-05-2468 | FXD CER 0.01UF +80-20% 50V TYPE2 | |
| C301 | 54-00-0121 | FXD ELECT 100UF 25V | |
| C302 | 54-00-0121 | FXD ELECT 100UF 25V | |
| C303 | 52-01-3345 | FXD CER 1000PF 10% 500V TYPE2 | |
| C306 | 52-05-2468 | FXD CER 0.01UF +80-20% 50V TYPE2 | |
| C310 | 52-01-3365 | FXD CER 1500PF 10% 50V TYPE2 | |
| C331 | 57-10-1203 | VAR CER 5-20PF | |
| C332 | 52-06-3051 | FXD CER 5PF 10% 500V TYPE1 | |
| C333 | 50-45-0500 | FXD PLSTC FILM 0.01MF 5% 50V | |
| C334 | 50-45-0500 | FXD PLSTC FILM 0.01MF 5% 50V | |
| C335 | 52-96-1140 | FXD COMP 0.47PF 10% 500V | |
| C336 | 52-96-1140 | FXD COMP 0.47PF 10% 500V | |
| C337 | 50-77-3500 | FXB PLSTC FILM 0.047UF 20% 250V | |
| C338 | 50-77-3500 | FXD PLSTC FILM 0.047UF 20% 250V | |
| C339 | 50-96-3590 | FXD PLSTC FILM 0.022UF 20% 630V | |
| C340 | - | - | |
| C341 | 50-96-3590 | FXD PLSTC FILM 0.022UF 20% 630V | |
| C342 | 54-60-1550 | FXD ELECT 1UF 160V | |
| C343 | 52-05-1498 | FXD CER 0.1UF +80-20% 25V TYPE2 | |
| C344 | 50-67-0050 | FXD PLSTC FILM 0.047UF 10% 100V | |
| C345 | * 52-06-3155 | FXD CER 27PF 10% 500V TYPE1 | |
| C346 | * 52-06-3155 | FXD CER 27PF 10% 500V TYPE1 | |
| C347 | 54-00-0311 | FXD ELECT 10UF 50V | |
| C348 | 54-00-0311 | FXD ELECT 10UF 50V | |
| C349 | 52-06-3102 | FXD CER 10PF 10% 500V TYPE1 | |
| C351 | 52-05-2468 | FXD CER 0.01UF +80-20% 50V TYPE2 | |
| C352 | 52-05-2468 | FXD CER 0.01UF +80-20% 50V TYPE2 | |
| C621 | 50-67-0040 | FXD PLSTC FILM 0.022UF 10% 100V | |
| C622 | 50-67-0040 | FXD PLSTC FILM 0.022UF 10% 100V | |
| C623 | 54-60-1620 | FXD ELECT 47UF 200V | |
| C624 | 54-70-1020 | FXD ELECT 2.2UF 250V | |
| C625 | 54-60-1550 | FXD ELECT 1UF 160V | |
| C626 | 54-00-0231 | FXD ELECT 1000UF 35V | |
| C627 | 54-00-0231 | FXD ELECT 1000UF 35V | |
| C628 | 54-00-0114 | FXD ELECT 47UF 25V | |
| L301 | 67-10-0880 | INDUCTOR 2.2UH 20% | |
| L302 | 67-10-0880 | INDUCTOR 2.2UH 20% | |
| S101 | 80-98-0580 | SW ROTARY WITH RV VOLT/DIV | ALPS S21P2YC |
| S102 | 82-70-8231 | LEVER SWITCH | ALPS SLR823-1 |
| S201 | 80-98-0580 | SW ROTARY WITH RV VOLT/DIV | ALPS S21P2YC |
| S202 | 82-70-8231 | LEVER SWITCH | ALPS SLR823-1 |
| S301 | 82-70-8243 | LEVER SWITCH | ALPS SLR824-3 |
| A2 ASSEMBLY | | | |
| CR401 | 32-11-5880 | DIODE VR=30V IO=120MA | TOSHIBA 1S1588 |
| CR402 | 32-11-5880 | DIODE VR=30V IO=120MA | TOSHIBA 1S1588 |
| CR403 | 32-30-0860 | DIODE VR=30V IO=30MA | HITACHI 1S884 |
| CR404 | 32-11-5880 | DIODE VR=30V IO=120MA | TOSHIBA 1S1588 |
| CR452 | 32-11-5880 | DIODE VR=30V IO=120MA | TOSHIBA 1S1588 |
| CR453 | 32-11-5880 | DIODE VR=30V IO=120MA | TOSHIBA 1S1588 |
| CR454 | 32-92-0033 | ZENER VZ=3.2-3.4V | HITACHI HZ3C-2 |
| CR455 | 32-11-5880 | DIODE VR=30V IO=120MA | TOSHIBA 1S1588 |
| CR456 | 32-11-5880 | DIODE VR=30V IO=120MA | TOSHIBA 1S1588 |
| CR457 | 32-11-5880 | DIODE VR=30V IO=120MA | TOSHIBA 1S1588 |
| CR458 | 32-11-5880 | DIODE VR=30V IO=120MA | TOSHIBA 1S1588 |
| CR459 | 32-11-5880 | DIODE VR=30V IO=120MA | TOSHIBA 1S1588 |
| CR460 | 32-11-5880 | DIODE VR=30V IO=120MA | TOSHIBA 1S1588 |
| CR461 | 32-11-5880 | DIODE VR=30V IO=120MA | TOSHIBA 1S1588 |
| CR462 | 32-11-5880 | DIODE VR=30V IO=120MA | TOSHIBA 1S1588 |

| REFERENCE DESIGNATOR | KIKUSUI PARTS NO. | DESCRIPTION | |
|----------------------|-------------------|----------------------------|---------------------|
| CR463 | 32-30-0860 | DIODE VR=30V IO=30MA | HITACHI 1SS86 |
| CR464 | 32-11-5880 | DIODE VR=30V IO=120MA | TOSHIBA 1S1588 |
| CR465 | 32-92-0056 | ZENER VZ=5.5-5.8V P=0.4W | NEC RDS.6J |
| CR468 | 32-11-5880 | DIODE VR=30V IO=120MA | TOSHIBA 1S1588 |
| CR469 | 32-11-5880 | DIODE VR=30V IO=120MA | TOSHIBA 1S1588 |
| CR501 | 32-30-0860 | DIODE VR=30V IO=30MA | HITACHI 1SS86 |
| CR502 | 32-11-5880 | DIODE VR=30V IO=120MA | TOSHIBA 1S1588 |
| CR503 | 32-30-0830 | DIODE VR=250V IO=200MA | HITACHI 1SS83 |
| CR504 | 32-11-5880 | DIODE VR=30V IO=120MA | TOSHIBA 1S1588 |
| CR651 | 32-92-0056 | ZENER VZ=5.5-5.8V P=0.4W | NEC RDS.6J |
| CR652 | 32-11-5880 | DIODE VR=30V IO=120MA | TOSHIBA 1S1588 |
| CR653 | 32-11-5880 | DIODE VR=30V IO=120MA | TOSHIBA 1S1588 |
| CR654 | 32-11-5880 | DIODE VR=30V IO=120MA | TOSHIBA 1S1588 |
| CR655 | 32-90-1951 | DIODE VR=6KV FAST RECOVERY | SANKEN GHV-06SSN |
| CR656 | 32-90-1951 | DIODE VR=6KV FAST RECOVERY | SANKEN GHV-06SSN |
| CR657 | 32-30-0830 | DIODE VR=250V IO=200MA | HITACHI 1SS83 |
| CR658 | 32-90-1820 | DIODE VR=2KV FAST RECOVERY | HITACHI ERB26-20 |
| CR659 | 32-30-0830 | DIODE VR=250V IO=200MA | HITACHI 1SS83 |
| CR660 | 32-30-0830 | DIODE VR=250V IO=200MA | HITACHI 1SS83 |
| CR661 | 32-30-0830 | DIODE VR=250V IO=200MA | HITACHI 1SS83 |
| CR662 | 32-30-0830 | DIODE VR=250V IO=200MA | HITACHI 1SS83 |
| CR663 | 32-30-0830 | DIODE VR=250V IO=200MA | HITACHI 1SS83 |
| CR664 | 32-30-0830 | DIODE VR=250V IO=200MA | HITACHI 1SS83 |
| CR665 | 32-11-5880 | DIODE VR=30V IO=120MA | TOSHIBA 1S1588 |
| CR666 | 32-92-0022 | ZENER VZ=2.1-2.3V | HITACHI HZ2B-3 |
| CR667 | 32-92-0022 | ZENER VZ=2.1-2.3V | HITACHI HZ2B-3 |
| CR668 | 32-11-5880 | DIODE VR=30V IO=120MA | TOSHIBA 1S1588 |
| CR669 | 32-11-5880 | DIODE VR=30V IO=120MA | TOSHIBA 1S1588 |
| CR701 | 32-11-5880 | DIODE VR=30V IO=120MA | TOSHIBA 1S1588 |
| CR702 | 32-11-5880 | DIODE VR=30V IO=120MA | TOSHIBA 1S1588 |
| CR703 | 32-11-5880 | DIODE VR=30V IO=120MA | TOSHIBA 1S1588 |
| CR704 | 32-30-0860 | DIODE VR=30V IO=30MA | HITACHI 1SS86 |
| CR705 | 32-11-5880 | DIODE VR=30V IO=120MA | TOSHIBA 1S1588 |
| CR706 | 32-11-5880 | DIODE VR=30V IO=120MA | TOSHIBA 1S1588 |
| CR707 | 32-11-5880 | DIODE VR=30V IO=120MA | TOSHIBA 1S1588 |
| CR708 | 32-11-5880 | DIODE VR=30V IO=120MA | TOSHIBA 1S1588 |
| CR709 | 32-11-5880 | DIODE VR=30V IO=120MA | TOSHIBA 1S1588 |
| Q401 | 30-10-8381 | TR SI PNP | MATSUSHITA 2SA838-B |
| Q402 | 30-10-8381 | TR SI PNP | MATSUSHITA 2SA838-B |
| Q403 | 31-20-1073 | FET | SONY 2SK107-3 |
| Q404 | 30-31-9071 | TR SI NPN | HITACHI 2SC1907 |
| Q405 | 30-31-9071 | TR SI NPN | HITACHI 2SC1907 |
| Q406 | 30-10-8441 | TR SI PNP | HITACHI 2SA844-D |
| Q407 | 30-10-8441 | TR SI PNP | HITACHI 2SA844-D |
| Q408 | 30-10-8441 | TR SI PNP | HITACHI 2SA844-D |
| Q409 | 30-10-8441 | TR SI PNP | HITACHI 2SA844-D |
| Q410 | 31-20-1171 | FET | TOSHIBA 2SK117-BL |
| Q411 | 30-11-0151 | TR SI PNP | TOSHIBA 2SA1015-Y |
| Q412 | 30-10-8381 | TR SI PNP | MATSUSHITA 2SA838-B |
| Q413 | 30-31-9071 | TR SI NPN | HITACHI 2SC1907 |
| Q415 | 30-31-9071 | TR SI NPN | HITACHI 2SC1907 |
| Q416 | 30-10-8441 | TR SI PNP | HITACHI 2SA844-D |
| Q417 | 30-31-9071 | TR SI NPN | HITACHI 2SC1907 |
| Q418 | 30-30-9451 | TR SI NPN | NEC 2SC945-Q |
| Q419 | 30-10-8441 | TR SI PNP | HITACHI 2SA844-D |
| Q420 | 30-10-8441 | TR SI PNP | HITACHI 2SA844-D |
| Q421 | 30-30-9451 | TR SI NPN | NEC 2SC945-Q |
| Q422 | 30-30-9451 | TR SI NPN | NEC 2SC945-Q |
| Q423 | 30-10-8441 | TR SI PNP | HITACHI 2SA844-D |
| Q424 | 30-31-8431 | TR SI NPN | NEC 2SC1843-E |
| Q425 | 31-20-1171 | FET | TOSHIBA 2SK117-BL |
| Q426 | 31-20-1171 | FET | TOSHIBA 2SK117-BL |
| Q427 | 30-10-8441 | TR SI PNP | HITACHI 2SA844-D |
| Q428 | 30-30-9451 | TR SI NPN | NEC 2SC945-Q |
| Q429 | 30-10-8441 | TR SI PNP | HITACHI 2SA844-D |
| Q430 | 30-10-8441 | TR SI PNP | HITACHI 2SA844-D |
| Q431 | 30-30-9451 | TR SI NPN | NEC 2SC945-Q |
| Q501 | 30-11-0151 | TR SI PNP | TOSHIBA 2SA1015-Y |
| Q502 | 30-11-0151 | TR SI PNP | TOSHIBA 2SA1015-Y |
| Q503 | 30-30-9451 | TR SI NPN | NEC 2SC945-Q |
| Q504 | 30-30-9451 | TR SI NPN | NEC 2SC945-Q |
| Q505 | 30-31-9071 | TR SI NPN | HITACHI 2SC1907 |
| Q506 | 30-31-9071 | TR SI NPN | HITACHI 2SC1907 |
| Q507 | 30-31-9071 | TR SI NPN | HITACHI 2SC1907 |
| Q508 | 30-10-8381 | TR SI PNP | MATSUSHITA 2SA838-B |
| Q509 | 30-20-6481 | TR SI PNP | HITACHI 2SB648A |

For Service Manuals Contact
MAURITRON TECHNICAL SERVICES
8 Cherry Tree Rd, Chinnor
Oxon OX9 4QY
Tel: 01844-351694 Fax: 01844-352554
Email: enquiries@mauritron.co.uk

| REFERENCE DESIGNATOR | KIKUSUI PARTS NO. | DESCRIPTION | |
|----------------------|-------------------|------------------------------|-------------------|
| Q510 | 30-40-6681 | TR SI NFN | HITACHI 2SD668A-C |
| Q511 | 30-40-6681 | TR SI NFN | HITACHI 2SD668A-C |
| Q512 | 30-20-6481 | TR SI PNF | HITACHI 2SB648A |
| Q651 | 30-40-8802 | TR SI NFN | NEC 2SD880-Y |
| Q652 | 30-10-8441 | TR SI PNF | HITACHI 2SA844-D |
| Q654 | 30-31-9071 | TR SI NFN | HITACHI 2SC1907 |
| Q655 | 30-31-9071 | TR SI NFN | HITACHI 2SC1907 |
| Q656 | 30-32-3710 | TR SI NFN | NEC 2SC2371-L |
| Q657 | 30-32-3710 | TR SI NFN | NEC 2SC2371-L |
| Q658 | 30-32-3710 | TR SI NFN | NEC 2SC2371-L |
| Q659 | 30-32-3710 | TR SI NFN | NEC 2SC2371-L |
| Q660 | 31-20-1171 | FET | TOSHIBA 2SK117-BL |
| Q702 | 30-10-8441 | TR SI PNF | HITACHI 2SA844-D |
| Q703 | 30-10-8441 | TR SI PNF | HITACHI 2SA844-D |
| Q704 | 30-10-8441 | TR SI PNF | HITACHI 2SA844-D |
| Q705 | 30-10-8441 | TR SI PNF | HITACHI 2SA844-D |
| Q706 | 30-10-8441 | TR SI PNF | HITACHI 2SA844-D |
| Q707 | 30-30-9451 | TR SI NFN | NEC 2SC945-Q |
| Q708 | 30-10-8441 | TR SI PNF | HITACHI 2SA844-D |
| Q709 | 30-10-8441 | TR SI PNF | HITACHI 2SA844-D |
| Q710 | 31-20-1171 | FET | TOSHIBA 2SK117-BL |
| Q711 | 30-31-8431 | TR SI NFN | NEC 2SC1843-E |
| Q712 | 30-10-8441 | TR SI PNF | HITACHI 2SA844-D |
| Q713 | 30-10-8441 | TR SI PNF | HITACHI 2SA844-D |
| U401 | 35-70-0001 | QUAD 2-INPUT POSI-NAND | T.I SN74LS00N |
| U402 | 35-70-1121 | DUAL J-K F-F | T.I SN74LS112N |
| U403 | 34-00-0215 | J-FET INPUT OPEAMP | N.S LF13741N |
| U404 | 34-69-0030 | TRIPLE 2-CHANNEL MULTIPLEXER | TOSHIBA TC4053BP |
| U651 | 34-00-0215 | J-FET INPUT OPEAMP | N.S LF13741N |
| U701 | 35-70-1121 | DUAL J-K F-F | T.I SN74LS112N |
| U702 | 35-70-0001 | QUAD 2-INPUT POSI-NAND | T.I SN74LS00N |
| U703 | 34-00-0215 | J-FET INPUT OPEAMP | N.S LF13741N |
| R401 | 40-27-0472 | FXD C FILM 47 OHM 5% 1/4W | |
| R402 | 42-72-2100 | FXD M FILM 1K OHM 1% 1/4W | |
| R403 | 40-27-2222 | FXD C FILM 2.2K OHM 5% 1/4W | |
| R404 | 40-27-2122 | FXD C FILM 1.2K OHM 5% 1/4W | |
| R405 | 40-27-2222 | FXD C FILM 2.2K OHM 5% 1/4W | |
| R406 | 40-27-2332 | FXD C FILM 3.3K OHM 5% 1/4W | |
| R407 | 40-27-0472 | FXD C FILM 47 OHM 5% 1/4W | |
| R408 | 40-27-3472 | FXD C FILM 47K OHM 5% 1/4W | |
| R409 | 42-74-5100 | FXD M FILM 1M OHM 1% 1/2W | |
| R410 | 40-27-3102 | FXD C FILM 10K OHM 5% 1/4W | |
| R411 | 40-27-2152 | FXD C FILM 1.5K OHM 5% 1/4W | |
| R412 | 40-27-1562 | FXD C FILM 560 OHM 5% 1/4W | |
| R413 | 40-27-1562 | FXD C FILM 560 OHM 5% 1/4W | |
| R414 | 40-27-0682 | FXD C FILM 68 OHM 5% 1/4W | |
| R415 | 40-27-2392 | FXD C FILM 3.9K OHM 5% 1/4W | |
| R416 | 40-27-2392 | FXD C FILM 3.9K OHM 5% 1/4W | |
| R417 | 40-27-1682 | FXD C FILM 680 OHM 5% 1/4W | |
| R418 | 40-27-1682 | FXD C FILM 680 OHM 5% 1/4W | |
| R419 | 40-27-1682 | FXD C FILM 680 OHM 5% 1/4W | |
| R420 | 40-27-1682 | FXD C FILM 680 OHM 5% 1/4W | |
| R421 | 40-27-4102 | FXD C FILM 100K OHM 5% 1/4W | |
| R422 | 40-27-4102 | FXD C FILM 100K OHM 5% 1/4W | |
| R423 | 40-27-2222 | FXD C FILM 2.2K OHM 5% 1/4W | |
| R424 | 40-27-3222 | FXD C FILM 22K OHM 5% 1/4W | |
| R425 | 40-27-3102 | FXD C FILM 10K OHM 5% 1/4W | |
| R427 | 40-27-3102 | FXD C FILM 10K OHM 5% 1/4W | |
| R428 | 40-27-0332 | FXD C FILM 33 OHM 5% 1/4W | |
| R429 | 40-27-1562 | FXD C FILM 560 OHM 5% 1/4W | |
| R431 | 40-27-3102 | FXD C FILM 10K OHM 5% 1/4W | |
| R432 | 40-27-2102 | FXD C FILM 1K OHM 5% 1/4W | |
| R433 | 40-27-4472 | FXD C FILM 470K OHM 5% 1/4W | |
| R434 | 40-27-4472 | FXD C FILM 470K OHM 5% 1/4W | |
| R435 | 40-27-1392 | FXD C FILM 390 OHM 5% 1/4W | |
| R436 | 40-27-1102 | FXD C FILM 100 OHM 5% 1/4W | |
| R437 | 40-27-1272 | FXD C FILM 270 OHM 5% 1/4W | |
| R438 | 40-27-1102 | FXD C FILM 100 OHM 5% 1/4W | |
| R440 | 40-27-2102 | FXD C FILM 1K OHM 5% 1/4W | |
| R441 | 40-27-2222 | FXD C FILM 2.2K OHM 5% 1/4W | |
| R442 | 40-27-8472 | FXD C FILM 4.7 OHM 5% 1/4W | |
| R443 | 40-27-3472 | FXD C FILM 47K OHM 5% 1/4W | |
| R451 | ... | ... | |
| R452 | 40-27-1332 | FXD C FILM 330 OHM 5% 1/4W | |
| R453 | 40-27-0222 | FXD C FILM 22 OHM 5% 1/4W | |

For Service Manuals Contact
MAURITRON TECHNICAL SERVICES
8 Cherry Tree Rd, Chinnor
Oxon OX9 4QY
Tel: 01844-351694 Fax: 01844-352554
Email: enquiries@mauritron.co.uk

| REFERENCE DESIGNATOR | KIKUSUI PARTS NO. | DESCRIPTION | |
|----------------------|-------------------|--------------|------------------|
| R454 | 40-27-3472 | FXD C FILM | 47K OHM 5% 1/4W |
| R455 | 40-27-2182 | FXD C FILM | 1.8K OHM 5% 1/4W |
| R456 | 40-27-3102 | FXD C FILM | 10K OHM 5% 1/4W |
| R458 | 40-27-3102 | FXD C FILM | 10K OHM 5% 1/4W |
| R459 | 40-27-2562 | FXD C FILM | 5.6K OHM 5% 1/4W |
| R460 | 40-27-3472 | FXD C FILM | 47K OHM 5% 1/4W |
| R461 | 42-72-3220 | FXD M FILM | 22K OHM 1% 1/4W |
| R462 | 42-72-3330 | FXD M FILM | 33K OHM 1% 1/4W |
| R463 | 40-27-2272 | FXD C FILM | 2.7K OHM 5% 1/4W |
| R466 | 40-27-2102 | FXD C FILM | 1K OHM 5% 1/4W |
| R467 | 40-27-0472 | FXD C FILM | 47 OHM 5% 1/4W |
| R468 | 40-27-2222 | FXD C FILM | 2.2K OHM 5% 1/4W |
| R469 | 40-27-3102 | FXD C FILM | 10K OHM 5% 1/4W |
| R470 | 40-27-1822 | FXD C FILM | 820 OHM 5% 1/4W |
| R471 | 40-27-3562 | FXD C FILM | 56K OHM 5% 1/4W |
| R472 | 40-27-2222 | FXD C FILM | 2.2K OHM 5% 1/4W |
| R473 | 40-27-2122 | FXD C FILM | 1.2K OHM 5% 1/4W |
| R474 | * | - | - |
| R475 | 40-27-2392 | FXD C FILM | 3.9K OHM 5% 1/4W |
| R476 | 40-27-3182 | FXD C FILM | 18K OHM 5% 1/4W |
| R477 | 40-27-1222 | FXD C FILM | 220 OHM 5% 1/4W |
| R478 | 42-72-2220 | FXD M FILM | 2.2K OHM 1% 1/4W |
| R479 | 40-27-4472 | FXD C FILM | 470K OHM 5% 1/4W |
| R480 | 40-27-3102 | FXD C FILM | 10K OHM 5% 1/4W |
| R481 | 40-27-3332 | FXD C FILM | 33K OHM 5% 1/4W |
| R482 | 40-27-3102 | FXD C FILM | 10K OHM 5% 1/4W |
| R483 | 40-27-2472 | FXD C FILM | 4.7K OHM 5% 1/4W |
| R484 | 42-72-2160 | FXD M FILM | 1.6K OHM 1% 1/4W |
| R485 | 40-27-4102 | FXD C FILM | 100K OHM 5% 1/4W |
| R486 | 40-27-2332 | FXD C FILM | 3.3K OHM 5% 1/4W |
| R487 | 40-27-0102 | FXD C FILM | 10 OHM 5% 1/4W |
| R488 | 40-27-0102 | FXD C FILM | 10 OHM 5% 1/4W |
| R489 | 40-27-0102 | FXD C FILM | 10 OHM 5% 1/4W |
| R491 | 42-24-0231 | FXD M GLAZE | 5M OHM 1% 0.31W |
| R492 | 42-74-5100 | FXD M FILM | 1M OHM 1% 1/2W |
| R493 | 44-04-0010 | FXD M GLAZE | R-NETWORK |
| R494 | 42-72-2390 | FXD M FILM | 3.9K OHM 1% 1/4W |
| R495 | 42-72-1470 | FXD M FILM | 470 OHM 1% 1/4W |
| R496 | 40-27-3102 | FXD C FILM | 10K OHM 5% 1/4W |
| R498 | 40-27-1562 | FXD C FILM | 560 OHM 5% 1/4W |
| R499 | 40-27-1102 | FXD C FILM | 100 OHM 5% 1/4W |
| R501 | 40-27-2682 | FXD C FILM | 6.8K OHM 5% 1/4W |
| R502 | 40-27-1472 | FXD C FILM | 470 OHM 5% 1/4W |
| R503 | 42-72-0560 | FXD M FILM | 56 OHM 1% 1/4W |
| R504 | 40-27-2562 | FXD C FILM | 5.6K OHM 5% 1/4W |
| R505 | 40-27-2562 | FXD C FILM | 5.6K OHM 5% 1/4W |
| R506 | 40-27-2562 | FXD C FILM | 5.6K OHM 5% 1/4W |
| R507 | 40-27-2562 | FXD C FILM | 5.6K OHM 5% 1/4W |
| R508 | 42-72-2100 | FXD M FILM | 1K OHM 1% 1/4W |
| R509 | 42-72-2100 | FXD M FILM | 1K OHM 1% 1/4W |
| R510 | 42-72-2100 | FXD M FILM | 1K OHM 1% 1/4W |
| R511 | 42-72-2120 | FXD M FILM | 1.2K OHM 1% 1/4W |
| R512 | 40-27-1332 | FXD C FILM | 330 OHM 5% 1/4W |
| R513 | 40-27-1332 | FXD C FILM | 330 OHM 5% 1/4W |
| R514 | 40-27-3102 | FXD C FILM | 10K OHM 5% 1/4W |
| R515 | 40-27-4102 | FXD C FILM | 100K OHM 5% 1/4W |
| R516 | 40-27-2222 | FXD C FILM | 2.2K OHM 5% 1/4W |
| R517 | 40-27-2222 | FXD C FILM | 2.2K OHM 5% 1/4W |
| R518 | 42-72-4100 | FXD M FILM | 100K OHM 1% 1/4W |
| R519 | 42-72-4100 | FXD M FILM | 100K OHM 1% 1/4W |
| R520 | 40-27-4102 | FXD C FILM | 100K OHM 5% 1/4W |
| R521 | 40-27-4102 | FXD C FILM | 100K OHM 5% 1/4W |
| R522 | 40-27-2152 | FXD C FILM | 1.5K OHM 5% 1/4W |
| R523 | 40-27-1332 | FXD C FILM | 330 OHM 5% 1/4W |
| R524 | 40-27-2152 | FXD C FILM | 1.5K OHM 5% 1/4W |
| R525 | 40-27-1332 | FXD C FILM | 330 OHM 5% 1/4W |
| R526 | 40-27-0472 | FXD C FILM | 47 OHM 5% 1/4W |
| R527 | 40-27-0472 | FXD C FILM | 47 OHM 5% 1/4W |
| R528 | * | - | - |
| R651 | 42-72-2820 | FXD M FILM | 8.2K OHM 1% 1/4W |
| R652 | 42-72-3120 | FXD M FILM | 12K OHM 1% 1/4W |
| R653 | * | - | - |
| R654 | 42-72-3680 | FXD M FILM | 68K OHM 1% 1/4W |
| R655 | 40-27-2102 | FXD C FILM | 1K OHM 5% 1/4W |
| R656 | 40-27-0000 | JUMPER PARTS | |
| R657 | 44-91-0010 | FXD M OXIDE | 1 OHM 5% 1W |
| R658 | 40-27-2472 | FXD C FILM | 4.7K OHM 5% 1/4W |

KIKUSUI S8109011

| REFERENCE DESIGNATOR | KIKUSUI PARTS NO. | DESCRIPTION |
|----------------------|-------------------|-----------------------------|
| R659 | 40-27-1472 | FXD C FILM 470 OHM 5% 1/4W |
| R660 | 40-37-3221 | FXD C FILM 22K OHM 5% 1/2W |
| R661 | 40-37-5221 | FXD C FILM 2.2M OHM 5% 1/2W |
| R662 | 42-44-0300 | FXD M GLAZE 10M OHM 1% 2.5W |
| R663 | 40-27-2102 | FXD C FILM 1K OHM 5% 1/4W |
| R664 | 40-27-3102 | FXD C FILM 10K OHM 5% 1/4W |
| R665 | 40-37-5221 | FXD C FILM 2.2M OHM 5% 1/2W |
| R666 | 40-37-6101 | FXD C FILM 10M OHM 5% 1/2W |
| R667 | 40-37-6101 | FXD C FILM 10M OHM 5% 1/2W |
| R668 | 40-27-2332 | FXD C FILM 3.3K OHM 5% 1/4W |
| R669 | 40-37-5151 | FXD C FILM 1.5M OHM 5% 1/2W |
| R670 | 40-27-3102 | FXD C FILM 10K OHM 5% 1/4W |
| R671 | 40-27-4102 | FXD C FILM 100K OHM 5% 1/4W |
| R673 | 40-27-3102 | FXD C FILM 10K OHM 5% 1/4W |
| R674 | 40-37-6101 | FXD C FILM 10M OHM 5% 1/2W |
| R675 | 40-37-6101 | FXD C FILM 10M OHM 5% 1/2W |
| R676 | 40-37-5151 | FXD C FILM 1.5M OHM 5% 1/2W |
| R677 | 40-27-1102 | FXD C FILM 100 OHM 5% 1/4W |
| R678 | 40-27-1102 | FXD C FILM 100 OHM 5% 1/4W |
| R679 | 40-27-1102 | FXD C FILM 100 OHM 5% 1/4W |
| R680 | 40-27-4472 | FXD C FILM 470K OHM 5% 1/4W |
| R681 | 40-27-2182 | FXD C FILM 1.8K OHM 5% 1/4W |
| R683 | 40-27-2332 | FXD C FILM 3.3K OHM 5% 1/4W |
| R684 | 40-27-2222 | FXD C FILM 2.2K OHM 5% 1/4W |
| R685 | 40-27-1102 | FXD C FILM 100 OHM 5% 1/4W |
| R686 | 40-27-1222 | FXD C FILM 220 OHM 5% 1/4W |
| R687 | 40-27-2562 | FXD C FILM 5.6K OHM 5% 1/4W |
| R688 | 40-27-1332 | FXD C FILM 330 OHM 5% 1/4W |
| R689 | 40-27-2472 | FXD C FILM 4.7K OHM 5% 1/4W |
| R690 | 40-37-3471 | FXD C FILM 47K OHM 5% 1/2W |
| R691 | 40-37-3471 | FXD C FILM 47K OHM 5% 1/2W |
| R692 | 40-37-3471 | FXD C FILM 47K OHM 5% 1/2W |
| R693 | 40-27-1682 | FXD C FILM 680 OHM 5% 1/4W |
| R694 | 40-27-1682 | FXD C FILM 680 OHM 5% 1/4W |
| R695 | 40-37-3471 | FXD C FILM 47K OHM 5% 1/2W |
| R696 | 40-27-1102 | FXD C FILM 100 OHM 5% 1/4W |
| R697 | 40-27-4102 | FXD C FILM 100K OHM 5% 1/4W |
| R698 | * 40-27-3392 | FXD C FILM 39K OHM 5% 1/4W |
| R699 | 40-27-3562 | FXD C FILM 56K OHM 5% 1/4W |
| R702 | 40-27-2102 | FXD C FILM 1K OHM 5% 1/4W |
| R703 | 40-27-1472 | FXD C FILM 470 OHM 5% 1/4W |
| R704 | 40-27-2152 | FXD C FILM 1.5K OHM 5% 1/4W |
| R705 | 40-27-2102 | FXD C FILM 1K OHM 5% 1/4W |
| R706 | 40-27-2392 | FXD C FILM 3.9K OHM 5% 1/4W |
| R707 | 40-27-3182 | FXD C FILM 18K OHM 5% 1/4W |
| R708 | 40-27-3222 | FXD C FILM 22K OHM 5% 1/4W |
| R709 | 40-27-3562 | FXD C FILM 56K OHM 5% 1/4W |
| R710 | 40-27-3472 | FXD C FILM 47K OHM 5% 1/4W |
| R711 | 40-27-2102 | FXD C FILM 1K OHM 5% 1/4W |
| R712 | 40-27-0472 | FXD C FILM 47 OHM 5% 1/4W |
| R713 | 40-27-3102 | FXD C FILM 10K OHM 5% 1/4W |
| R714 | 42-72-3330 | FXD M FILM 33K OHM 1% 1/4W |
| R715 | 42-72-3220 | FXD M FILM 22K OHM 1% 1/4W |
| R716 | 40-27-2122 | FXD C FILM 1.2K OHM 5% 1/4W |
| R717 | 40-27-3182 | FXD C FILM 18K OHM 5% 1/4W |
| R718 | 40-27-2392 | FXD C FILM 3.9K OHM 5% 1/4W |
| R719 | 40-27-1222 | FXD C FILM 220 OHM 5% 1/4W |
| R720 | 42-72-2150 | FXD M FILM 1.5K OHM 1% 1/4W |
| R721 | 42-72-2220 | FXD M FILM 2.2K OHM 1% 1/4W |
| R722 | 40-27-2562 | FXD C FILM 5.6K OHM 5% 1/4W |
| R723 | 40-27-2562 | FXD C FILM 5.6K OHM 5% 1/4W |
| R724 | 44-25-0000 | FXD M GLAZE R-NETWORK |
| R725 | 40-27-0102 | FXD C FILM 10 OHM 5% 1/4W |
| R730 | 40-27-2182 | FXD C FILM 1.8K OHM 5% 1/4W |
| R1401 | 40-27-2102 | FXD C FILM 1K OHM 5% 1/4W |
| R1403 | 40-27-2102 | FXD C FILM 1K OHM 5% 1/4W |
| R1404 | 40-27-4472 | FXD C FILM 470K OHM 5% 1/4W |
| R1405 | 40-27-2102 | FXD C FILM 1K OHM 5% 1/4W |
| R1652 | 40-27-3152 | FXD C FILM 15K OHM 5% 1/4W |
| R1654 | 40-27-2332 | FXD C FILM 3.3K OHM 5% 1/4W |
| RU401 | 48-33-2500 | VAR M FILM 5K OHM |
| RU404 | 48-33-4500 | VAR M FILM 500K OHM |
| RU405 | 48-33-3100 | VAR M FILM 10K OHM |
| RU451 | 48-36-5220 | VAR M GLAZE 2.2M OHM |
| RU452 | 48-33-4100 | VAR M FILM 100K OHM |
| RU453 | 48-33-3200 | VAR M FILM 20K OHM |

KIKUSUI S8109021

For Service Manuals Contact
MAURITRON TECHNICAL SERVICES
 8 Cherry Tree Rd, Chinnor
 Oxon OX9 4QY
 Tel: 01844-351694 Fax: 01844-352554
 Email: enquiries@mauritron.co.uk

| REFERENCE DESIGNATOR | KIKUSUI PARTS NO. | DESCRIPTION |
|----------------------|-------------------|-------------------------------------|
| RV702 | 48-33-2100 | VAR M FILM 1K OHM |
| RV703 | 48-33-2200 | VAR M FILM 2K OHM |
| C401 | 52-05-2468 | FXD CER 0.01UF +80-20% 50V TYPE2 |
| C402 | 50-67-0040 | FXD PLSTC FILM 0.022UF 10% 100V |
| C403 | 52-06-3185 | FXD CER 47PF 10% 500V TYPE1 |
| C404 | 52-06-3185 | FXD CER 47PF 10% 500V TYPE1 |
| C405 | * 52-06-3185 | FXD CER 47PF 10% 500V TYPE1 |
| C406 | 54-00-0114 | FXD ELECT 47UF 25V |
| C407 | 54-00-0114 | FXD ELECT 47UF 25V |
| C408 | 54-00-0311 | FXD ELECT 10UF 50V |
| C409 | 54-00-0311 | FXD ELECT 10UF 50V |
| C410 | 54-00-0311 | FXD ELECT 10UF 50V |
| C411 | * | |
| C431 | 55-37-2050 | FXD TANT ELECT 1UF 35V |
| C432 | 54-00-0311 | FXD ELECT 10UF 50V |
| C433 | 50-67-0030 | FXD PLSTC FILM 0.01UF 10% 100V |
| C451 | 52-06-3185 | FXD CER 47PF 10% 500V TYPE1 |
| C452 | 54-00-0114 | FXD ELECT 47UF 25V |
| C454 | 52-01-3345 | FXD CER 1000PF 10% 500V TYPE2 |
| C455 | 52-06-3185 | FXD CER 47PF 10% 500V TYPE1 |
| C457 | 54-00-0114 | FXD ELECT 47UF 25V |
| C458 | 52-06-2225 | FXD CER 100PF 10% 50V TYPE1 |
| C459 | 50-65-0530 | FXD M PLSTC FILM 1000PF 5% 100V |
| C460 | 50-65-0540 | FXD M PLSTC FILM 1UF 5% 100V |
| C461 | 54-00-0114 | FXD ELECT 47UF 25V |
| C462 | 52-05-2468 | FXD CER 0.01UF +80-20% 50V TYPE2 |
| C463 | 54-00-0311 | FXD ELECT 10UF 50V |
| C464 | 54-00-0311 | FXD ELECT 10UF 50V |
| C465 | 52-06-3125 | FXD CER 15PF 10% 500V TYPE1 |
| C467 | 52-01-3345 | FXD CER 1000PF 10% 500V TYPE2 |
| C468 | 50-67-0030 | FXD PLSTC FILM 0.01UF 10% 100V |
| C469 | 52-05-2468 | FXD CER 0.01UF +80-20% 50V TYPE2 |
| C503 | 52-03-3469 | FXD CER 0.01UF +100-0% 500V TYPE2 |
| C504 | 52-03-3469 | FXD CER 0.01UF +100-0% 500V TYPE2 |
| C506 | 52-03-3469 | FXD CER 0.01UF +100-0% 500V TYPE2 |
| C507 | 52-03-3469 | FXD CER 0.01UF +100-0% 500V TYPE2 |
| C508 | 54-00-0311 | FXD ELECT 10UF 50V |
| C509 | 52-03-3469 | FXD CER 0.01UF +100-0% 500V TYPE2 |
| C510 | 54-00-0311 | FXD ELECT 10UF 50V |
| C511 | * | |
| C651 | 54-00-0311 | FXD ELECT 10UF 50V |
| C652 | 54-00-0311 | FXD ELECT 10UF 50V |
| C653 | 52-01-3365 | FXD CER 1500PF 10% 50V TYPE2 |
| C654 | 50-67-0040 | FXD PLSTC FILM 0.022UF 10% 100V |
| C655 | 54-00-0312 | FXD ELECT 22UF 50V |
| C656 | 55-37-2050 | FXD TANT ELECT 1UF 35V |
| C657 | 52-98-1000 | FXD CER 4700PF +80-20% 3.15KV TYPE1 |
| C658 | 52-98-1000 | FXD CER 4700PF +80-20% 3.15KV TYPE1 |
| C659 | 52-98-1000 | FXD CER 4700PF +80-20% 3.15KV TYPE1 |
| C660 | 52-98-1010 | FXD CER 1000PF +80-20% 6.3KV TYPE1 |
| C661 | 52-98-1010 | FXD CER 1000PF +80-20% 6.3KV TYPE1 |
| C662 | 52-98-1010 | FXD CER 1000PF +80-20% 6.3KV TYPE1 |
| C663 | 52-98-1010 | FXD CER 1000PF +80-20% 6.3KV TYPE1 |
| C664 | 52-03-3469 | FXD CER 0.01UF +100-0% 500V TYPE2 |
| C665 | 52-98-1010 | FXD CER 1000PF +80-20% 6.3KV TYPE1 |
| C666 | 52-98-1010 | FXD CER 1000PF +80-20% 6.3KV TYPE1 |
| C667 | 52-98-1000 | FXD CER 4700PF +80-20% 3.15KV TYPE1 |
| C668 | 52-08-5145 | FXD CER 22PF 10% 2KV TYPE1 |
| C669 | 50-67-0040 | FXD PLSTC FILM 0.022UF 10% 100V |
| C681 | 52-05-2468 | FXD CER 0.01UF +80-20% 50V TYPE2 |
| C682 | 52-06-2265 | FXD CER 220PF 10% 50V TYPE1 |
| C683 | 54-00-0311 | FXD ELECT 10UF 50V |
| C684 | 54-00-0311 | FXD ELECT 10UF 50V |
| C685 | 52-03-3469 | FXD CER 0.01UF +100-0% 500V TYPE2 |
| C686 | 54-00-0311 | FXD ELECT 10UF 50V |
| C687 | 52-03-3469 | FXD CER 0.01UF +100-0% 500V TYPE2 |
| C688 | 52-05-2468 | FXD CER 0.01UF +80-20% 50V TYPE2 |
| C689 | 52-05-2468 | FXD CER 0.01UF +80-20% 50V TYPE2 |
| C701 | 52-06-3185 | FXD CER 47PF 10% 500V TYPE1 |
| C702 | 50-65-0530 | FXD M PLSTC FILM 1000PF 5% 100V |
| C703 | 52-05-2468 | FXD CER 0.01UF +80-20% 50V TYPE2 |
| C704 | 54-00-0311 | FXD ELECT 10UF 50V |
| C705 | 54-00-0311 | FXD ELECT 10UF 50V |
| C707 | 52-05-2468 | FXD CER 0.01UF +80-20% 50V TYPE2 |
| DS651 | 23-70-0000 | LAMP NEON |

| REFERENCE DESIGNATOR | KIKUSUI PARTS NO. | DESCRIPTION | |
|----------------------|-------------------|-----------------------------------|----------------------|
| DS652 | 23-70-0000 | LAMP NEON | |
| L650 | 67-10-0890 | INDUCTOR 100UH 10% | |
| S401 | 82-70-5242 | LEVER SWITCH | ALPS SLR524-2 |
| S402 | 82-70-5242 | LEVER SWITCH | ALPS SLR524-2 |
| S403 | 82-70-5222 | PUSH SWITCH | ALPS SLR522-2 |
| S406 | 80-98-0610 | SW ROTARY WITH RV A SWEEP/DIV | ALPS S21P 2421/RV |
| S701 | 80-98-0620 | SW ROTARY B SWEEP/DIV | ALPS S21P 1111/RV |
| T651 | 63-92-0130 | CONVERTOR TRANS | KIKUSUI S810115 |
| A4 ASSEMBLY | | | |
| CR1601 | 32-92-0360 | ZENER VZ=35.3-36.8V | HITACHI HZ36L-2 |
| CR1602 | 32-92-0360 | ZENER VZ=35.3-36.8V | HITACHI HZ36L-2 |
| CR1603 | 32-92-0360 | ZENER VZ=35.3-36.8V | HITACHI HZ36L-2 |
| CR1604 | 32-92-0360 | ZENER VZ=35.3-36.8V | HITACHI HZ36L-2 |
| CR1605 | 37-00-0060 | LAMP LED GREEN | TOSHIBA TLE-105 |
| Q1601 | 30-31-8461 | TR SI NPN | MATSUSHITA 2SC1846-R |
| Q1602 | 30-31-8461 | TR SI NPN | MATSUSHITA 2SC1846-R |
| U1601 | 35-60-0000 | QUAD 2-INPUT NAND GATES | TOSHIBA TC4011BP |
| R1601 | * 40-27-4102 | FXD C FILM 100K OHM 5% 1/4W | |
| R1602 | 40-27-3102 | FXD C FILM 10K OHM 5% 1/4W | |
| R1603 | 40-27-3102 | FXD C FILM 10K OHM 5% 1/4W | |
| R1604 | 40-27-4102 | FXD C FILM 100K OHM 5% 1/4W | |
| R1605 | 40-27-4102 | FXD C FILM 100K OHM 5% 1/4W | |
| R1606 | 40-27-4222 | FXD C FILM 220K OHM 5% 1/4W | |
| R1607 | 40-27-4472 | FXD C FILM 470K OHM 5% 1/4W | |
| R1608 | 40-27-4472 | FXD C FILM 470K OHM 5% 1/4W | |
| R1609 | 40-27-1472 | FXD C FILM 470 OHM 5% 1/4W | |
| R1610 | 42-72-3100 | FXD M FILM 10K OHM 1% 1/4W | |
| R1611 | * 40-27-4102 | FXD C FILM 100K OHM 5% 1/4W | |
| R1612 | 42-72-2200 | FXD M FILM 2K OHM 1% 1/4W | |
| R1613 | 40-27-0102 | FXD C FILM 10 OHM 5% 1/4W | |
| R1614 | 40-27-1682 | FXD C FILM 680 OHM 5% 1/4W | |
| R1615 | 40-27-1102 | FXD C FILM 100 OHM 5% 1/4W | |
| R1616 | 40-27-1562 | FXD C FILM 560 OHM 5% 1/4W | |
| RV706 | 45-43-3100 | VAR M GLAZE 10K OHM | |
| RV1601 | 45-44-3100 | VAR C COMP 10K OHM | |
| RV1603 | 45-44-4200 | VAR C COMP 200K OHM | |
| RV1604 | 45-43-2200 | VAR M GLAZE 2K OHM | |
| RV1605 | 45-44-3100 | VAR C COMP 10K OHM | |
| C1605 | 50-45-0500 | FXD PLSTC FILM 0.01MF 5% 50V | |
| C1606 | 50-45-0500 | FXD PLSTC FILM 0.01MF 5% 50V | |
| C1607 | 52-06-3051 | FXD CER 5PF 10% 500V TYPE1 | |
| C1608 | 52-01-3345 | FXD CER 1000PF 10% 500V TYPE2 | |
| C1609 | 54-00-0114 | FXD ELECT 47UF 25V | |
| C1610 | 52-03-3469 | FXD CER 0.01UF +100-0% 500V TYPE2 | |
| DS1601 | 23-44-0000 | LAMP 14V 80MA | |
| DS1602 | 23-44-0000 | LAMP 14V 80MA | |
| B ASSEMBLY | | | |
| CR409 | 37-00-0082 | LAMP LED RED | TOSHIBA TLR102KW |
| CR451 | 32-11-5880 | DIODE VR=30V IO=120MA | TOSHIBA 1S1588 |
| R101 | 40-27-0472 | FXD C FILM 47 OHM 5% 1/4W | |
| R201 | 40-27-0472 | FXD C FILM 47 OHM 5% 1/4W | |
| R426 | 40-27-2822 | FXD C FILM 8.2K OHM 5% 1/4W | |
| R457 | 40-27-3102 | FXD C FILM 10K OHM 5% 1/4W | |
| R731 | 44-07-0020 | FXD M GLAZE RESISTOR NETWORKS | 10K OHM X4 |
| R1402 | 40-27-0562 | FXD C FILM 56 OHM 5% 1/4W | |
| RV111 | 45-01-0700 | VAR C COMP 10K OHM WITH SW | |
| RV211 | 45-01-0700 | VAR C COMP 10K OHM WITH SW | |
| RV402 | 45-01-0550 | VAR C COMP 10K/100K OHM B | |
| RV501 | 45-35-3103 | VAR C COMP 10K OHM | |
| C453 | 52-01-3345 | FXD CER 1000PF 10% 500V TYPE2 | |
| C466 | 52-05-1498 | FXD CER 0.1UF +80-20% 25V TYPE2 | |
| C601 | 52-77-1000 | FXD CER 100PF 250VAC | |
| C602 | 52-77-1000 | FXD CER 100PF 250VAC | |

| REFERENCE DESIGNATOR | KIKUSUI PARTS NO. | DESCRIPTION | |
|----------------------|-------------------|-------------|------------------|
| S404 | 81-03-0270 | PUSH SWITCH | ALPS SUE30 |
| S702 | 81-04-0260 | PUSH SWITCH | ALPS SUE40 |
| S1601 | 81-01-0270 | PUSH SWITCH | ALPS SDG5P-E |
| T601 | 60-44-0110 | POWER TRANS | KIKUSUI S820041 |
| V601 | 21-16-0601 | CRT | TOSHIBA 150BTB31 |

For Service Manuals Contact
MAURITRON TECHNICAL SERVICES
 8 Cherry Tree Rd, Chinnor
 Oxon OX9 4QY
 Tel:- 01844-351694 Fax:- 01844-352554
 Email:- enquiries@mauritron.co.uk

| NO. | NAME | QTY | CODE NO. |
|-----|-----------------------------|-----|------------|
| 14 | | | |
| 13 | PUSH BUTTON 7.5 x 5.5 BRN | 1 | P2-000-371 |
| 12 | BEZEL FOR PUSH BUTTON | 8 | P2-000-331 |
| 11 | PUSH BUTTON 7.5 x 5.5 | 7 | P2-000-321 |
| 10 | KNOB R14WR | 1 | R2-000-061 |
| 9 | KNOB R12MR - 2.5 | 2 | R2-000-051 |
| 8 | KNOB R12MRG - 2.5 | 1 | R1-001-131 |
| 7 | KNOB R13SG - K | 6 | R1-001-121 |
| 6 | KNOB R10SEG - 3.2 | 1 | R1-001-101 |
| 5 | KNOB R14KG | 1 | R1-001-071 |
| 4 | KNOB D18MG | 3 | R1-001-061 |
| 3 | KNOB D22MG | 1 | R1-001-031 |
| 2 | COLLAR 9.2 - 4 - 12 | 1 | L2-000-091 |
| 1 | FRONT PANEL COS5021 COS5041 | 1 | A1-507-401 |

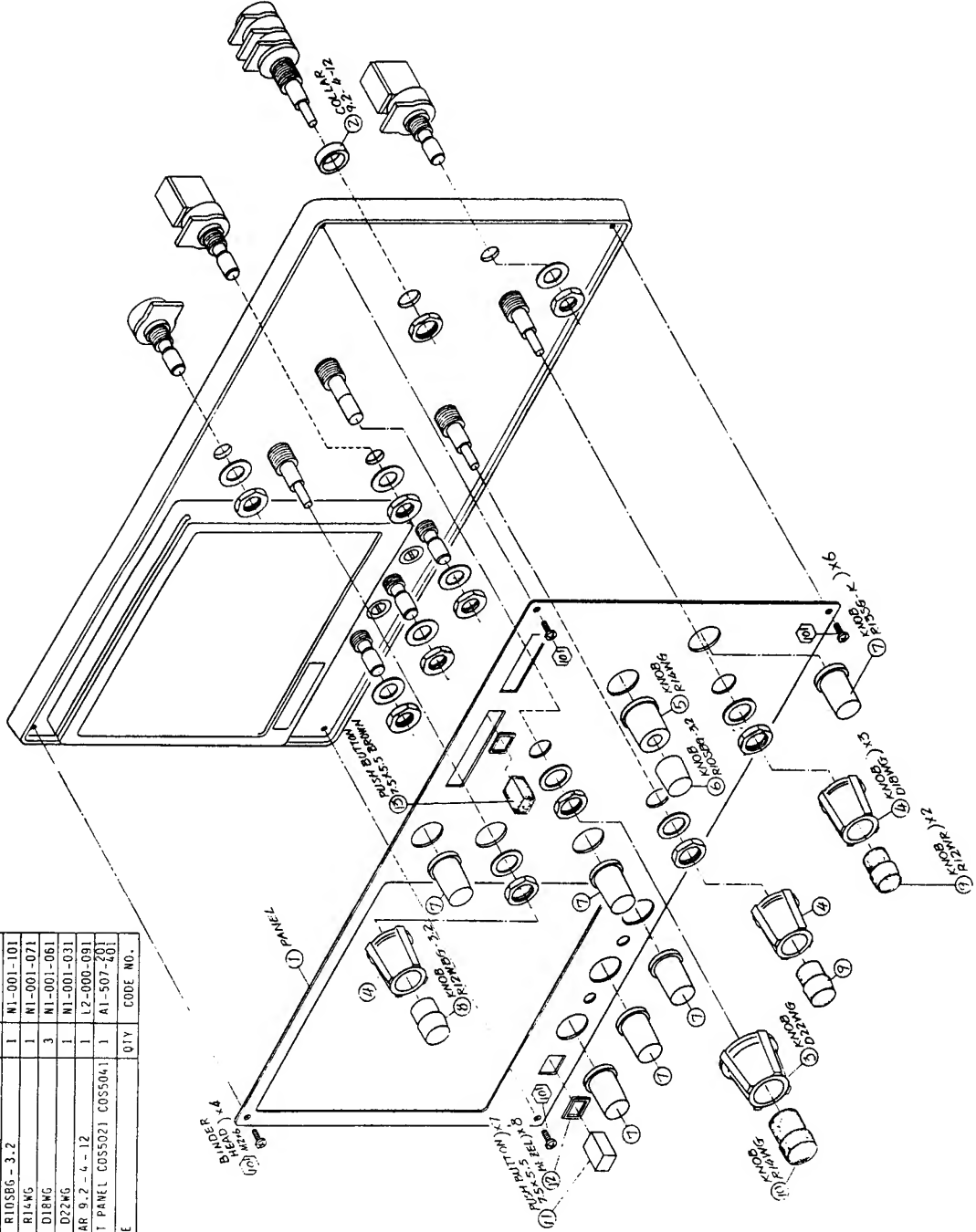

For Service Manuals Contact
MAURITRON TECHNICAL SERVICES
 8 Cherry Tree Rd, Chinnor
 Oxon OX9 4QY
 Tel: 01844-351694 Fax: 01844-352554
 Email: enquiries@maurtron.co.uk

| NO. | NAME | QTY | CODE NO. |
|-----|------------------------------|-----|------------|
| 101 | BINDING HEAD SCREW M2x6 B-NI | 4 | M2-000-021 |
| 102 | | | |
| 103 | | | |
| 104 | | | |
| 105 | | | |

| | | | |
|-----|-----------------------------|-----|------------|
| 105 | | | |
| 104 | | | |
| 103 | | | |
| 102 | | | |
| 101 | BINDER HEAD SCREW M2x6 B-NI | 4 | M2-000-021 |
| NO. | NAME | QTY | CODE NO. |

| | | | |
|-----|-----------------------|-----|------------|
| 14 | | | |
| 13 | | | |
| 12 | | | |
| 11 | BEZEL FOR PUSH BUTTON | 4 | P2-000-331 |
| 10 | PUSH BUTTON 7.5 x 5.5 | 4 | P2-000-321 |
| 9 | KNOB R12MR - 2.5 | 2 | M2-000-051 |
| 8 | KNOB R13SG - K | 7 | M1-001-121 |
| 7 | KNOB R10SBG - 3.2 | 1 | M1-001-101 |
| 6 | KNOB R14WG | 1 | M1-001-071 |
| 5 | KNOB D19MG | 2 | M1-001-061 |
| 4 | KNOB D22SG | 1 | M1-001-021 |
| 3 | COLLAR 7 - 1.8 - 8.8 | 1 | L2-507-101 |
| 2 | COLLAR 9.2 - 4 - 12 | 1 | L2-000-091 |
| 1 | FRONT COVER COSSO20 | 1 | A1-507-301 |
| NO. | NAME | QTY | CODE NO. |

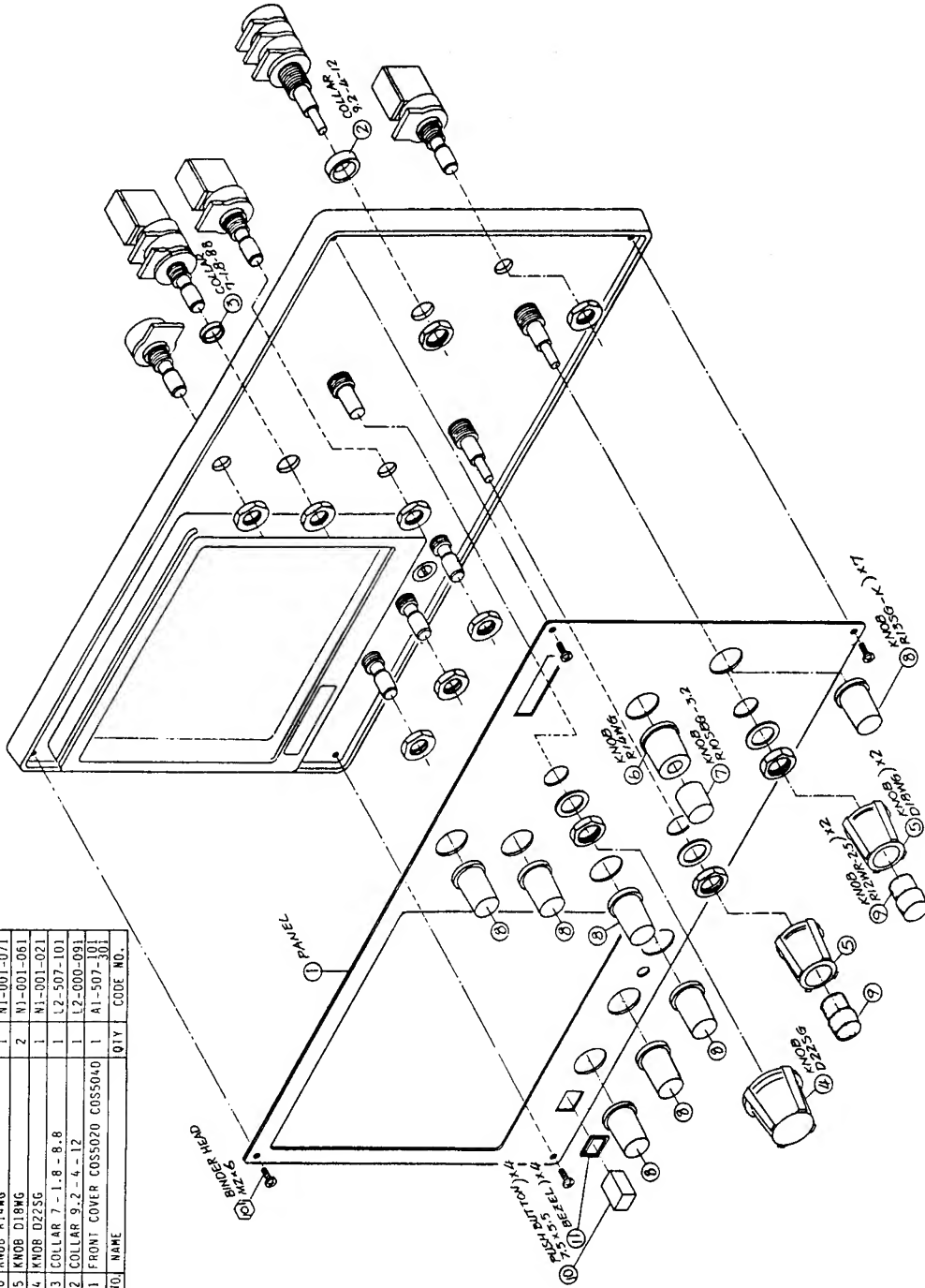

FRONT PANEL ASSEMBLY
(COS 5020, COS 5040)

316098

| | | | |
|----|------------------------|-------|------------|
| 15 | | | |
| 14 | | | |
| 13 | | | |
| 12 | | | |
| 11 | | | |
| 10 | RUBBER TAPE 7 x 40 x 5 | 1 | R3-050-041 |
| 9 | WASHER FOR SW | 6 | 09-507-101 |
| 8 | CORNER RUBBER FOR CRT | 4 | P5-502-101 |
| 7 | SWAP BUSHING 6D1A | 1+(0) | P4-000-771 |
| 6 | REFLECTOR | 1 | P3-507-101 |
| 5 | LOCAL TERMINAL | 1 | P2-000-291 |
| 4 | TERMINAL GND SHORT | 1 | L4-000-021 |
| 3 | SW GUIDE PIN | 3 | L3-506-702 |
| 2 | FRONT FRAME | 1 | B9-050-151 |
| 1 | NAME PLATE KIKUSUI | 1 | A8-000-621 |
| | NO. NAME | QTY | CODE NO. |

| | | | |
|-----|-------------------------------|-----|------------|
| 105 | EARTH LUG 6D1A | 1 | M6-000-151 |
| 104 | SPRING WASHER M*SW | 1 | M5-011-041 |
| 103 | NUT M4H | 1 | M4-011-041 |
| 102 | FLAT HEAD SCREW TAPPING 2.6x6 | 2 | M2-001-401 |
| 101 | FLAT HEAD SCREW M2.6 x 6 | 3 | M2-001-041 |
| | NO. NAME | QTY | CODE NO. |

For Service Manuals Contact
MAURITRON TECHNICAL SERVICES
 8 Cherry Tree Rd, Chinnor
 Oxon OX9 4QY
 Tel: 01844-351694 Fax: 01844-352554
 Email: enquiries@mauritron.co.uk

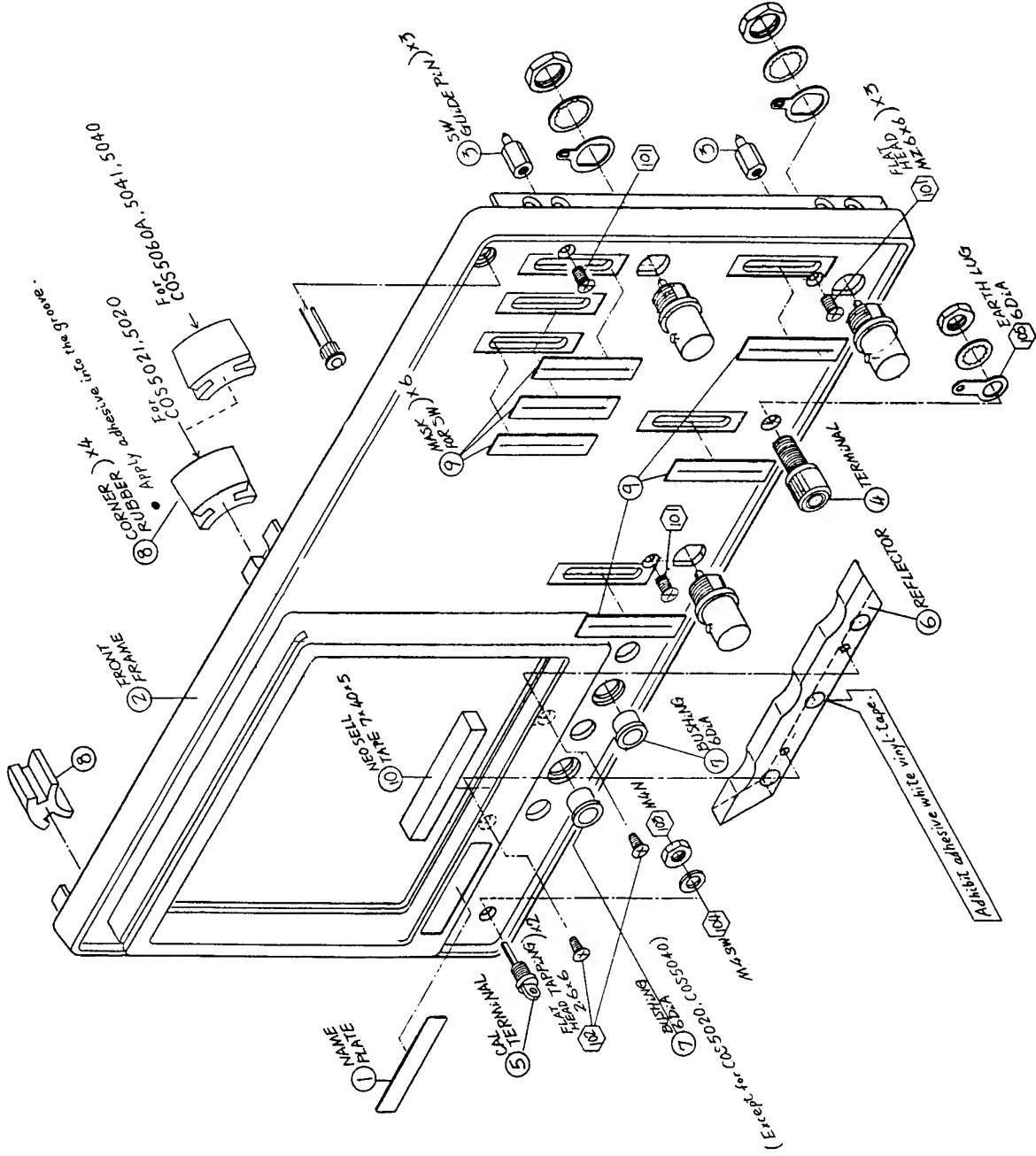

FRONT FRAME ASSEMBLY
 (COMMON DRAWING)

| | | | | |
|-----|-------------------------------|-----|------------|--|
| 110 | | | | |
| 109 | ASSEMBLED SCREW-PW M3X6 B-NI | 1 | M3-000-011 | |
| 108 | FLANGE NUT M4FN | 4 | M4-010-031 | |
| 107 | FLANGE NUT M3FN | 3 | M4-010-021 | |
| 106 | ASSEMBLED SCREW-SW M4 x 14 | 4 | M3-011-101 | |
| 105 | ASSEMBLED SCREW-PW M4x10 B-NI | 4 | M3-000-061 | |
| 104 | ASSEMBLED SCREW-PW M3x8 B-NI | 2 | M3-000-041 | |
| 103 | ASSEMBLED SCREW-PW M3x10 B-NI | 2 | M3-000-051 | |
| 102 | ASSEMBLED SCREW-PW M4x8 B-NI | 3 | M3-000-021 | |
| 101 | FLAT HEAD SCREW M3 x 6 | 6 | M2-001-081 | |
| NO. | NAME | QTY | CODE NO. | |

COSS5020 .5021 .5040 .5041

| | | | | |
|-----|---------------------|-----|------------|--|
| | | | | |
| | | | | |
| 7 | DOMED PLUG DP-312 | 1 | P4-050-081 | |
| 1-1 | REAR PLATE COSS5020 | 1 | B6-507-101 | |
| NO. | NAME | QTY | CODE NO. | |

FOR COSS5060/COSS5060A ONLY

| | | | | |
|-----|---------------------|-----|------------|--|
| | | | | |
| | | | | |
| 5 | ROUND KNOB R135G-K | 1 | M1-001-121 | |
| 1-2 | REAR PLATE COSS5060 | 1 | B6-507-501 | |
| NO. | NAME | QTY | CODE NO. | |

| | | | | |
|-----|------------------------|-----|------------|--|
| | | | | |
| | | | | |
| 8 | PLATE VOLTAGE SELECTOR | 1 | Q2-800-191 | |
| 6 | HOLDER CORD 3M | 4 | P3-000-101 | |
| 4 | STAY C-U | 1 | D5-507-103 | |
| 3 | STAY L-L | 2 | D5-507-102 | |
| 2 | STAY R-L | 1 | D5-507-101 | |
| NO. | NAME | QTY | CODE NO. | |

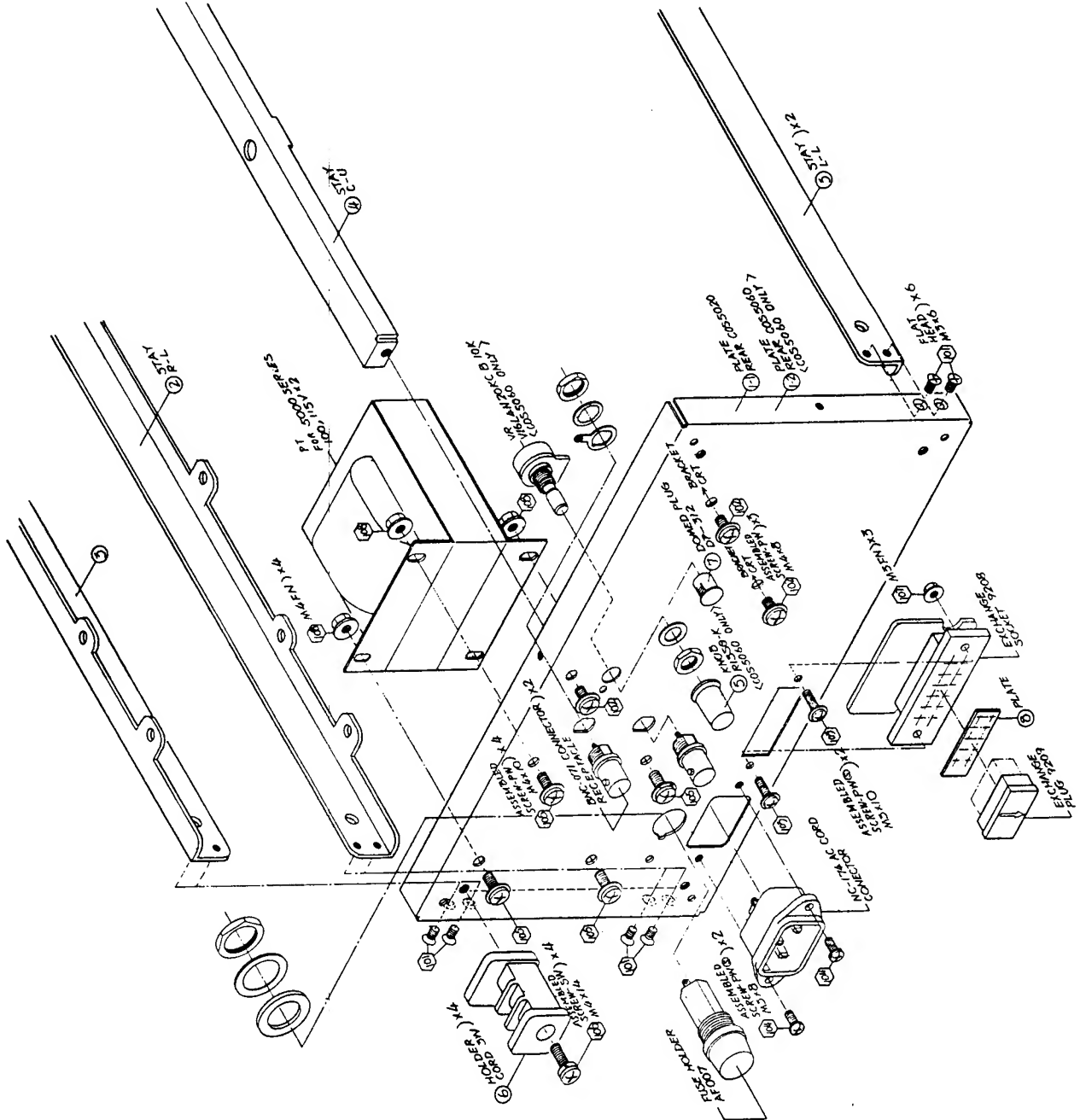

REAR PLATE ASSEMBLY
(COMMON DRAWING)

| NO. | NAME | QTY | CODE NO. |
|-----|----------------------------------|-----|----------|
| 12 | | | |
| 11 | | | |
| 10 | | | |
| 9 | | | |
| 8 | ADHESIVE TAPE ACETATE 571S 260mm | 14 | 000-131 |
| 7 | ADHESIVE TAPE ALUMI B33S 310mm | 4 | 000-121 |
| 6 | ADHESIVE TAPE M-20 120mm | 2 | 000-091 |
| 5 | SPACER 20 x 65 x 3 | 4 | 050-051 |
| 4 | SK-BINDER SKB-3 | 1 | 000-571 |
| 3 | BRACKET FOR R-COIL | 2 | 507-102 |
| 2 | BRACKET CRT | 2 | 507-101 |
| 1 | SHIELD CRT | 1 | 507-101 |

| NO. | NAME | QTY | CODE NO. |
|-----|--------------------------|-----|------------|
| 106 | | | |
| 105 | | | |
| 104 | | | |
| 103 | U-TYPE SPEED NUT | 6 | M8-000-391 |
| 102 | BINDER HEAD TAPPING 3x16 | 4 | M2-014-051 |
| 101 | BINDER HEAD TAPPING 3x10 | 2 | M2-014-031 |

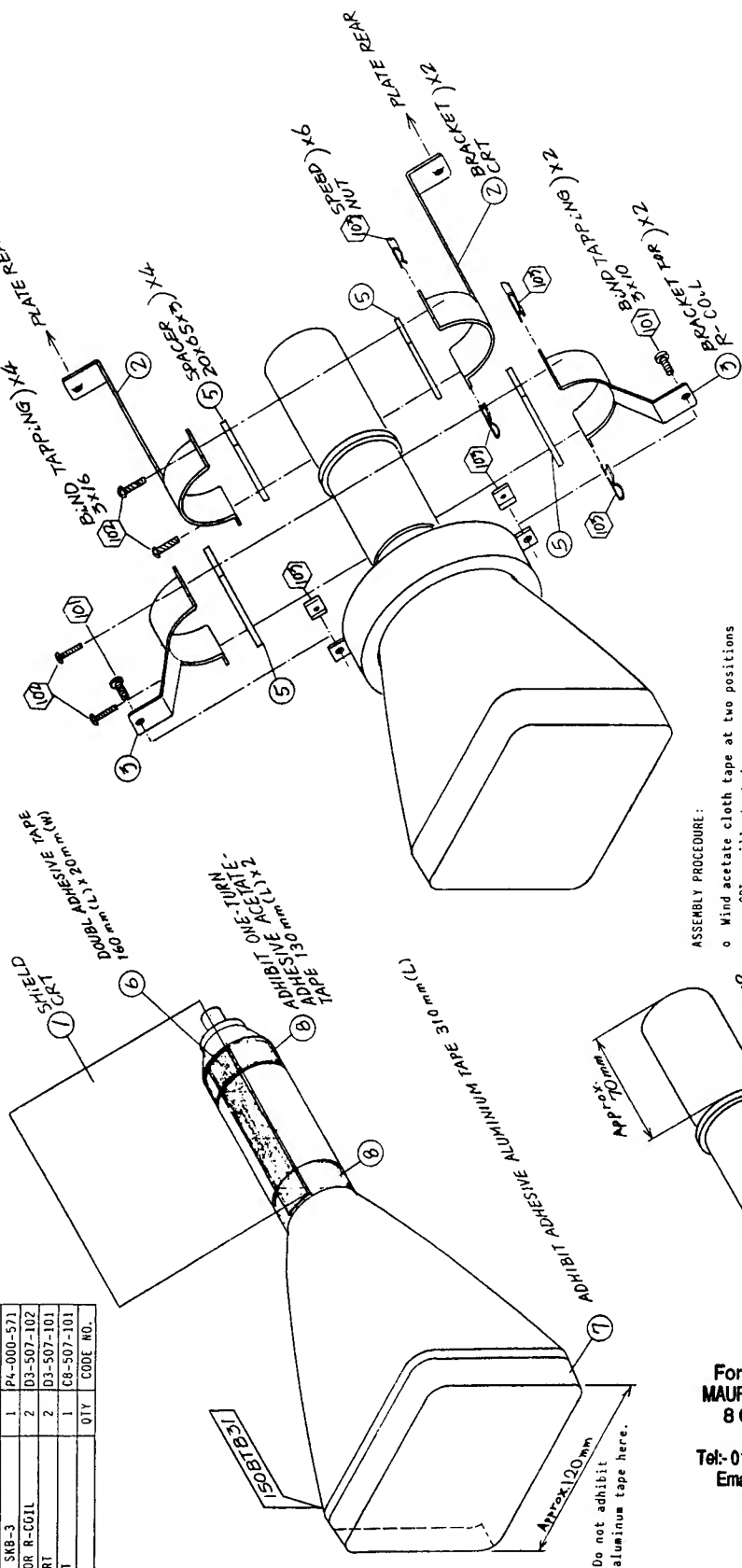

ASSEMBLY PROCEDURE:

- o Wind acetate cloth tape at two positions on CRT as illustrated.
- o Post double-faced tape as illustrated.
- o Put shield plate end on double-faced tape as illustrated, and wind shield board on CRT, exercising care so that no gaps are formed. (Wind shield plate in such position that 2 - 3 mm of acetate tape is visible from shield plate end.)
- o Clamp shield plate with SK binder as illustrated.

For Service Manuals Contact
MAURITRON TECHNICAL SERVICES
 8 Cherry Tree Rd, Chinnor
 Oxon OX9 4QY
 Tel:- 01844-351694 Fax:- 01844-352554
 Email:- enquiries@mauritron.co.uk

| | | | | |
|-----|----------------------------|-----|------------|--|
| 5 | | | | |
| 4 | | | | |
| 3 | 10-220 D-4 BFG-45 | 4 | X1-000-241 | |
| 2 | HEAT SINK | 2 | H1-505-801 | |
| 1 | SHIELD PLATE 30 x 80 x 0.3 | 1 | C9-050-131 | |
| NO. | NAME | QTY | CODE NO. | |

| | | | | |
|------|----------------------------|-----|------------|--|
| 1110 | | | | |
| 109 | | | | |
| 108 | | | | |
| 107 | | | | |
| 106 | | | | |
| 105 | FLANGE NUT M3FM | 3 | M4-010-021 | |
| 104 | WASHER M3PM | 3 | M5-000-091 | |
| 103 | ASSEMBLED SCREW-SWCPM M3x8 | 4 | M1-017-021 | |
| 102 | ASSEMBLED SCREW-SW M3 x 10 | 3 | M3-011-031 | |
| 101 | BINDER HEAD TAPPING 3x8 | 4 | M2-014-021 | |
| NO. | NAME | QTY | CODE NO. | |

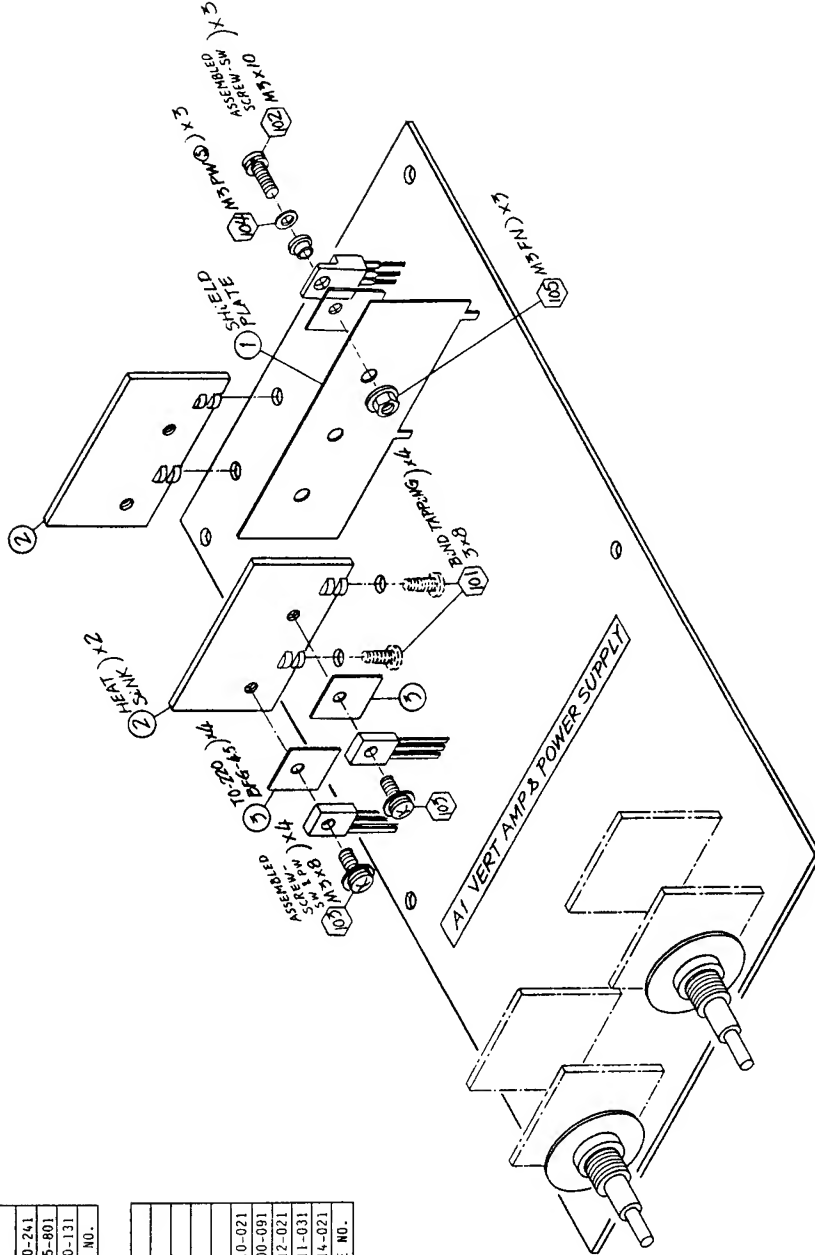

CIRCUIT BOARD ASSEMBLY
(VERTICAL)

| NO. | NAME | QTY | CODE NO. |
|-----|-----------------------|-----|------------|
| 5 | | | |
| 4 | | | |
| 3 | | | |
| 2 | IC-7425-S1 HEAT SINK | 1 | M2-000-181 |
| 1 | SHIELD BOX FOR DD-CON | 1 | EB-505-601 |

| NO. | NAME | QTY | CODE NO. |
|-----|------------------------------|-----|------------|
| 105 | | | |
| 104 | WASHER M3PM | 1 | M5-000-091 |
| 103 | ASSEMBLED SCREW-SWEPW M3 x 6 | 3 | M3-012-011 |
| 102 | ASSEMBLED SCREW-SM M3 x 10 | 1 | M3-011-031 |

FOR COSS040.504.1 ONLY

| NO. | NAME | QTY | CODE NO. |
|-----|--------------------------|-----|------------|
| 110 | NUT M2.6N | 4 | M4-000-021 |
| 109 | SPRING WASHER M2.6SW | 4 | M5-001-021 |
| 108 | WASHER M2.6PW | 4 | M5-000-021 |
| 107 | BINDER HEAD SCREW M2.6x8 | 4 | M2-000-051 |

FOR COSS040.504.1 ONLY

| NO. | NAME | QTY | CODE NO. |
|-----|--------------------------|-----|------------|
| 9 | | | |
| 8 | BUSHING RUBBER BU-687EXS | 1 | P4-000-781 |
| 7 | H.V. UNIT CASE | 1 | P1-050-041 |

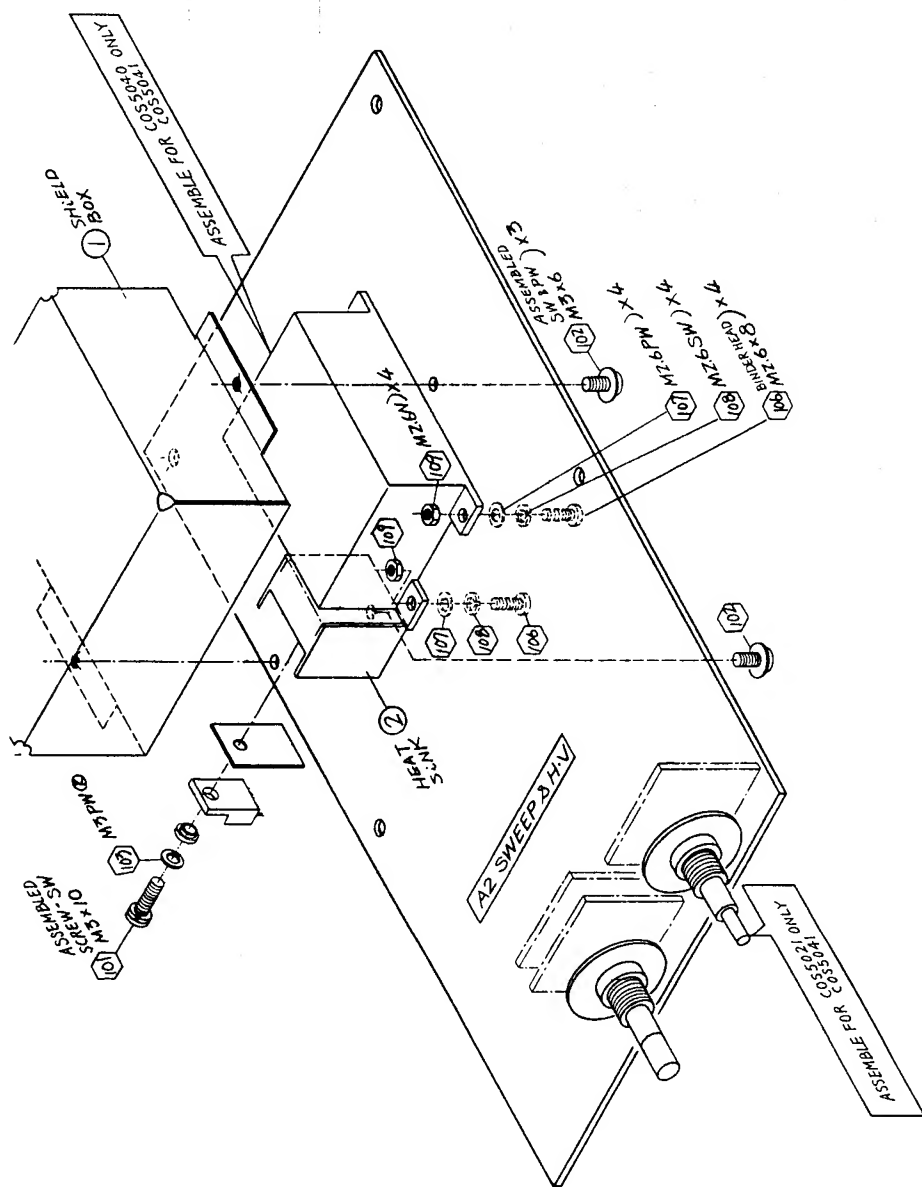

CIRCUIT BOARD ASSEMBLY
(TIME-BASE)
316106

For Service Manuals Contact
MAURITRON TECHNICAL SERVICES
8 Cherry Tree Rd, Chinnor
Oxon OX9 4QY
Tel: 01844-351694 Fax: 01844-352554
Email: enquiries@mauritron.co.uk

| NO. | NAME | QTY | CODE NO. |
|-----|---------------------------|-----|------------|
| 10 | | | |
| 9 | | | |
| 8 | | | |
| 7 | | | |
| 6 | | | |
| 5 | SHEET 14.5 x 128 | 1 | 01-507-101 |
| 4 | NYLON LOCKING SPACER 3670 | 6 | P4-507-101 |
| 3 | SPACER HEX 3-16.8 | 3 | 13-507-101 |
| 2 | SPACER HEX 3-13.5 | 1 | 13-021-041 |
| 1 | BRACKET FOR PCB | 1 | 03-507-103 |

| NO. | NAME | QTY | CODE NO. |
|-----|-------------------------------|-----|------------|
| 110 | | | |
| 109 | | | |
| 108 | | | |
| 107 | SPRING WASHER M3SW | 1 | M5-011-031 |
| 106 | LOCK WASHER M3LW | 4 | M5-007-001 |
| 105 | FLANGE NUT M3FN | 4 | M6-010-011 |
| 104 | ASSEMBLED SCREW-SWEPW M3 x 6 | 4 | M3-012-011 |
| 103 | ASSEMBLED SCREW-SW M3 x 6 | 1 | M3-011-011 |
| 102 | FLAT HEAD SCREW M3 x 4 | 6 | M2-001-071 |
| 101 | BINDER HEAD SCREW M3 x 6 B-NI | 2 | M2-000-391 |

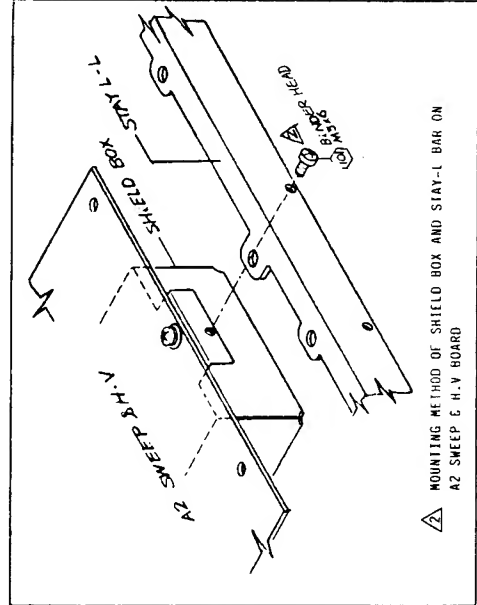
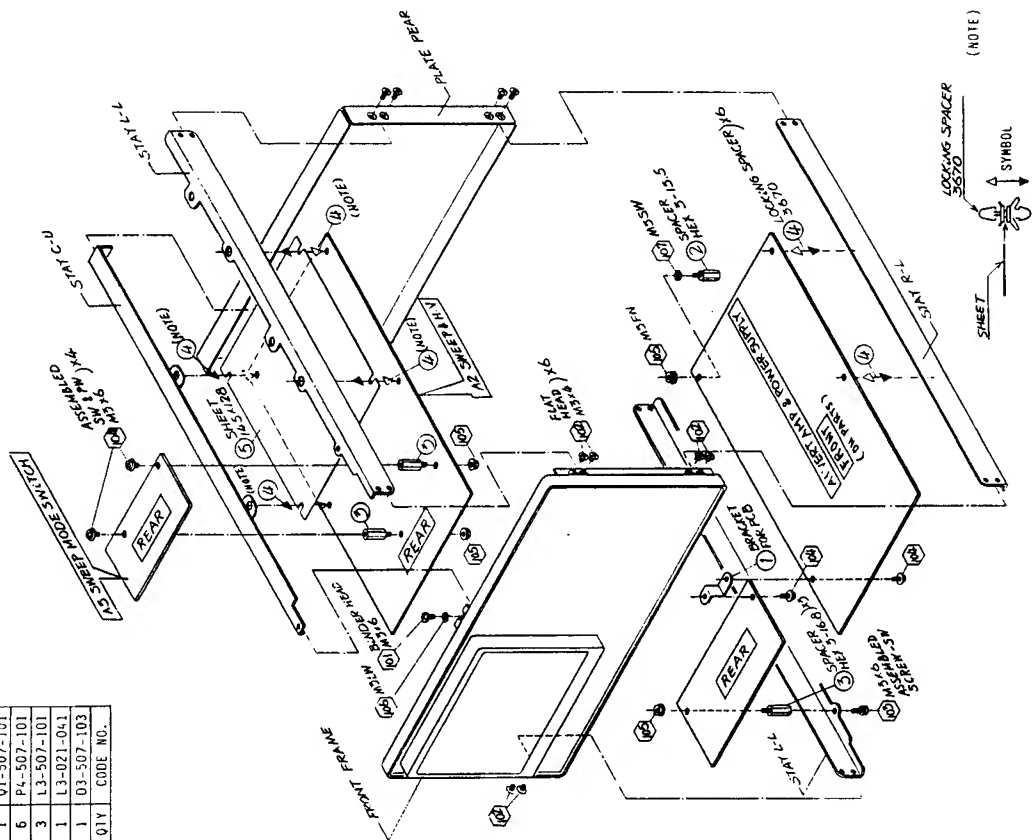

▲ MOUNTING METHOD OF SHIELD BOX AND STAY-L BAR ON A2 SWEEP & H.V. BOARD

(NOTE) SHEET INSERTION METHOD:
Insert slit of sheet into gap at waist of locking spacer.

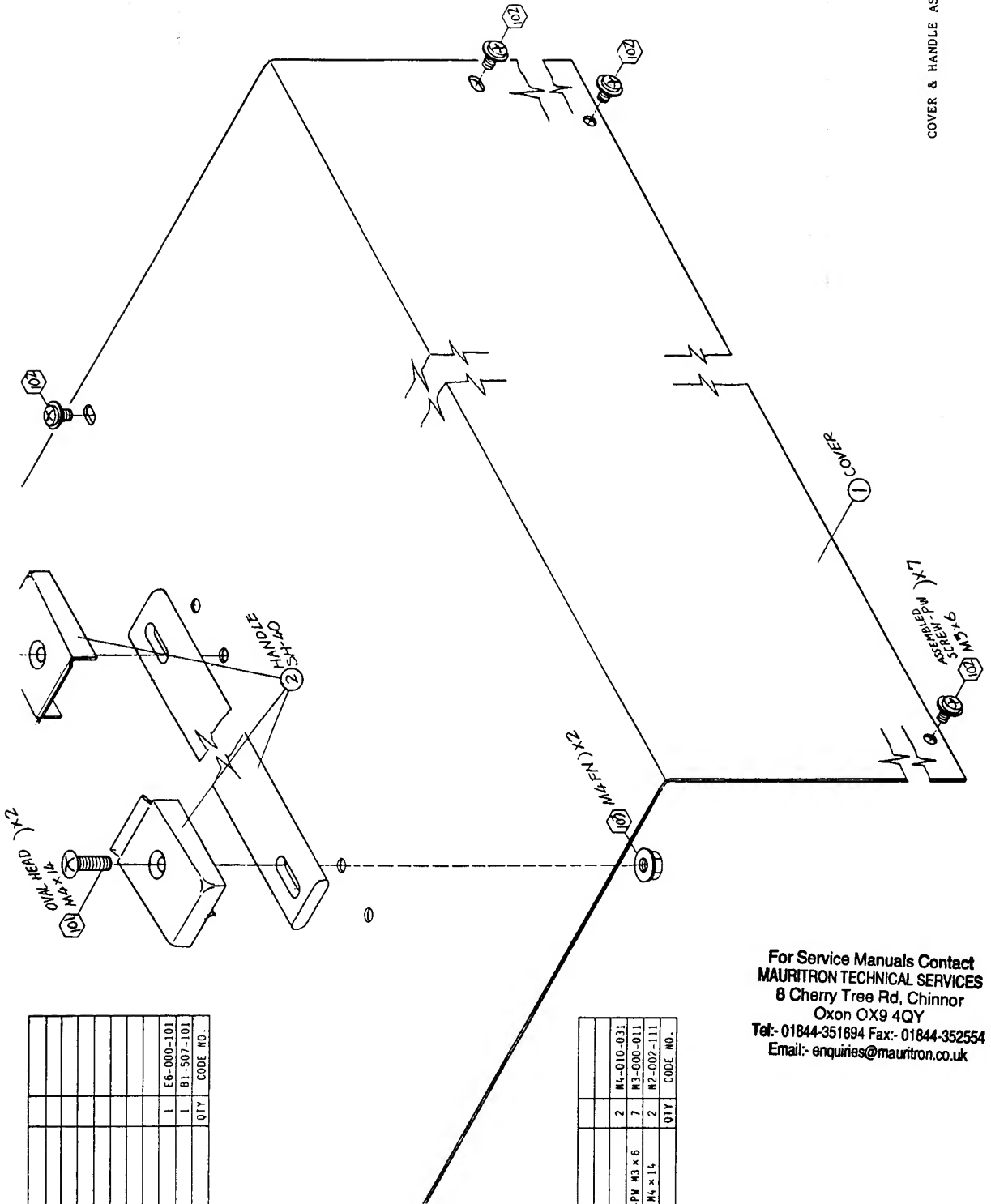

| NO. | NAME | QTY | CODE NO. |
|-----|--------------|-----|------------|
| 10 | | | |
| 9 | | | |
| 8 | | | |
| 7 | | | |
| 6 | | | |
| 5 | | | |
| 4 | | | |
| 3 | HANDLE SH-40 | 1 | E6-000-101 |
| 2 | COVER | 1 | B1-507-101 |
| 1 | | | |

| NO. | NAME | QTY | CODE NO. |
|-----|---------------------------|-----|------------|
| 105 | | | |
| 104 | | | |
| 103 | FLANGE NUT M4FN | 2 | M4-010-031 |
| 102 | ASSEMBLED SCREW-PW M3 x 6 | 7 | M3-000-011 |
| 101 | OVAL HEAD SCREW M4 x 16 | 2 | M2-002-111 |
| | | | |

For Service Manuals Contact
MAURITRON TECHNICAL SERVICES
 8 Cherry Tree Rd, Chinnor
 Oxon OX9 4QY
 Tel:- 01844-351694 Fax:- 01844-352554
 Email:- enquiries@mauritron.co.uk

| NO. | NAME | QTY | CODE NO. |
|-----|-----------------|-----|------------|
| 10 | | | |
| 9 | | | |
| 8 | | | |
| 7 | | | |
| 6 | | | |
| 5 | | | |
| 4 | STAND BRACKET | 2 | P2-050-141 |
| 3 | FOOT 20-17 | 2 | P2-000-381 |
| 2 | STAND 202 x 100 | 1 | E7-507-101 |
| 1 | BOTTOM PLATE | 1 | B6-507-101 |
| QTY | NAME | QTY | CODE NO. |

| NO. | NAME | QTY | CODE NO. |
|-----|------------------------------|-----|------------|
| 110 | | | |
| 109 | | | |
| 108 | | | |
| 107 | | | |
| 106 | | | |
| 105 | FLANGE NUT M4FN | 2 | M4-010-031 |
| 104 | FLANGE NUT M3FN | 2 | M4-010-021 |
| 103 | ASSEMBLED SCREW-SMCPW M4x14 | 2 | M3-012-101 |
| 102 | ASSEMBLED SCREW-PW M3x6 B-WT | 2 | M3-000-011 |
| 101 | FLAT HEAD SCREW M3x16 | 2 | M2-001-391 |
| NO. | NAME | QTY | CODE NO. |

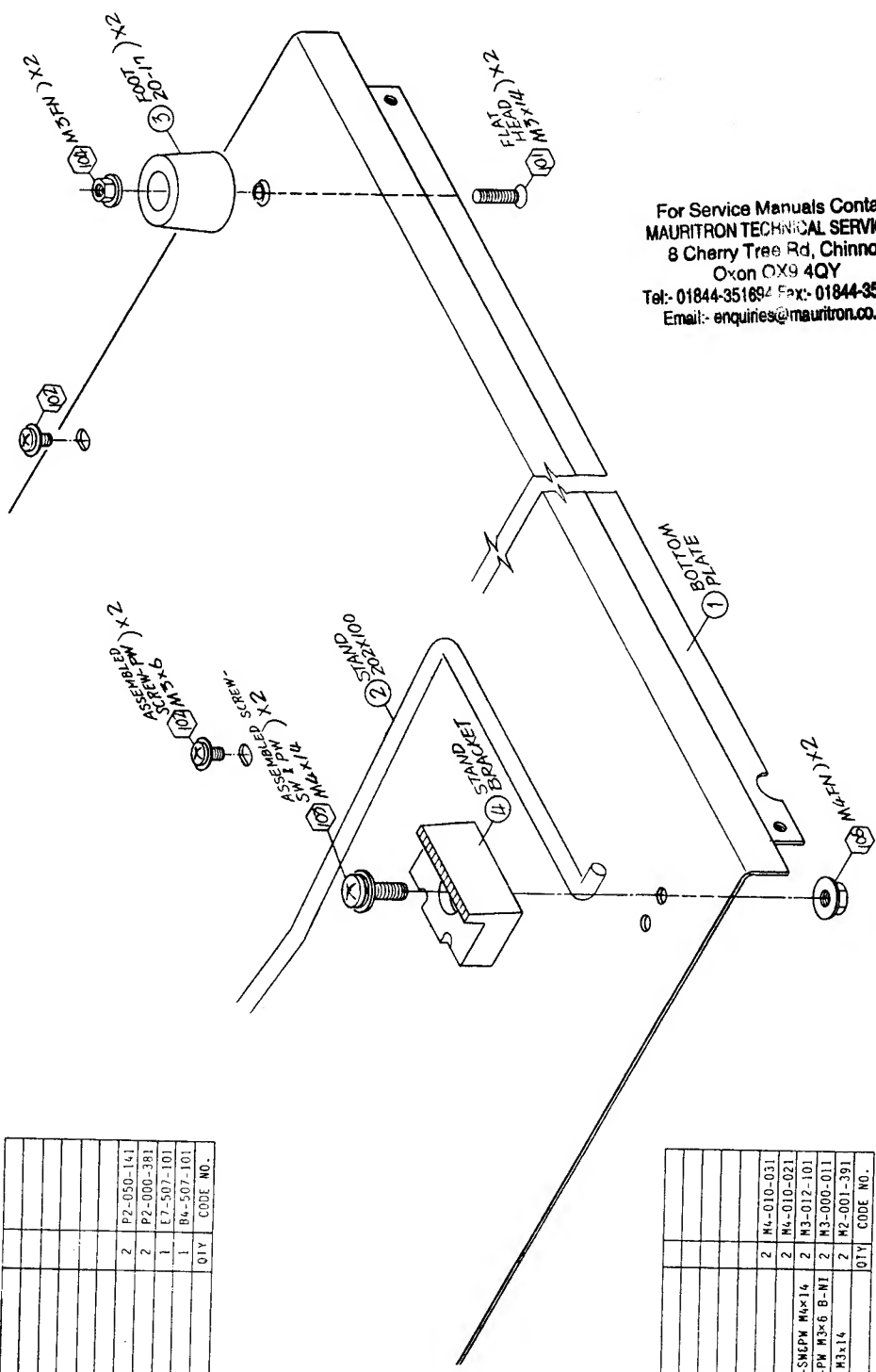

For Service Manuals Contact
MAURITRON TECHNICAL SERVICES
 8 Cherry Tree Rd, Chinnor
 Oxon OX9 4QY
 Tel:- 01844-351694 Fax:- 01844-352554
 Email:- enquiries@mauritron.co.uk